

NEW HYBRID INTELLIGENT APPROACH TO FORECAST WIND POWER AND ELECTRICITY PRICES IN THE SHORT-TERM

J.P.S. Catalão
UBI and CIEEE-IST
Portugal
catalao@ubi.pt

H.M.I. Pousinho
UBI and CIEEE-IST
Portugal
hmi-21@hotmail.com

V.M.F. Mendes
ISEL
Portugal
vfmendes@isel.pt

Abstract – The increased integration of wind power into the grid poses challenges due to its intermittency. Besides, deregulation of the energy markets brings electricity prices uncertainty. Hence, a new hybrid intelligent approach is proposed in this paper to forecast wind power and electricity prices in the short-term. Results from real-world case studies are presented, in order to illustrate the proficiency of the proposed approach. Finally, conclusions are duly drawn.

Keywords: *Computational intelligence, Forecasting, Wind energy, Pricing, Simulation*

1 INTRODUCTION

Wind energy is gaining increasing importance throughout the world [1], and wind-driven power resources have become increasingly important in the planning and operations of power systems. In Portugal, the wind power goal foreseen for 2012 was established by the government as 5100 MW. Hence, Portugal has one of the most ambitious goals in terms of wind power.

Wind-generated electric energy is accepted as it comes, i.e. as it is available. However, the availability of the power supply generated from wind energy is not known in advance. The integration of massive intermittent wind power generation leads to some important challenges. Unlike hydro or thermal systems [2], which are traditional dispatchable power sources, wind power is undispachable [3] and constitutes a major source of uncertainty in the planning and operations of power systems. In this context, wind power forecasting plays a key role in tackling those challenges [4].

All over the world, the electricity industry is converging toward a competitive framework and a market environment is replacing the traditional monopolistic scenery for the electricity industry. Deregulation brings electricity prices uncertainty, placing higher requirements on forecasting.

In most competitive energy markets the series of prices presents the following features: high frequency, non-constant mean and variance, daily and weekly seasonality, calendar effect on weekend and public holidays, high volatility and high percent-age of unusual prices [5]. Hence, price forecasting is extremely important for all market participants for their survival under competitive environment [6]. An accurate forecast of electricity prices is a very important tool for a generating company to optimally schedule its power resources and to develop appropriate bidding strategies in the market.

In the technical literature, several methods to forecast wind power have been reported, namely physical and statistical methods. Physical method has advantages in long-term prediction while statistical method does well in short-term prediction [7].

Similarly, several techniques to forecast short-term electricity prices have been reported, namely hard and soft computing techniques. Artificial intelligence approaches can be much more efficient computationally and as accurate as time series models, if the correct inputs are considered [8].

In this paper, a hybrid intelligent approach combining wavelet transform (WT), particle swarm optimization (PSO) and adaptive-network-based fuzzy inference system (ANFIS) is proposed to forecast wind power production and electricity prices in the short-term.

We report our experience with the implementation of this new approach on two realistic case studies. Significant improvements are clearly shown taking into account other methodologies currently applied in the power system domain. Finally, conclusions are duly drawn.

2 PROPOSED APPROACH

The proposed approach is based on the combination of WT, PSO and ANFIS. The WT is used to decompose the wind-price series into a set of constitutive series. Then, the future values of these constitutive series are forecasted using ANFIS. The PSO is used to improve the performance of ANFIS, tuning the membership functions required to achieve a lower error. Finally, the ANFIS forecasts allow, through the inverse WT, reconstructing the future behavior of the wind-price series and therefore to forecast wind power and electricity prices.

2.1 Wavelet Transform

As mentioned previously, the WT convert a wind-price series into a set of constitutive series. These constitutive series present a better behavior than the original series, and therefore, they can be predicted more accurately. The reason for the better behavior of the constitutive series is the filtering effect of the WT. Background on WT can be found, for instance, in [9].

A wavelet function of type Daubechies of order 4 is used as the mother wavelet. This wavelet offers an appropriate trade-off between wave-length and smoothness. Also, three decomposition levels are considered, as shown in Figure 1.

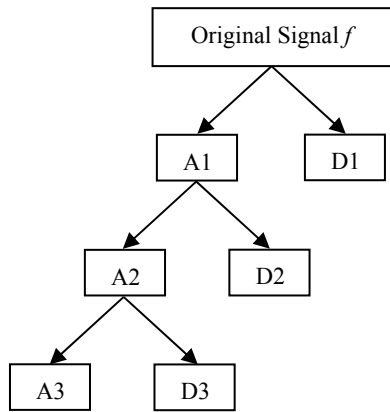

Figure 1: Multilevel decomposition process.

2.2 Particle Swarm Optimization

PSO is a heuristic approach first proposed by Kennedy and Eberhart as an evolutionary computational method. The PSO algorithm is based on the biological and sociological behavior of animals searching for their food. Background on PSO can be found, for instance, in [10]. Figure 2 illustrates the search mechanism of a PSO technique, where x denote a particle's position and v denote the particle's flight velocity over a solution space. The best previous position of a particle is P_{best} . The index of the best particle among all particles in the swarm is G_{best} .

2.3 ANFIS

ANFIS is a class of adaptive multi-layer feedforward networks, applied to nonlinear forecasting where past samples are used to forecast the sample ahead. ANFIS incorporates the self-learning ability of NN with the linguistic expression function of fuzzy inference. Background on ANFIS can be found, for instance, in [8].

The ANFIS architecture is shown in Figure 3, which is composed of five layers. Each layer contains several nodes described by the node function.

In this paper, ANFIS employs PSO method to adjust the parameters of the membership functions, as in [11]. The membership functions considered in this study are triangular-shaped.

2.4 Hybrid Approach

In this section, the algorithm used to implement the proposed approach is described step-by-step.

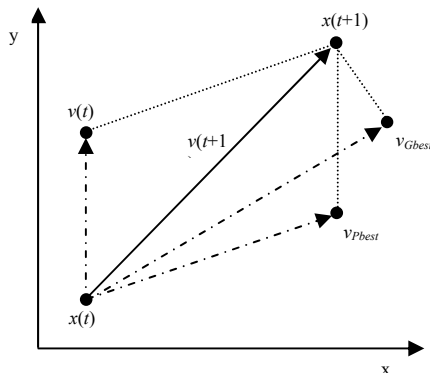

Figure 2: Updating the position mechanism of PSO.

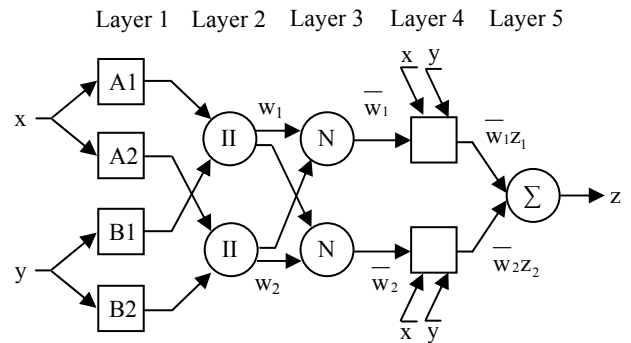

Figure 3: ANFIS architecture.

As depicted in Figure 4, wavelet techniques are implemented in the first and last stages. The actual time-series (wind power and electricity price data) are first decomposed into a number of wavelet coefficient signals and one approximation signal. The decomposed signals are then fed into the ANFIS at the second stage to predict the future time-series patterns for each of the signals. Finally, the predicted signals are recombined in the last stage to form the final predicted series.

- *First step:* Form a matrix with a set of historical data, arranged in C columns of a matrix thereof. Each column of the array has an associated profile.

- *Second step:* Select a number of columns of the previous array so that the set of values derived from it represents the real input data. In this step, appropriate inputs are selected based on a correlation analysis.

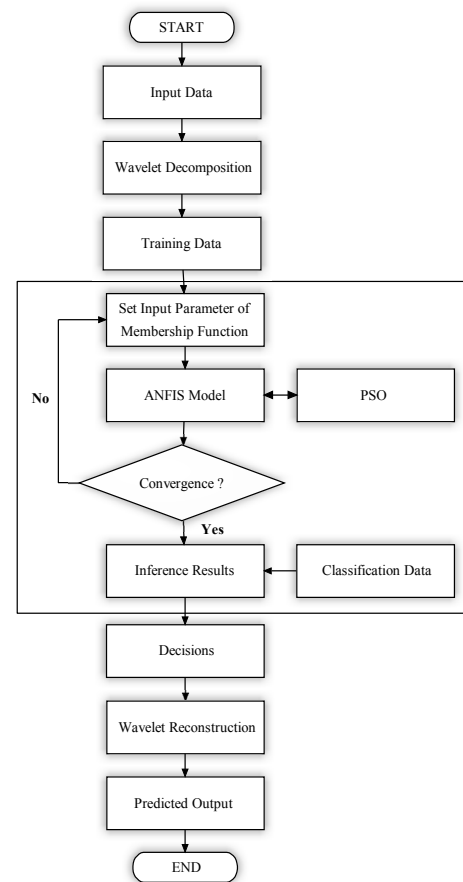

Figure 4: Flowchart of the proposed approach.

- *Third step*: Decompose the input data using WT. The operation mode of this process is to decompose the vector with the input data selected. The signal is divided into three levels, namely, a level of approximation (A) and details (D). The wavelet function used is the Db4 type, which offers a good approach and ability to use a relatively small number of coefficients, making the code faster.

- *Fourth step*: Get the signal from the Wavelet reorganized so that it can be submitted to the entrance of the ANFIS structure.

- *Fifth step*: Train the ANFIS with the data from the implementation of the previous step. The ANFIS uses a combination of the least-squares method and the back-propagation gradient descent method. The training process allows the system to adjust its parameters as inputs/outputs submitted. The PSO is used to train the parameters associated with the membership functions of fuzzy inference system.

- *Sixth step*: Create a vector with N -dimension, where N equals the number of membership functions. This vector contains the parameters of membership function and will be optimized by PSO algorithm. The fitness function is defined as the mean squared error.

- *Seventh step*: Define the parameters associated with the PSO algorithm (Table 1). Parameters are initialized randomly in first stage and then are being updated using PSO algorithm.

- *Eighth step*: Extract the output of the ANFIS using the parameters found by the PSO.

- *Ninth step*: Use wavelet again to reconstruct the wind-price series forecast given by ANFIS. The final output corresponds to the predictions of our hybrid intelligent approach.

3 FORECASTING ACCURACY EVALUATION

To evaluate the accuracy in forecasting wind power and electricity prices, the mean absolute percentage error (MAPE) is considered.

The MAPE criterion is defined as follows:

$$MAPE = \frac{100}{N} \sum_{h=1}^N \frac{|\hat{p}_h - p_h|}{p} \quad (1)$$

$$\bar{p} = \frac{1}{N} \sum_{h=1}^N p_h \quad (2)$$

Parameters	Value
Number of Particles	25
Number of Iterations	2000
Cognitive Acceleration	2.0
Social Acceleration	2.0
Initial Inertia Weight	0.9
Final Inertia Weight	0.4

Table 1: Parameters of PSO.

In (1) and (2), \hat{p}_h and p_h are respectively the forecasted and actual values at period h , \bar{p} is the average value of the forecasting period, and N is the number of forecasted periods. For wind power forecasting N is considered equal to 24, while for electricity prices forecasting N is considered equal to 168.

A measure of the uncertainty of a model is the variability of what is still unexplained after fitting the model, which can be measured through the estimation of the variance of the error. The smaller this variance, the more precise is the prediction [12]. Consistent with definition (1), error variance can be estimated as:

$$\sigma_e^2 = \frac{1}{N} \sum_{h=1}^N \left(\frac{|\hat{p}_h - p_h|}{\bar{p}} - e \right)^2 \quad (3)$$

$$e = \frac{1}{N} \sum_{h=1}^N \frac{|\hat{p}_h - p_h|}{\bar{p}} \quad (4)$$

The MAPE and error variance are used in this paper.

4 CASE STUDIES

The proposed hybrid intelligent approach has been applied for the prediction of the wind power in Portugal the next 24 hours. The numerical results presented take into account the wind farms that have telemetry with the National Electric Grid (REN). The wind power profile in Portugal at January 2008 is shown in Figure 5.

Also, our approach has been applied to forecast next-week (168 hours) prices in the electricity market of mainland Spain. It should be noted that the Spanish market is a duopoly with a dominant player, resulting in price changes related to the strategic behavior of the dominant player, which are hard to predict. The daily average price in the Spanish market at 2002 is shown in Figure 6.

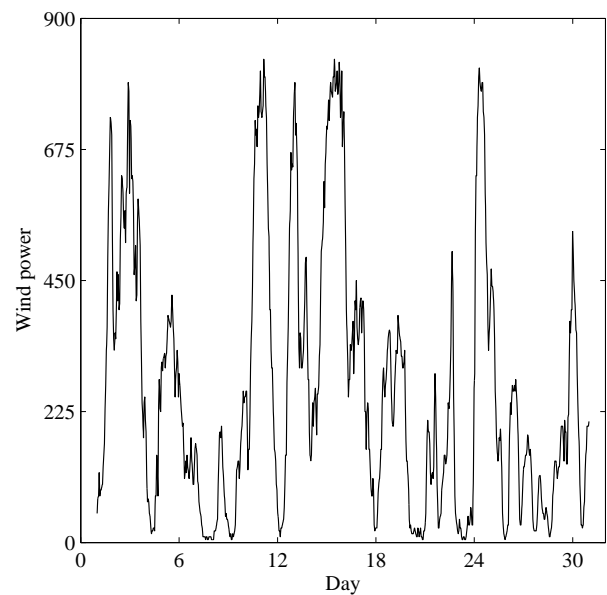

Figure 5: Wind power profile in Portugal at January 2008, in megawatt.

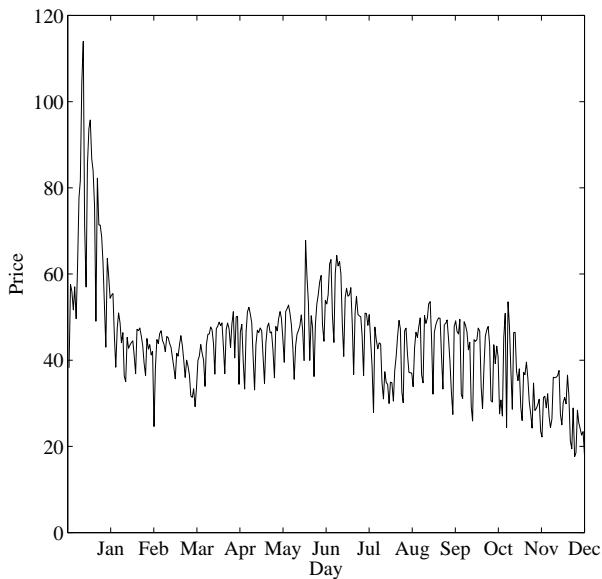

Figure 6: Daily average price in the electricity market of mainland Spain at 2002, in euro per megawatt hour.

4.1 Short-Term Wind Power Forecasting

Historical wind power data are the only inputs for training the ANFIS. Hence, for the sake of clear comparison, no exogenous variables are considered.

Our forecaster predicts the value of the wind power subseries for 3 hours ahead, taking into account the wind power data of the previous 12 hours with a time-step of 15 minutes (the first 36 values are used for training, while the last 12 values are used for testing). The following days are randomly selected: July 3, 2007, October 31, 2007, January 14, 2008, and April 2, 2008, corresponding to the four seasons of the year.

Numerical results with the hybrid intelligent approach are shown in Figures 7 to 10 respectively for the winter, spring, summer and fall days.

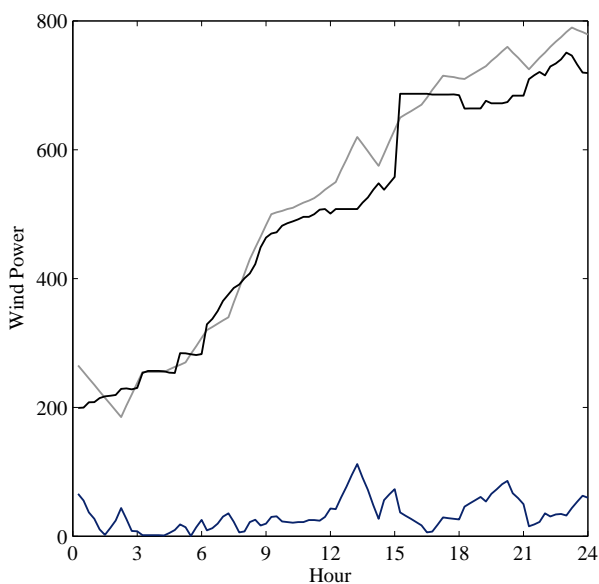

Figure 7: Winter day: actual wind power, gray line, together with the forecasted wind power, black line, in megawatt; absolute value of forecast errors, blue line at the bottom.

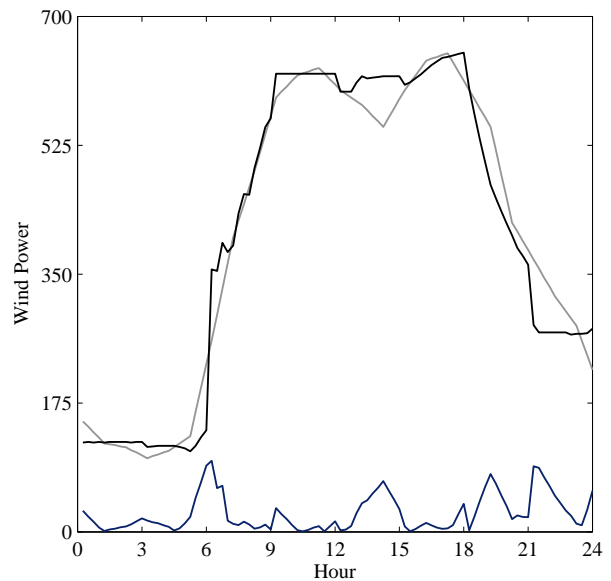

Figure 8: Spring day: actual wind power, gray line, together with the forecasted wind power, black line, in megawatt; absolute value of forecast errors, blue line at the bottom.

Table 2 shows a comparison (MAPE criterion) between the hybrid intelligent approach (WPA) and four other approaches: persistence, auto regressive integrated moving average (ARIMA), neural networks (NN) [13], and NN in combination with wavelet transform (WT), NNWT [14].

The proposed approach presents better forecasting accuracy: the MAPE has an average value of 4.98%. Improvement in the average MAPE of the proposed approach with respect to the four previous approaches is 73.9%, 51.8%, 31.4% and 28.6%, respectively.

In addition to MAPE, stability of results is another important factor for the comparison of forecast approaches.

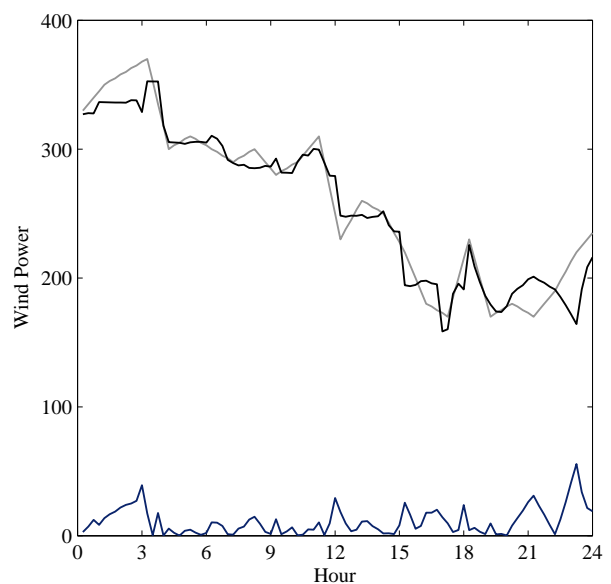

Figure 9: Summer day: actual wind power, gray line, together with the forecasted wind power, black line, in megawatt; absolute value of forecast errors, blue line at the bottom.

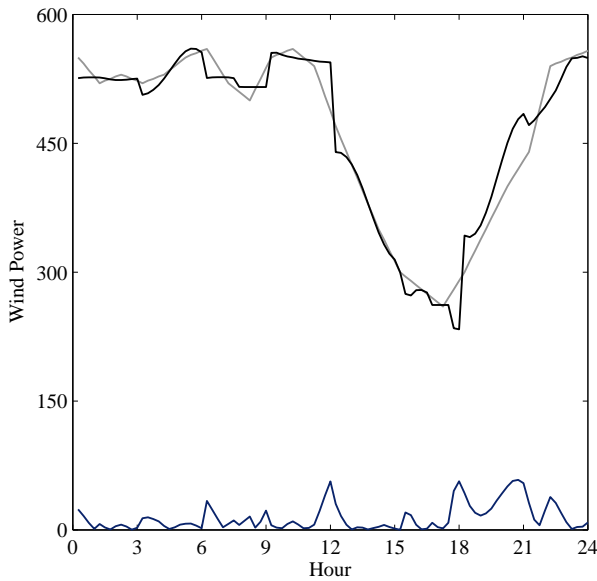

Figure 10: Fall day: actual wind power, gray line, together with the forecasted wind power, black line, in megawatt; absolute value of forecast errors, blue line at the bottom.

Table 3 shows a comparison between the hybrid intelligent approach and the four other approaches, regarding daily error variance.

The average error variance is smaller for the hybrid intelligent approach, indicating less uncertainty in the predictions. Improvement in the average error variance of the proposed approach with respect to the four previous approaches is 91.0%, 73.8%, 58.8% and 55.3%, respectively.

The proposed approach is both novel and effective for short-term prediction of wind power, implying smaller errors.

	Winter	Spring	Summer	Fall
Persistence	13.89	32.40	13.43	16.49
ARIMA	10.93	12.05	11.04	7.35
NN	9.51	9.92	6.34	3.26
NNWT	9.23	9.55	5.97	3.14
WPA	6.47	6.08	4.31	3.07

Table 2: Comparative MAPE results for wind power forecasting.

	Winter	Spring	Summer	Fall
Persistence	0.0074	0.0592	0.0085	0.0179
ARIMA	0.0025	0.0164	0.0090	0.0039
NN	0.0044	0.0106	0.0043	0.0010
NNWT	0.0055	0.0083	0.0038	0.0012
WPA	0.0021	0.0035	0.0016	0.0011

Table 3: Daily forecasting error variance.

4.2 Short-Term Electricity Prices Forecasting

Historical price data are the only inputs for training the ANFIS. Hence, for the sake of clear comparison, no exogenous variables are considered.

For the proposed price forecasting model, 168-h ahead predictions are computed taking into account the hourly historical price data of the previous 42 days (35 and 7 days data used for training and testing, respectively). The same test weeks as in [12], [15]-[18] are selected, corresponding to the four seasons of year 2002.

Numerical results with the hybrid intelligent approach are shown in Figures 11 to 14 respectively for the winter, spring, summer and fall weeks.

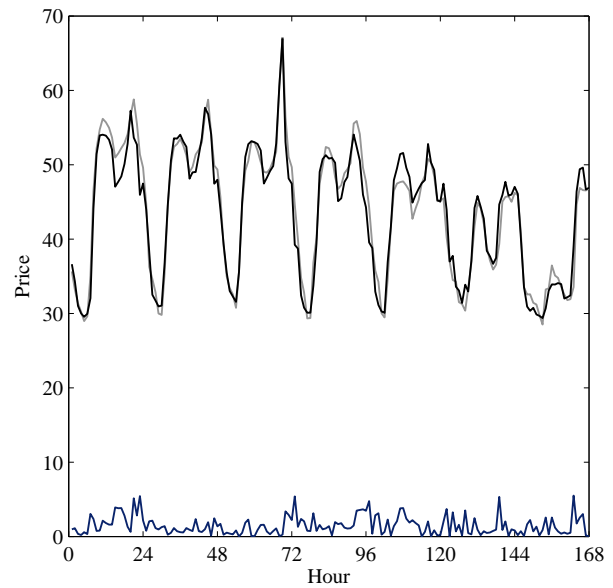

Figure 11: Winter week: actual prices, gray line, together with the forecasted prices, black line, in euro per megawatt hour, and absolute value of forecast errors, blue line.

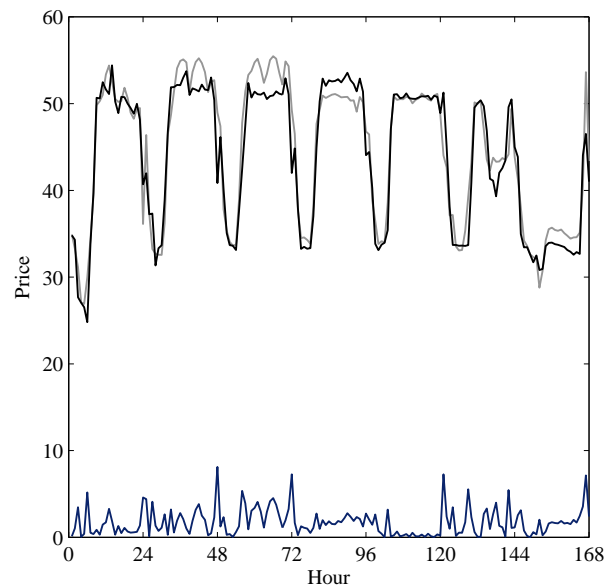

Figure 12: Spring week: actual prices, gray line, together with the forecasted prices, black line, in euro per megawatt hour, and absolute value of forecast errors, blue line.

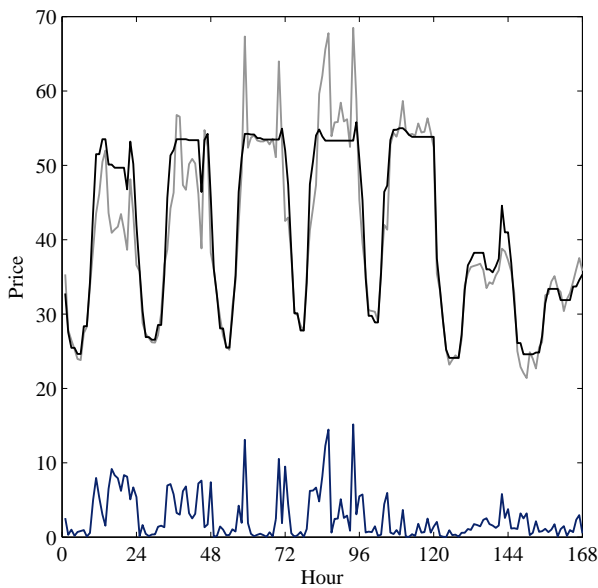

Figure 13: Summer week: actual prices, gray line, together with the forecasted prices, black line, in euro per megawatt hour, and absolute value of forecast errors, blue line.

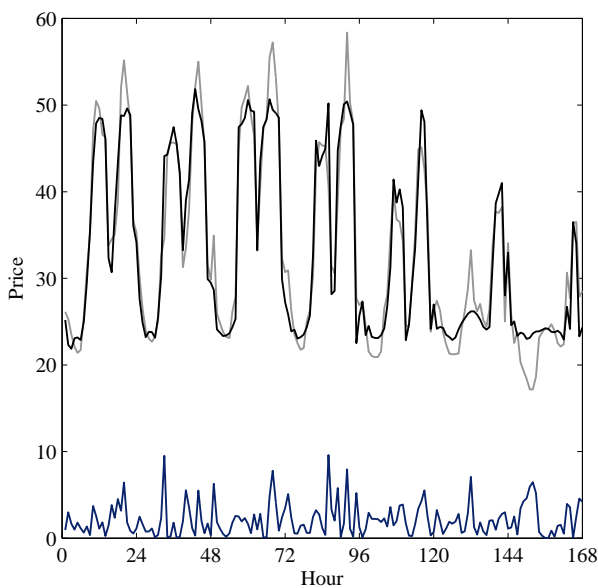

Figure 14: Fall week: actual prices, gray line, together with the forecasted prices, black line, in euro per megawatt hour, and absolute value of forecast errors, blue line at the bottom.

Table 4 shows a comparison (MAPE criterion) between the hybrid intelligent approach (WPA) and five other approaches: wavelet-ARIMA [12], fuzzy neural networks (FNN) [15], adaptive wavelet neural network (AWNN) [16], NNWT [17] and cascaded neuro-evolutionary algorithm (CNEA) [18].

The proposed approach presents better forecasting accuracy: the MAPE has an average value of 5.07%. Improvement in the average MAPE of the proposed approach with respect to the five previous approaches is 37.5%, 32.6%, 24.9%, 23.8% and 4.7%, respectively.

Besides MAPE, stability of results is another important factor for the comparison of forecast approaches.

Table 5 shows a comparison between the hybrid intelligent approach and the five other approaches, regarding weekly error variance.

The average error variance is smaller for the hybrid intelligent approach, indicating less uncertainty in the predictions. Improvement in the average error variance of the proposed approach with respect to the five previous approaches is 57.8%, 50.0%, 43.8%, 27.0% and 25.0%, respectively.

The proposed approach is both novel and effective for short-term prediction of electricity prices, implying smaller errors.

	Winter	Spring	Summer	Fall
Wavelet-ARIMA	4.78	5.69	10.70	11.27
FNN	4.62	5.30	9.84	10.32
AWNN	3.43	4.67	9.64	9.29
NNWT	3.61	4.22	9.50	9.28
CNEA	4.88	4.65	5.79	5.96
WPA	3.37	3.91	6.50	6.51

Table 4: Comparative MAPE results for electricity prices forecasting.

	Winter	Spring	Summer	Fall
Wavelet-ARIMA	0.0019	0.0025	0.0108	0.0103
FNN	0.0018	0.0019	0.0092	0.0088
AWNN	0.0012	0.0031	0.0074	0.0075
NNWT	0.0009	0.0017	0.0074	0.0049
CNEA	0.0036	0.0027	0.0043	0.0039
WPA	0.0008	0.0013	0.0056	0.0033

Table 5: Weekly forecasting error variance.

4.3 Computational Burden

The average computation time required by the hybrid intelligent approach is less than 1 minute using MATLAB on a PC with 1 GB of RAM and a 2.0-GHz-based processor. Hence, the proposed approach presents not only better forecasting accuracy, but also an acceptable computation time.

5 CONCLUSION

A new hybrid intelligent approach is proposed in this paper to forecast wind power and electricity prices in the short-term. The proposed approach outperforms four other approaches, regarding wind power forecasting, and outperforms five other approaches, regarding electricity prices forecasting, while the average computation time is acceptable. Hence, the presented results validate the proficiency of the proposed approach, representing a novel and effective tool in short-term forecasting.

ACKNOWLEDGMENT

This work is funded by FEDER funds (European Union) through the Operational Programme for Competitiveness Factors – COMPETE, and by Portuguese funds through the Fundação para a Ciência e a Tecnologia – FCT, under Project No. FCOMP-01-0124-FEDER-014887 (Ref. FCT PTDC/EEA-EEL/110102/2009). Also, H.M.I. Pousinho thanks FCT for a Ph.D. grant (SFRH/BD/62965/2009).

REFERENCES

- [1] T. Ackermann, “Wind Power in Power Systems”, West Sussex, John Wiley and Sons Ltd., 2005
- [2] J. P. S. Catalão, S. J. P. S. Mariano, V. M. F. Mendes and L.A.F.M. Ferreira, “Influence of Price Forecasting on Short-Term Thermal Scheduling with Environmental Concerns”, 16th PSCC Proceedings, July 2008
- [3] A. Borghetti et al, “Short-Term Scheduling and Control of Active Distribution Systems with High Penetration of Renewable Resources”, IEEE Systems Journal, Vol. 4, No. 3, pp 313-322, September 2010
- [4] B. Ernst et al, “Predicting the Wind”, IEEE Power & Energy Magazine, Vol. 5, No. 6, pp 78-89, November-December 2007
- [5] A. Muñoz et al, “Short-Term Forecasting in Power Systems: A Guide Tour”, in Handbook of Power Systems II, Springer Berlin, pp 129-160, 2010
- [6] S. K. Aggarwal, L. M. Saini and A. Kumar, “Electricity Price Forecasting in Deregulated Markets: A Review and Evaluation”, International Journal of Electrical Power & Energy Systems, Vol. 31, No. 1, pp 13-22, January 2009
- [7] L. Ma, S. Y. Luan, C. W. Jiang, H. L. Liu and Y. Zhang, “A Review on the Forecasting of Wind Speed and Generated Power”, Renewable & Sustainable Energy Reviews, Vol. 13, No. 4, pp 915-920, May 2009
- [8] C. P. Rodriguez and G. J. Anders, “Energy Price Forecasting in the Ontario Competitive Power System Market”, IEEE Transactions on Power Systems, Vol. 19, No. 1, pp 366-374, February 2004
- [9] N. Amjady and F. Keynia, “Short-term Load Forecasting of Power Systems by Combination of Wavelet Transform and Neuro-Evolutionary Algorithm”, Energy, Vol. 34, No. 1, pp 46-57, January 2009
- [10] Z. A. Bashir and M. E. El-Hawary, “Applying Wavelets to Short-Term Load Forecasting using PSO-based Neural Networks”, IEEE Transactions on Power Systems, Vol. 24, No. 1, pp 20-27, February 2009
- [11] M. A. Shoorehdeli, M. Teshnehlab, A. K. Sedigh and M. A. Khanesar, “Identification using ANFIS with Intelligent Hybrid Stable Learning Algorithm Approaches and Stability Analysis of Training Methods”, Applied Soft Computing, Vol. 9, No. 2, pp 833-850, March 2009
- [12] A. J. Conejo, M. A. Plazas, R. Espínola and A. B. Molina, “Day-Ahead Electricity Price Forecasting using the Wavelet Transform and ARIMA Models”, IEEE Transactions on Power Systems, Vol. 20, No. 2, pp 1035-1042, May 2005
- [13] J. P. S. Catalão, H. M. I. Pousinho and V. M. F. Mendes, “An Artificial Neural Network Approach for Short-Term Wind Power Forecasting in Portugal”, Engineering Intelligent Systems for Electrical Engineering and Communications, Vol. 17, No. 1, pp 5-11, March 2009
- [14] J. P. S. Catalão, H. M. I. Pousinho and V. M. F. Mendes, “Short-Term Wind Power Forecasting in Portugal by Neural Networks and Wavelet Transform”, Renewable Energy, Vol. 36, No. 4, pp 1245-1251, April 2011
- [15] N. Amjady, “Day-Ahead Price Forecasting of Electricity Markets by a New Fuzzy Neural Network”, IEEE Transaction on Power Systems, Vol. 21, No. 2, pp 887-896, May 2006
- [16] N. M. Pindoriya, S. N. Singh and S. K. Singh, “An Adaptive Wavelet Neural Network-based Energy Price Forecasting in Electricity Markets”, IEEE Transactions on Power Systems, Vol. 23, No. 3, pp 1423-1432, August 2008
- [17] J. P. S. Catalão, H. M. I. Pousinho and V. M. F. Mendes, “Neural Networks and Wavelet Transform for Short-Term Electricity Prices Forecasting”, Engineering Intelligent Systems for Electrical Engineering and Communications, Vol. 18, No. 2, pp 85-92, June 2010
- [18] N. Amjady and F. Keynia, “Day-Ahead Price Forecasting of Electricity Markets by Mutual Information Technique and Cascaded Neuro-Evolutionary Algorithm”, IEEE Transactions on Power Systems, Vol. 24, No. 1, pp 306-318, February 2009