

COUPLING OPF AND TOPOLOGY OPTIMIZATION FOR SECURITY PURPOSES

Fabrice Zaoui Stéphane Fliscounakis Robert Gonzalez
Réseau de Transport d'Electricité (French TSO)
9 rue de la porte de Buc, BP 561, 78005 VERSAILLES, FRANCE
fabrice.zaoui@rte-france.com

Abstract – The paper presents the association of a DC OPF tool with the modeling of topological network states in terms of a linear integer programming optimization process for the N-k static state security. The proposed model is for the help of real-time network operators to ensure the security of the power system more efficiently.

Keywords: *Mixed Integer Linear Programming (MILP), OPF and associated optimal topology*

1 INTRODUCTION

The monitoring of the electrical power system is more and more crucial. While the competitive market permits the playing of various and numerous actors, the TSO still has to ensure a non-discriminative network access with a high level of security.

Planning studies help the power transmission network operator to forecast necessary investments to reach the equilibrium between the expectative load and the predictable supply. The transmission problems deal with mid or long term period, typically the forthcoming years. For shortest periods going from real-time observations to the management of next days, the operator has to deal with the security of transmission in a strongly constrained environment.

The growth of MILP applications is important for the last years in the community of the electrical power research. Many works concern the difficult congestion management problem in terms of generation scheduling or network expansion planning. The used optimization methods to solve this problem are based on decomposition techniques [1-5], heuristics [6-9] or direct approaches [10][11]. For the topology management in terms of mixed integer linear optimization, one can note recent works of interest concerning the static state estimation [12].

This paper is for the help of dispatching operators in everyday life management of the power transmission network. It proposes to deal with the N-k security problem by simultaneously acting on MW power re-dispatching and network topology configurations. The problem is modeled as a mixed integer linear program where the objective is to minimize the deviations of the defined generations and of the topology configuration. OPF is treated as a DC problem and topology modifications are expressed with mixed integer inequalities [13]. Problems are solved using a Branch and Bound algorithm [14] developed at RTE.

2 TOPOLOGY MANAGEMENT

The topology is modeled in a nodal scheme. Three types of problem are considered.

2.1 Disconnection of a Circuit

The disconnection is modeled with a Boolean variable t_{ij} and four inequalities defining the flow T_{ij} in the circuit (ij) [10].

$$\begin{cases} (t_{ij} - 1)\bar{T}_{ij} \leq T_{ij} \\ (1 - t_{ij})\bar{T}_{ij} \geq T_{ij} \end{cases} \quad (\text{E.1})$$

where:

- T_{ij} is the active power flow in the circuit (ij);
- \bar{T}_{ij} is the maximum value of the active power flow in the circuit (ij);
- t_{ij} is a Boolean variable indicating the presence of the circuit (ij).

$$\begin{cases} -\frac{M_{ij}}{X_{ij}}t_{ij} \leq T_{ij} - U^2 \frac{(\theta_i - \theta_j)}{X_{ij}} \\ \frac{M_{ij}}{X_{ij}}t_{ij} \geq T_{ij} - U^2 \frac{(\theta_i - \theta_j)}{X_{ij}} \end{cases} \quad (\text{E.2})$$

where:

- θ_i is the voltage angle at bus i ;
- U is the nominal voltage;
- X_{ij} is the reactance of the circuit connecting the buses i and j ;
- M_{ij} is a penalty parameter for the circuit (ij).

Equation (E.1) enforces the active power flow of a connected circuit ($t_{ij} = 0$) into its validation domain. If the circuit is disconnected ($t_{ij} = 1$), Equation (E.1) ensures that no flow will go through the circuit (ij). Equation (E.2) gives the definition of the active power T_{ij} in case of a connection. It also frees the phase difference in case of a disconnection by the use of a penalty parameter.

Most MILP solvers include a scaling phase. This phase is strongly recommended to improve the numerical characteristics of the LP problem and thus to avoid

instabilities due to ill conditioning [15]. It is generally said that a matrix is well scaled if the magnitudes of its nonzero elements are close to each other. In this context, the choice of the penalty parameter M_{ij} is of a particular interest. This value must not be huge and must not be small to define a range including the optimal solution for the phase difference. A proposal for a good initialization of M_{ij} can be found in [10].

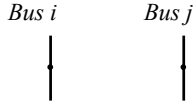

Figure 1: The circuit (ij) is disconnected: $t_{ij} = 1$.

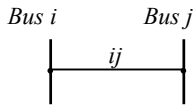

Figure 2: The circuit (ij) is connected: $t_{ij} = 0$.

2.2 Multiple Connections of a Circuit

The connection of a circuit can be multiple (Figure 3). In this case the origin i of the circuit (ij) does not change. It is the extremity j that can be connected to various buses.

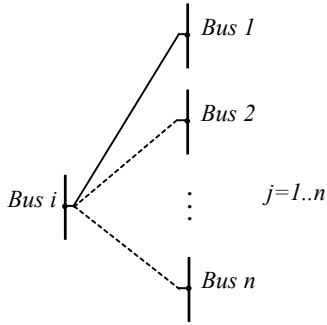

Figure 3: Possible connections of bus i .

With the help of the previous inequalities (E.1) and (E.2), the unique connection is imposed with the supplementary equation:

$$\sum_{j=1}^n t_{ij} = 1 \quad (\text{E.3})$$

2.3 Buses Merging

To figure the different topologies of a substation in a nodal scheme, it is necessary to introduce the merging and splitting of buses. As previously, this can be easily modeled with linear inequalities.

$$\begin{cases} F_{ij}(f_{ij} - 1) \leq \theta_i - \theta_j \\ F_{ij}(1 - f_{ij}) \geq \theta_i - \theta_j \end{cases} \quad (\text{E.4})$$

where:

- f_{ij} is a Boolean variable indicating the merge or split of buses i and j ;

- F_{ij} is a penalty parameter.

and:

$$-f_{ij}F_{ij}' \leq T_{ij}' \leq f_{ij}F_{ij}' \quad (\text{E.5})$$

where T_{ij}' is an equilibrium flow to balance the power node equation – first Kirchoff's law.

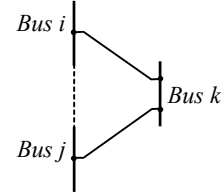

Figure 4: The buses i and j are split: $f_{ij} = 0$.

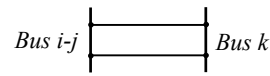

Figure 5: The buses i and j are merged: $f_{ij} = 1$.

If f_{ij} is true, corresponding buses are merged as imposed by the equality of phases (E.4). In this case, T_{ij}' can vary in a large domain (E.5).

If f_{ij} is false, corresponding buses are split and consequently the flow T_{ij}' is equal to zero.

3 OPF CONSIDERATIONS

3.1 General

As the work concerns the problems in the short term, OPF does not manage any generation dispatch. It is supposed that all initial values of power generations are given. They define the set of pre-defined units and the role of the OPF is to change their values only if this is requested by constraints resolution.

3.2 Injections Switching

In addition to these units, OPF can act on special supplementary units for security purposes. These units are either called from scratch or disconnected to assume the security for the base case and with contingencies.

Thus, a supplementary unit is modeled as a switch of active power injection G_i . G_i is equal to zero or included in the range $[G_i^{\min}, G_i^{\max}]$ as modeled below:

$$\forall i \in N, \quad g_i G_i^{\min} \leq G_i \leq g_i G_i^{\max} \quad (\text{E.6})$$

where:

- N is the set of supplementary units;
- g_i is a Boolean variable indicating the presence of the unit i ;
- G_i^{\min} and G_i^{\max} are bounds on the power generation of the unit i .

If necessary, it is also possible to model the load shedding calculation with a binary form since the cut of

a link toward a consumption site is really an “all or nothing” action:

$$D_i = d_i C_i \quad (E.7)$$

where:

- D_i is the calculated active power load shedding at bus i ;
- C_i is the active power consumption value at bus i ;
- d_i is a Boolean variable forcing the load shedding existence to the value of the consumption at bus i .

3.3 Phase Shifting Transformer

A phase shifting transformer is used to control the flow of active power in the transmission network. It introduces a phase angle in order to help alleviate violations on the circuits in the system.

Usually the reactance of the transformer changes with the off nominal turns ratio. For each tap ratio, there is a reactance value corresponding to a phase angle.

Following equations define the active flow through the transformer as a function of the existing tap ratios.

$$\forall l \in \Gamma, \begin{cases} L_{ij}(l-1) \leq T_{ij} - \frac{U^2}{X_{ij}(l)}(\theta_i - \theta_j - \varphi_{ij}(l)) \\ L_{ij}(1-l) \geq T_{ij} - \frac{U^2}{X_{ij}(l)}(\theta_i - \theta_j - \varphi_{ij}(l)) \end{cases} \quad (E.8)$$

where:

- Γ is the set of Boolean variables indicating the existing tap ratios for the transformer (ij) ;
- $card(\Gamma) = N_L$
- N_L is the total number of tap ratios for the transformer (ij) ;
- l is a Boolean variable for a tap ratio and L_{ij} is a penalty parameter for the transformer (ij) ;
- $X_{ij}(l)$ is the reactance of transformer (ij) for the tap ratio pointed by l ;
- $\varphi_{ij}(l)$ is the phase angle introduced by the transformer (ij) for the tap ratio pointed by l .

As there can be only one possible tap ratio at once, the following constraint is necessary:

$$\sum_{a=1}^{N_L} l_a = 1 \quad (E.9)$$

4 SECURITY

An optimal state is searched with some N-K circuit contingencies. This means that with or without modification of the topology or generations, the removing of a circuit does not imply overloads.

Contingencies are taken into account by repeating as much as the number of events all the network constraints [16]. The N security of the OPF calculation is ensured with:

$$A\theta = P - C \quad (E.10)$$

and

$$\forall (ij) \in O, \quad |T_{ij}(\theta)| \leq \bar{T}_{ij} \quad (E.11)$$

where:

- A is the network susceptance matrix;
- θ is the vector of voltage angles;
- P is the unit active power output vector;
- C is the bus active power consumption vector;
- O is the set of circuits defining the network.

The N-k security is ensured with the same type of constraints:

$$\forall k \in K, \quad A^k \theta^k = P - C \quad (E.12)$$

and

$$\forall k \in K, \forall (ij) \in O_k, \quad |T_{ij}^k(\theta^k)| \leq \bar{T}_{ij}^k \quad (E.13)$$

where:

- K is the set of considered N-k circuit contingencies;
- O_k is the set of circuits defining the network for the contingency k .

A limitation of this approach is that the size of the problem (variables and constraints) increases linearly with the number of contingencies. For transmission networks this limitation is real since the base case is already a large-scale problem. Fortunately, very few contingencies are in fact significant because others dominate them. Thus a systematic N-k security is not necessary and the scope can be reduced to a small number of interesting cases. Alternatively, a N-k security analysis can be run before this optimization in order to select the most dangerous contingencies.

5 OBJECTIVE

The objective is the minimization of a function F_{obj} composed with two terms:

$$F_{obj} = \sum_{i=1}^{ND} (1-\alpha) |P_i - P_i^0| + \alpha \lambda \quad (E.14)$$

where:

- ND is the number of pre-defined units;
- P_i^0 is the initial value of active power generation of the unit i (a pre-defined unit);
- λ is an integer function indicating the total number of changes from the initial configuration concerning: the topology, the injections switching of supplementary units and the tap ratios of phase shifting transformers;
- α is a weighting factor in the range $[0,1]$.

The first term of (E.14) indicates the necessity to reduce as much as possible the modification of the current generation for pre-defined units. The second term reveals that it is not recommended, for practical implementation or time-limited reasons, to do many opera-

tions. The λ function is a count of variations of Boolean variables from their initial values associated to the taps of phase shifting transformers, the buses merging, the connection of a circuit and the presence of supplementary units. The weighting factor α permits operators to balance between these two terms to ensure the security. Generation costs could be considered for pre-defined and supplementary units with an extended formulation.

Preventive and curative security modes can be studied (see Figure 6 and 7). The preventive mode means a strong sharing of information between the base case and the contingencies. Information includes the generation of supplementary and pre-defined units, the taps of phase shifter transformers and the topology. The curative mode authorizes more flexibility on these variables to solve constraints on N-k. In this last case, fixed values for pre-defined units are in fact not necessary.

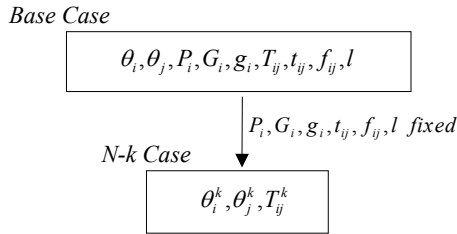

Figure 6: Variables treatment in preventive mode.

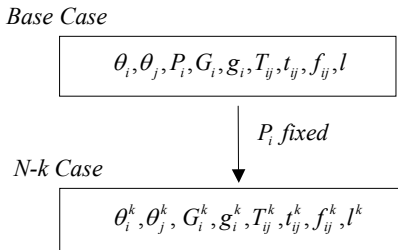

Figure 7: Variables treatment in curative mode.

6 NUMERICAL EXPERIMENTS

6.1 A small test case

For the comprehension, a small 5-buses test case is proposed.

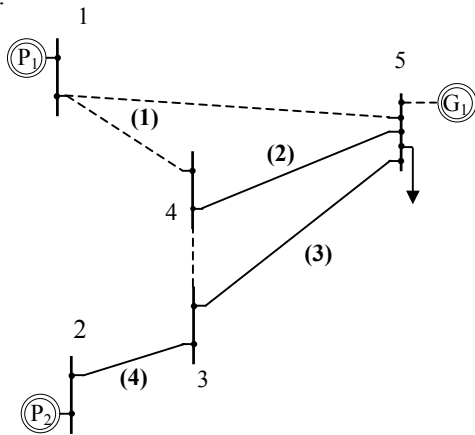

Figure 8: 5-buses test system.

The system is made of :

- four circuits with the same reactance value for simplicity (see Table 1);
- three generation units P_1 , P_2 and G_1 . All have the same generation range $[0, 100]$ MW;
- a load of 160 MW connected to bus 5.

Circuit	Bus Origin i	Bus Extremity j	\bar{T}_{ij} (MW)
(1)	1	4	100
(1)	1	5	100
(2)	4	5	80
(3)	3	5	80
(4)	2	3	100

Table 1: Circuits description.

Concerning the topology:

- circuit (1) can have two different connections depending on the extremity j ;
- buses 3 and 4 can be merged.

Concerning the dispatching problem:

- P_1 and P_2 are pre-defined units;
- G_1 is a supplementary unit;
- the load can not be shed.

The initial network configuration is depicted by the figure below:

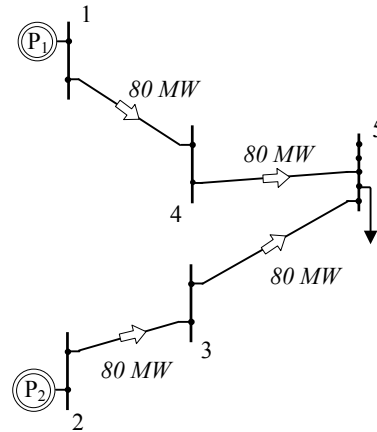

Figure 9: Running configuration.

From this network state, the outage of circuit (3) is considered. Then new configurations are calculated with the proposed modeling to satisfy the preventive and the curative security as mentioned on Figures 6 and 7. The corresponding detailed results are presented in Table 2 for both security modes. For an easier analyze of results, maximum active power flows on the N-1 are taken equal to the N values for all calculations:

$$k = 1, \forall (ij) \in O_k, \quad \bar{T}_{ij}^k = \bar{T}_{ij} \quad (\text{E.15})$$

Mode	Preventive		Curative	
Variables	$\alpha = 0$	$\alpha = 1$	$\alpha = 0$	$\alpha = 1$
F_{obj}	0	2	0	0
$\sum_{i=1}^{ND} P_i - P_i^0 $	0	80	0	0
λ	3	2	2	0
P_1	80	10	80	80
P_2	80	70	80	80
G_1	0	80	0	0
T_{14}	0	10	0	80
T_{45}	40	40	0	80
T_{35}	40	40	80	80
T_{23}	80	70	80	80
T_{15}	80	0	80	0
T_{14}^k	0	10	0	0
T_{45}^k	80	80	80	80
T_{35}^k	0	0	0	0
T_{23}^k	80	70	80	80
T_{15}^k	80	0	80	80

Table 2: Detailed results for preventive and curative security.

Figure 10 and 11 show the configuration results of preventive mode for $\alpha = 0$ and $\alpha = 1$.

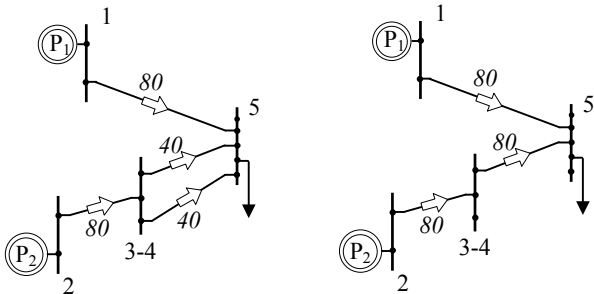

Figure 10: N and N-1 results for the preventive mode ($\alpha = 0$).

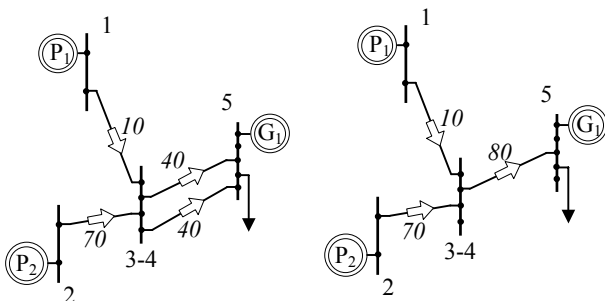

Figure 11: N and N-1 results for the preventive mode ($\alpha = 1$).

In the same way, Figure 12 and 13 show the configuration results of curative mode for $\alpha = 0$ and $\alpha = 1$.

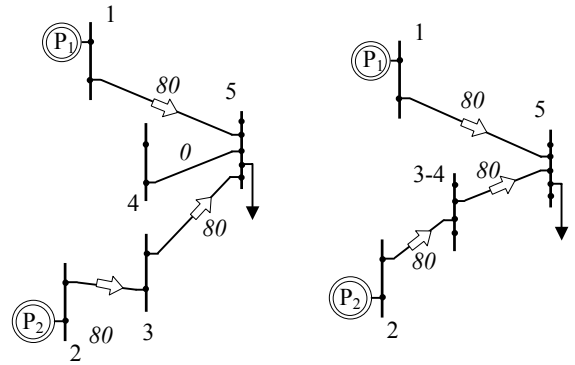

Figure 12: N and N-1 results for the curative mode ($\alpha = 0$).

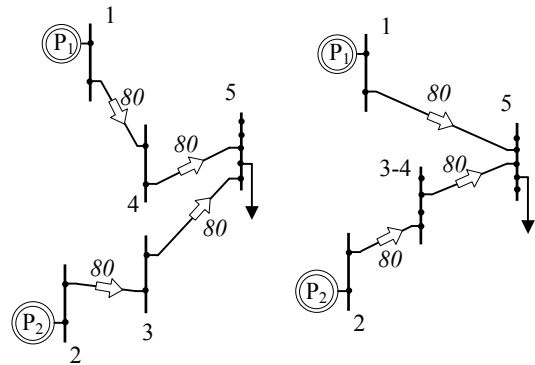

Figure 13: N and N-1 results for the curative mode ($\alpha = 1$).

This small problem demonstrates how important is the choice of α parameter in the flows and topology results. Nevertheless, the simultaneous optimization of the topology and dispatching problem seems to be convenient for security purposes. This is confirmed with the following real problems.

6.2 Eastern French region

The goal is to ensure the security in a preventive way when 400/225 kV autotransformer contingencies are simulated defining two N-1 cases. To reach this objective, the operator can modify the topology of three substations and call for the generations of four thermal units. The topology modification involves the modeling of two buses merges and one change of a circuit connection.

Data do not directly come from a snapshot. Nevertheless they are representative of encountered problems in the zone. The problem to solve is made of 1112 buses, 1597 circuits and 52 units. Consequently, the optimization problem is a MILP with 22876 lines (constraints), 13148 columns (13141 continuous and 7 binary variables) and 4808 non-zero elements. For a α parameter value, this problem is solved in less than 20 seconds by the RTE MILP solver.

The following figures show the results of the N-1 preventive security mode for several α values. At Figure 14, the linear (piecewise-linear) behavior of the objective function according to α parameter is established.

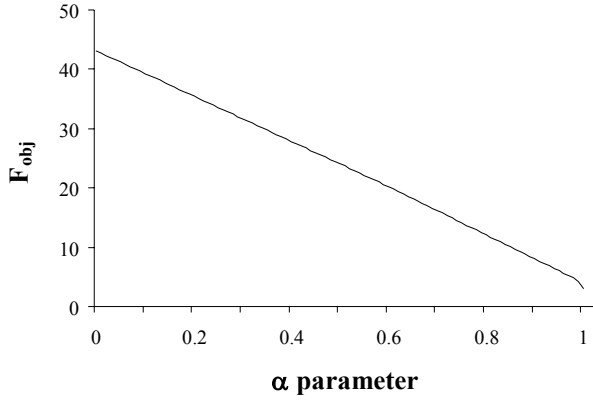

Figure 14: F_{obj} objective function values.

As it can be seen in Figure 15, the necessary generation modification is stable for a large range of α values. This is only for values near to 1, that is to say when the topology invariance is strongly searched, that the generation variations highly increase.

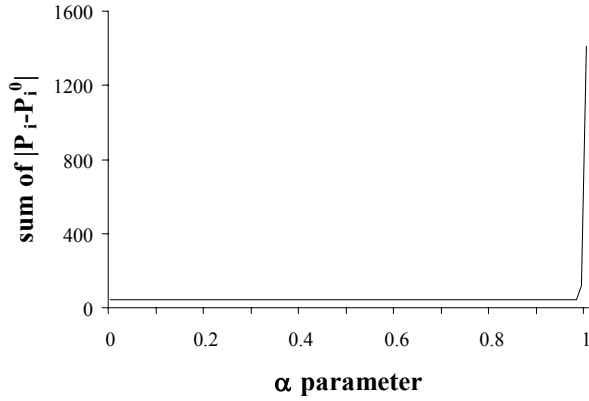

Figure 15: Sum of generation variations of pre-defined units.

Figure 16 presents the number of topology modifications. This number decreases suitably with the growth of α . The last benefits on λ , obtained for α values near to 1, are counterbalanced by the explosion of generation deviations.

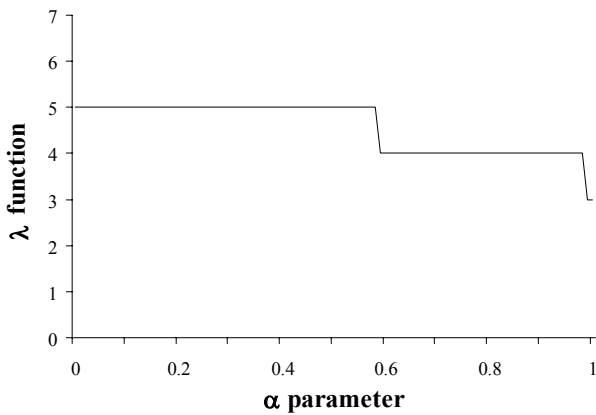

Figure 16: Number of modifications from the initial configuration counted by the λ function.

6.3 Center French region

The curative security is searched when six N-2 contingencies of 400 kV circuits are simulated. A particular interest is the presence of a phase shifting transformer in the region with 33 taps. In addition to its curative action, the topology can change according to two circuit disconnections and three injections switching.

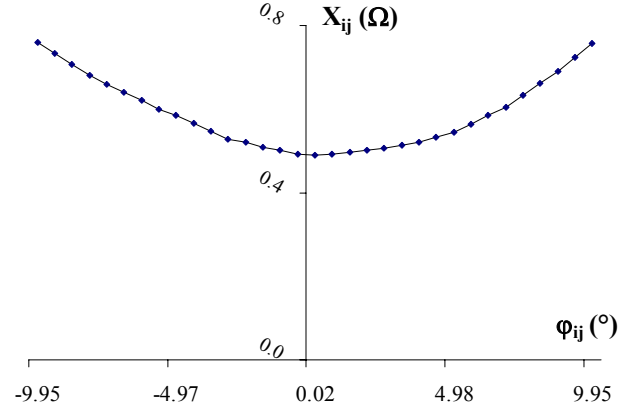

Figure 17: Phase shifting transformer reactance as a function of the phase for 33 taps.

Data directly come from a snapshot. For better results, the losses are taken into account as small fictive loads at each extremity of all circuits. Table 3 gives the deviation results for extreme values of α remembering that each tap change of the transformer is counted by the λ function. As it can be seen the non-modification of the topology is always compensated for a large generation deviation of pre-defined units.

Mode	Curative	
	$\alpha = 0$	$\alpha = 1$
Variables		
$\sum_{i=1}^{ND} P_i - P_i^0 $	0	40203
λ	26	0

Table 3: Objective function terms.

The problem is made of 973 buses, 1359 circuits and 223 units. The calculation matrix has 48098 lines (constraints), 27806 columns (with 223 binary variables) and 105087 non-zero elements. Both simulations were completed within a computation time of 20 minutes on a Pentium IV 2GHz with 1 Go of RAM. This time is longer because of the number of considered contingencies and binary variables. It is still clearly acceptable for operational considerations.

Figure 18 demonstrates the systematic participation of the phase shifting transformer to alleviate constraints for all the contingencies. An interesting work could be the study of a non-systematic curative participation of the phase shifting transformer. This participation would be conditioned by the flow values on the circuits monitored by the transformer.

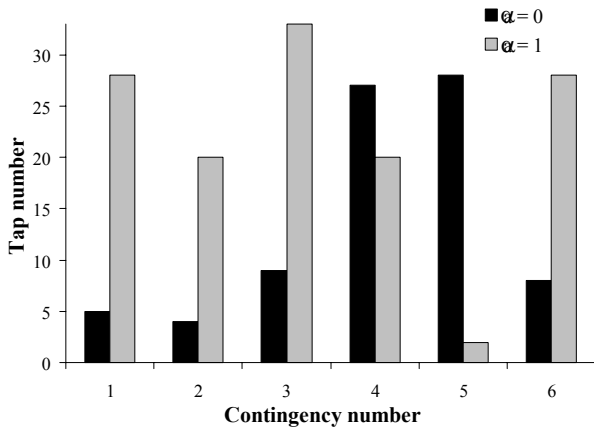

Figure 18: Tap results for each contingency.

7 CONCLUSION

This paper proposes a linear mixed-integer formulation of generation levels and topology optimization problems for the security management of the transmission network. Two results on the French network show the effectiveness of the method for large-scale problems.

Nevertheless, the validation of obtained results still has to be done with an AC simulator for security analysis. It is highly probable that some adjustments will need to be done. Moreover, unit contingencies are not presented here. At the present time it is an important lack for a serious consideration of the security. This would be treated similarly since the necessary MW compensation can be modeled as a mixed integer linear problem.

In addition to these improvements, authors wish to continue the development of this work with a particular interest on the modeling of devices behavior on contingency situations. This can include: a conditional curative action of phase shifting transformers, the calculation of curative load shedding as a part of the load or the simulation of automatons with precedence constraints.

REFERENCES

- [1] M. Pereira, L. Pinto, S. Cunha and G. Oliveira, "A decomposition approach to automated generation-transmission expansion planning", *IEEE Transactions on Power Apparatus and Systems*, vol. Pas-104, no. 11, pp. 3074-3083, November 1985
- [2] V.A. Levi and M. S. Calovic, "A new decomposition based method for optimal expansion planning of large transmission networks", *IEEE Transactions on Power Systems*, vol. 6, no. 3, pp. 937-943, August 1991
- [3] R. Romero and A. Monticelli, "A hierarchical decomposition approach for transmission expansion planning", *IEEE Transactions on Power Systems*, vol. 9, no. 1, pp. 373-380, February 1994
- [4] S. Binato, M. V. F. Pereira and S. Granville, "A new Benders decomposition approach to solve power transmission network design problems", *IEEE Transactions on Power Systems*, vol. 16, no. 2, pp. 235-240, May 2001
- [5] R. Gonzalez, M.-P. Bongrain and A. Renaud "Unit Commitment handling transmission constraints with an interior point method", *Proceedings of the 13th PSCC*, pp. 715-723, 1999
- [6] S.M. El-Sobki, M.M. El-Metwally, M.A. Farrag, "New approach for planning high-voltage transmission networks", *IEE Proc-C*, 133(5), pp.256-262,1986
- [7] G. Latorre-Bayonna and I.J. Pérez-Arriaga, "Chopin: a heuristic model for long term transmission planning", *IEEE Transactions on Power Systems*, vol. 9, no. 4, pp. 1886-1894, November 1994
- [8] G. C. Oliveira, A.P.C. Costa and S. Binato, "Large scale transmission network planning using optimization and heuristic techniques", *IEEE Transactions on Power Systems*, vol. 10, no. 4, pp. 1828-1834, November 1995
- [9] R.A. Gallego, R. Romero and A. J. Monticelli, "Tabu search algorithm for network synthesis", *IEEE Transactions on Power Systems*, vol. 15, no. 2, pp. 490-495, May 2000
- [10] L. Bahiense, G. C. Oliveira, M. Pereira and S. Granville, "A Mixed Integer Disjunctive Model for Transmission Network Expansion", *IEEE Transactions on Power Systems*, vol. 16, no. 3, pp. 560-565, August 2001
- [11] N. Alguacil, A. L. Motto and A. J. Conejo, "Transmission Expansion Planning: A Mixed-Integer LP Approach", *IEEE Transactions on Power Systems*, vol. 18, no. 3, pp. 1070-1077, August 2003
- [12] Y. Hassaïne, B. Delourme, M. Sidorkiewicz and E. Walter, "Identification of the Topology of Power Systems Networks via Mixed Integer Inequalities", IEEE Power Engineering Society, General Meeting, Denver, Colorado, USA, 6-10 June 2004
- [13] A. Bemporad and A. Morari, "Control of Systems Integrating Logic, Dynamics, and Constraints", *Automatica*, vol. 35, no. 3, pp. 407-427, March 1999
- [14] L.A. Wolsey and G.L. Nemhauser, *Integer and Combinatorial Optimization*, Wiley-Interscience, New-York, USA, 1988
- [15] J. Tomlin, "On scaling linear programming problems", *Mathematical Programming Study*, vol.6, pp.42-47, 1975
- [16] G.C. Oliveira, S. Binato, L. Bahiense, L. Thomé and M.V. Pereira, "Security-constrained transmission planning: A mixed-integer disjunctive approach", Optimization Online an e-print site for the optimization community, <http://www.optimization-online.org>, Applications – OR and Management Sciences, August 2004