

# SIMPLIFIED RELIABILITY CALCULATION OF ELECTRICAL NETWORKS BY AUTOMATIC DETERMINATION OF RELEVANT OUTAGE COMBINATIONS

Song Cheng

Institute of Power Systems and Power Economics  
RWTH Aachen University, Germany  
sc@iaew.rwth-aachen.de

**Abstract – In probabilistic reliability analysis, especially for meshed networks, overlaps of stochastic events should be considered. For the determination of the consequences of such outage combinations, time-consuming load flow calculations are required. Thus, with increasing size of the networks to be analyzed, the calculating time for reliability analysis will increase superproportionally, on the one hand due to the increasing number of possible combinations and on the other hand due to more time needed for load flow calculations. This could lead to unacceptably long calculating time and cause computer memory problems in practice and thus impede widespread applications. However, not all possible outage combinations are relevant and it is possible to select them in advance. The selection process is quite laborious even for experienced users. For the analysis of the consequences of outage combinations, information about the load flow after each outage combination is required. A standard load flow algorithm, however, is not practicable for large networks due to the long calculating time. For this reason, a new approach to estimate the load flow after outage combinations is developed. This new approach and a comparison of the calculating time as well as deviations with the standard load flow algorithm are presented. First applications show that with this newly developed method, the calculating time for probabilistic reliability analysis can be reduced substantially without noteworthy deviation of results.**

**Keywords: probabilistic reliability analysis, outage combination, reduction**

## 1 INTRODUCTION

With the liberalization of electricity markets, system operators are compelled to maintain the supply reliability under increasing cost pressure. For this purpose, a quantitative analysis of supply reliability for network planning or evaluations of restructuring options is required.

Although various methods for quantitative reliability analysis are available, two factors impede their applications. System operators usually have their complete networks in their computer system, which normally include the high voltage network as well as the underlying medium voltage networks. In many cases, the users just want to consider a certain part of the whole network, for which a complete calculation of the whole network is not necessary or not possible at all due to the large scale of the network. However, users without detailed knowledge of the models used can hardly do the

demarcation by themselves. Furthermore, in probabilistic reliability analysis, especially for meshed networks, overlaps of stochastic events should be considered. Thus the calculating time could be quite long since the number of combinations can be considerably high for large networks. Both these problems can be solved by a method, which can select all relevant outage combinations regarding the supply reliability for the loads to be considered in advance.

Some general requirements on this method are:

- Identification of all relevant combinations regarding the supply reliability for the loads to be considered,
- Selectivity, which means only relevant combinations should be chosen,
- Substantial reduction of calculating time and
- Widespread usability, especially independent from any network structure.

Since these requirements are partly contradictory, it is necessary to find a compromise, which fulfills all these requirements sufficiently.

This paper illustrates a new technique, which permits quantitative reliability analysis for common distribution networks within acceptable calculating time by automatic selection of relevant outage combinations. In this paper, the saving of calculating time and the deviations compared with a complete calculation are discussed.

## 2 PROBABILISTIC RELIABILITY ANALYSIS OF ELECTRIC NETWORKS

### 2.1 Modeling of electrical networks

For the reliability analysis of electrical networks, a detailed model of the electrical network is necessary in order to model the protection function and the restoration process in case of supply interruption. Instead of the branch-node model used in load flow calculations, circuit breakers, disconnectors and busbars must be modeled explicitly (Fig.1).

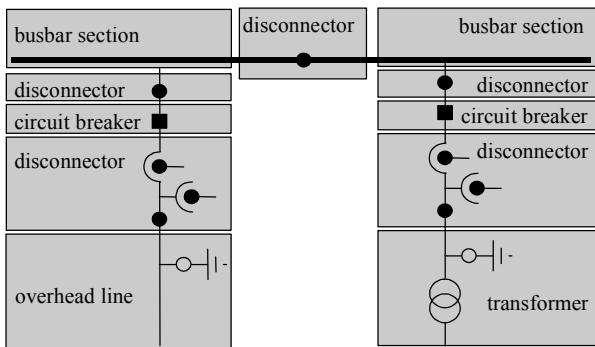

**Figure 1:** Modeling of electrical networks in reliability analysis

The data basis for probabilistic reliability analysis of electrical networks are credible failure statistics of the electrical equipment. In Germany, a unified data collection has been used by many utilities for decades. Since 2004, a new scheme, which is in accordance with the network model mentioned above, has been applied. This data collection scheme ensures reliable input data for probabilistic reliability analysis [1].

## 2.2 Modeling of failures

For the purpose of simulating various failures in practice, it is necessary to build corresponding models. In probabilistic reliability analysis, especially for meshed networks, failure combinations must also be considered. The following models have been proved to be appropriate by various applications [2]:

- Stochastic single failure:
  - Short circuit
  - Manuel disconnection
  - Common-mode-outage
  - Spontaneous release of circuit breaker
- Failure during maintenance,
- Overlapping of stochastic single failures,
- Dependent multiple failures
  - Multiple earth fault
  - Malfunction of protection

It is to notice that it is not necessary to carry out explicit simulations for each model described above. Usually it is possible to deduce the consequences of other failure models from those of short circuit combinations. Thus, in the following, the work will be concentrated on the model of overlapping of short circuits.

With the help of the data collection scheme mentioned above, it is possible to determine the frequency and duration for the various failure models described here.

## 2.3 Procedure and calculating time of probabilistic reliability analysis

Two different approaches can be used for probabilistic reliability analysis.

- The simulative approach can simulate the occurrence of failures of any distribution and thus has a high accuracy of results. However, the long

time needed for convergence is the main problem of this approach.

- The analytical approach, which has certain restrictions like the distribution of the durations of the failures, can normally obtain the results with sufficient accuracy within much shorter time and is increasingly used in various practical applications [3].

An overview of a common procedure for the analytical approach is shown in Fig.2.

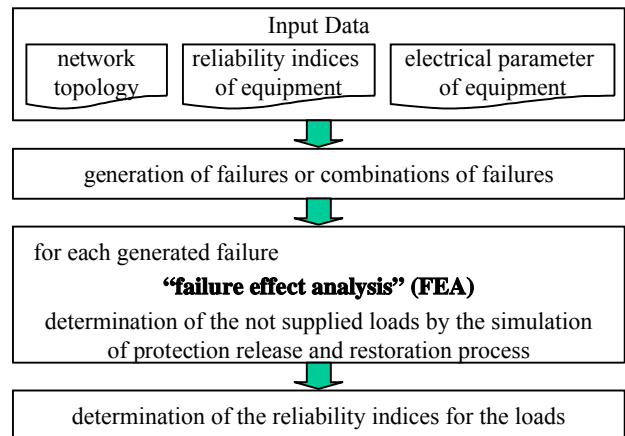

**Figure 2:** Procedure of the analytical approach

The analytical approach consists of two parts. In the first part, so called "failure effect analysis", the consequences of single outages or outage combinations are determined by simulating outages and the corresponding restoration process. Here, load flow calculations must be carried out. In the second part, the markov model is usually used to determine the probability of each system state and thus the indices of supply reliability.

The calculating time for the markov model is comparatively short and increases proportionally to the number of the outage combinations to be analyzed. The calculating time for the "failure effect analysis" increases superproportionally, on the one hand due to the increasing number of possible combinations and on the other hand due to the time needed for load flow calculations. This can lead to unacceptably long calculating time and computer memory problems.

Both the simulative approach and the analytical approach can benefit from the reduction of the outage combinations to be considered.

## 2.4 Available techniques for the reduction of calculating time

Certain techniques have been applied in various applications to make probabilistic reliability analysis possible for real networks.

For components with identical outage consequences, it is not necessary to carry out "failure effect analysis" individually. An example is the overhead line and the neighboring disconnector in Fig.1. The consequences of the outage of the overhead line can be directly adopted

for the neighboring disconnecter. Furthermore, combinations with very small probability or frequency are usually omitted. However, the possible large number of such combinations is not considered in the available methods. For example, busbars are quite reliable equipment and thus the simultaneous outages of two busbars are very seldom. In a large network, however, the number of such combinations is very high. The sum of the consequences of all such combinations could be significant and thus, should be considered.

These techniques are used and extended in this paper. In addition, approaches, which are capable of dealing with calculation of part of the networks, are developed.

### 3 CRITERIA FOR THE DETERMINATION OF RELEVANT OUTAGE COMBINATIONS

Due to the large number of components to be considered in the reliability analysis for electrical networks, it is not possible to consider all possible combinations. Certain criteria must be used for the selection of the relevant combinations.

A module, which can consider the frequency of single combinations and the number of such combinations, is developed. With the help of this module, an investigation was carried out for several large-scale real networks. The results show that in high voltage networks, the combinations of circuit breakers, disconnectors and busbar sections can usually be omitted. The failure statistics in Germany are applied in the investigation.

In a large network, the consequences of most of the outage combinations are exactly the same as the sum of the consequences of the single outages involved. Thus, it is not necessary to carry out the "failure effect analysis" for these combinations. For example, in the sample network in Fig.3, the consequence of the outage combination of L1 and L2 is the same as those of single outages of L1 and L2. Thus, this combination is not relevant. For the line L2 and L3, a single outage will not cause any supply interruption. However, a simultaneous outage of L2 and L3 leads to the supply interruption of load 1 and load 2. Thus, this combination is relevant.

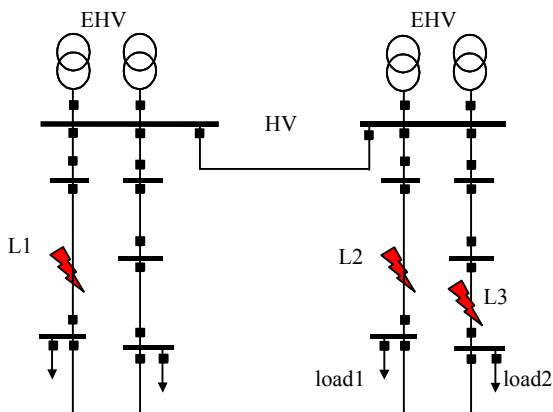

**Figure 3:** Consequences of outage combinations in comparison to those of single outages

The consequence of an outage is considered as the supply interruption of loads and corresponding durations. Supply interruptions can be classified into the following two categories according to the cause of disconnection:

#### - Interruption due to network structure

This type of interruption occurs immediately after the outage when the connection between the load and the network is interrupted by protection release or manual disconnection. This resultant supply interruption is unambiguous and can be determined either by load flow calculation or by standard search algorithms like Depth First Search or Breadth First Search etc.

#### - Interruption due to insufficient transmission capacity

Electrical equipment can normally endure a certain degree of overloading for a short time. If this short period is exceeded, measures must be carried out to reduce the overloading. Different possibilities are available in practice. System operators can either disconnect the equipment manually or by usage of automatic protection system. An alternative here is to shed certain loads according to their priorities to minimize the consequences of the overloading. Thus, the load interruption duration cannot be determined without the detailed simulation of the restoration process, which requires much detailed operational information and high calculating expenses. A worst-case estimation can be done by successive disconnections of overloaded lines or transformers.

### 4 SELECTION OF RELEVANT COMBINATIONS FOR RELIABILITY ANALYSIS

#### 4.1 Overview

In the first part of the selection process, with the help of the module mentioned above, combinations of very small probability are selected out and are thus not considered in the further analysis. For all remaining combinations, the following analytical steps are carried out (Fig.4).

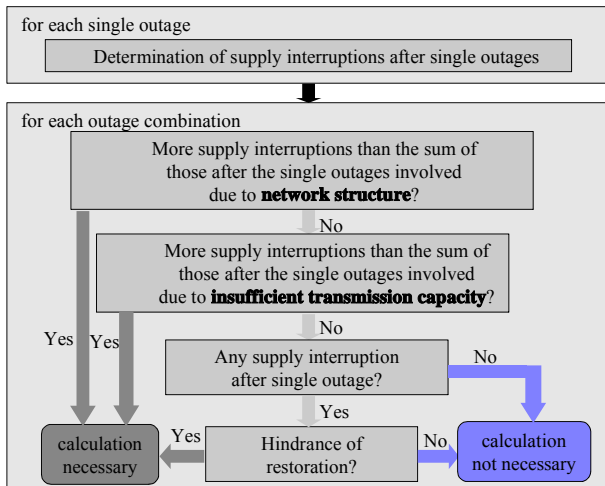

**Figure 4:** Overview of the selection process

#### 4.2 Analysis of single outages

The first step of the method is the determination of the consequences of single outages. This can be done by load flow calculations within a short time. The interruptions due to network structure can be exactly determined and a worst-case estimation for the interruptions due to insufficient transmission capacities can be done by successive disconnection of overloaded lines or transformers. The results in this step are basis for the comparisons in the next step. Furthermore, the results of load flow calculations after each single outage are stored for the estimation of the load flow after outage combinations. This will be explained in the following in detail.

#### 4.3 Analysis of outage combinations

The next step is the determination of the consequences of outage combinations. The application of standard load flow calculations for all possible combinations is not feasible for large networks due to unacceptably long calculating time. Separate determinations of interruptions due to network structure and due to insufficient transmission capacities are carried out. The Depth First Search algorithm is used to find out the loads not supplied after outage combinations due to network structure quickly. For the determination of the not supplied load due to insufficient transmission capacities, it is necessary to estimate the load flow after outage combinations. A new method is developed for a fast estimation of the load flow after outage combinations.

The basis of this new method is the storage of the results of the load flow after single outages. A simple superimposition is not appropriate due to possible interactions of outage consequences.

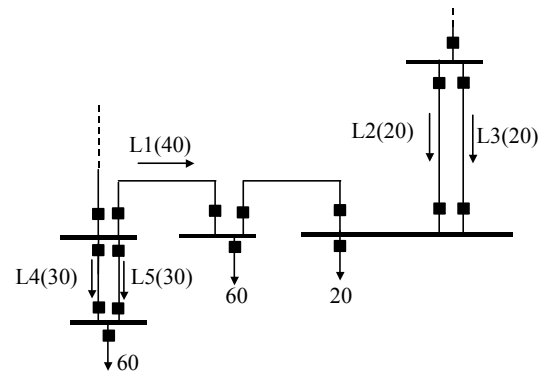

**Figure 5:** Estimation of load flow after outage combinations

A sample network is shown in Fig.5. The values in brackets are load flow values in normal operation. Table 1 shows the results of the (n-1) load flow calculation.

Change of flow	Single outage	
	L1	L2
$\Delta L1$	-40	2
$\Delta L2$	20	-20
$\Delta L3$	20	18

**Table 1:** Results of (n-1) load flow calculation

An estimation for the flow on L3 after the outage combination of L1 and L2 is to be carried out here. If a simple superimposition method is applied, the estimated value should be 58 according to the table above. This value is much smaller than the real flow after the outage combination, which is 80. The reason here is that the interactions of the outages are omitted. Therefore, a new approach is developed, in which assumptions for a linear distribution of the load flow are applied.

For the estimation of the load flow on line x after the simultaneous outage of line i and line j, two sensitivity factors are defined:

$$f_{i,j} = (I_{i,j} - I_j) / I_j$$

$$f_{j,i} = (I_{j,i} - I_j) / I_i$$

where

$I_i$ : load flow on line i in normal operation

$I_j$ : load flow on line j in normal operation

$I_{i,j}$ : load flow on line i in case of outage of line j

$I_{j,i}$ : load flow on line j in case of outage of line i

The following iterative steps are undertaken for the estimation. First, the flow on line i is set to 0 and  $I_j$  is distributed according to the sensitivity factors defined above. The flow on line j will be changed to  $I_j + I_i * f_{j,i}$  and the flow on line x will be changed to  $I_x + I_i * f_{x,i}$ . In the next step the flow on line j is set to 0 and  $I_j + I_i * f_{j,i}$  is distributed according to the sensitivity factors. It is to notice that after this step, the flow on line i will be a non-zero value again. Further steps will be

undertaken to distribute the remaining flows on line *i* and line *j* until the flows on line *i* and line *j* are smaller than a given small value. Table 2 shows the change of flow on the lines during this iterative process. The algorithm converges within only a few steps.

Step	L1	L2	$\Delta L3$	$\Delta L3$ cumulative
0	40	20	0	0
1	0	40	20	20
	4	0	36	56
2	0	2	2	58
	0.2	0	1.8	59.8
3	...	...	...	...

**Table 2:** Change of flow during the iterative load flow estimation

The outage of a busbar or a switchgear can be considered as the simultaneous outage of all outgoing lines. The iterative estimation method described above can be extended to deal with it. For the outage combination of two lines, the following equation can be used:

$$I_{x,ij} = \frac{(I_i \cdot f_{x,j} + I_j \cdot f_{x,i} + I_i \cdot f_{i,j} \cdot f_{x,i} + I_j \cdot f_{j,i} \cdot f_{x,j})}{1 - f_{i,j} \cdot f_{j,i}} + I_x \quad (1)$$

where

$I_{x,ij}$ : load flow on line *x* in case of outage of line *i* and line *j*

It is to notice that the application of this new method may be difficult in some unusual cases, for example when the flows in normal operation are very small and the sensitivity factors are larger than 1. Such cases can be detected in advance and standard load flow calculations will be carried out.

To implement this method, separate estimations for active power and reactive power are carried out. The feasibility of this estimation approach has been verified in numerous networks.

Fig.6 shows the application of this new method in a sample network. For each outage combination a standard load flow calculation and a load flow estimation using the new method are carried out. Deviations of load flows on all lines are evaluated and the maximum values and average value are illustrated. The calculating time is approximately 5% of the standard load flow calculation. The maximum deviations are less than 3% of the line capacities in most cases. This accuracy is normally adequate for reliability calculations.

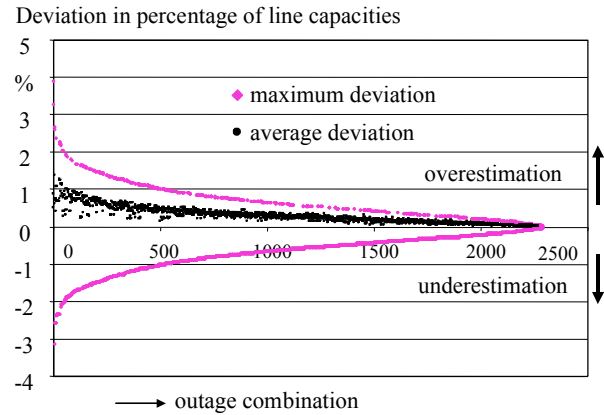

**Figure 6:** Deviation of the load flow estimation

With the estimated load flow information it is still not possible to determine the loads not supplied due to insufficient transmission capacities. For this a simulation of the corresponding disconnections and corresponding load flow calculations is necessary. However, the goal in this step is to determine whether more loads are not supplied due to insufficient transmission capacities in comparison to the case of single outages. Thus, a comparison of the degree of overloading is carried out here.

For any line or transformer, if both the following two conditions are fulfilled:

- $I_{x,ij} >$  capacity of line *x*, which means that the line is overloaded after the outage combination, and
- $I_{x,ij} > I_{x,i}$  and  $I_{x,ij} > I_{x,j}$ , which means that the loading after the outage combination is higher than the loading after any single outage involved,

the combination *i* and *j* will be regarded as relevant because more loads could be disconnected due to more severe overloading in comparison to single outages.

For the evaluation of the supply reliability not only the frequency of interruptions must be considered, but also the duration of interruptions. In certain cases, although the affected loads after an outage combination is the same as the sum of those after the single outages involved, the duration of interruption can be substantially longer. Fig.7 shows an example. After a short circuit of busbar section 1, load 1 will not be supplied until the second transformer, which is disconnected in normal operation, is switched on. For the outage combination of busbar section 1 and line 1, although still the same load is affected, the duration of interruption can be much longer since load 1 cannot be supplied until busbar section 1 or line 1 is repaired. Thus, this combination is relevant.

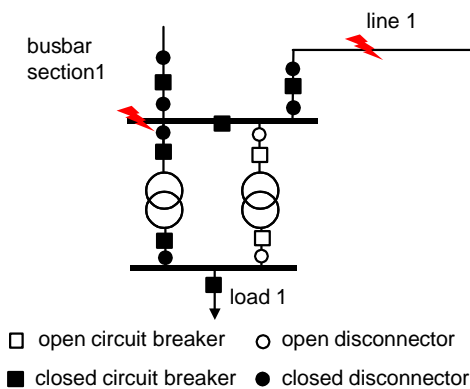

**Figure 7:** Hindrance of the restoration process

To determine whether the outage of a certain component in the system (C2) could hinder the restoration process after the outage of another component (C1), the following steps are undertaken.

First, in the (n-1)-analysis, it will be determined whether any load is affected after the outage of C1. If not, no restoration process is necessary and thus, the combination is not relevant in consideration of restoration. In case of supply interruption, a search for a connection from the interrupted loads to the slack is carried out. To make full use of all available switching possibilities all switches are closed except those, which are necessary for the disconnection of the affected component. The shortest-path algorithm is applied to find out a connection between the loads not supplied and the slack. If C2 is part of this connection, the combination C1 and C2 should be considered since restoration could be hampered.

#### 4.4 Extra measure for calculation of part of the network

The process explained above is applicable to the calculation of a whole network as well as for the calculation of a selected part of the network. For the second case, an extra measure is carried out to reduce the calculating time.

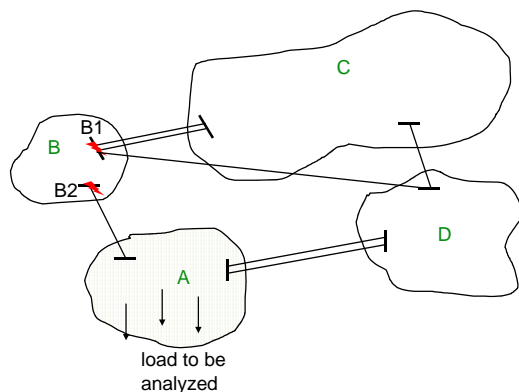

**Figure 8:** A schematic high voltage network

This measure will be explained with the help of a schematic network as illustrated in Fig. 8. An evaluation of the supply reliability of the loads in Area A is to be

carried out. In case of outage of both busbar B1 and B2, all loads in the Area A can still be supplied via the connection from Area D. Therefore, all outage combinations in Area B are not relevant for the supply reliability of the loads in Area A. In the developed method, load flow calculations are carried out for the outage combinations of selected busbar sections, which divide the network in two separate parts. If the loads to be analyzed are still supplied after the outage combination, all outage combinations of the components in the part of network, which is not supplied, can be neglected.

## 5 APPLICATION OF THE DEVELOPED METHOD IN RELIABILITY ANALYSIS

To test the usability of the developed technique, the probabilistic reliability calculation program RAMSES, which is developed in the Institute of Power Systems and Power Economics, RWTH Aachen University, is applied. Two sample networks are used. The first network is a 110-kV network with 19 stations. Table 3 gives an overview of the components in this network.

Component	Number
circuit breaker	66
disconnecter	147
busbar section	34
overhead line	21
Cable	3
total	271

**Table 3:** Overview of the number of components in the first sample network.

There are a total of 271 single components to be considered in this sample network. If the identical consequences of outages of different single components are considered, the number of the single components, for which an explicit “failure effect analysis” must be carried out, can be reduced to 181, which means the maximum number of combinations is 16290.

In a complete calculation, the “failure effect analysis” for all 16290 combinations is carried out. The calculating time for this reference case is 2564 seconds.

In a second calculation, the newly developed method is applied. It is found that 538 combinations are relevant, which is approximately 3% of all combinations. Among them, 459 combinations due to network structure, 49 combinations due to insufficient capacities and 30 combinations are selected due to hindrance of restoration. The whole calculating time is 84 seconds including 8 seconds to select the relevant combinations. A comparison of the results shows that there is no noteworthy difference in the results of the frequency and the probability of interruption (Fig. 9).

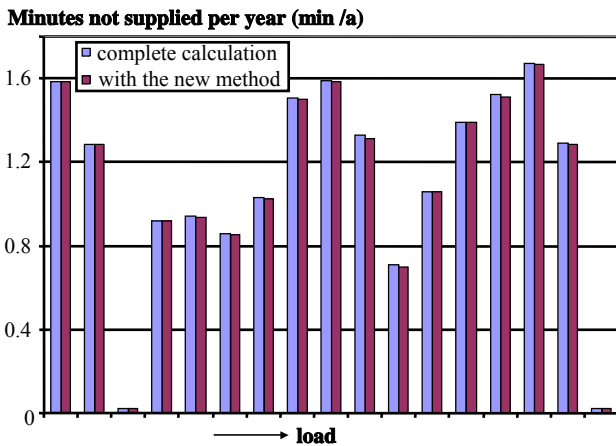

**Figure 9:** Comparison of the results

A second real high voltage network with underlying medium voltage transport networks is used to compare the results and calculating time between the whole network calculation and the calculation of part of the network. The network is shown in Fig.10 and the number of system components of this network is listed in table 4.

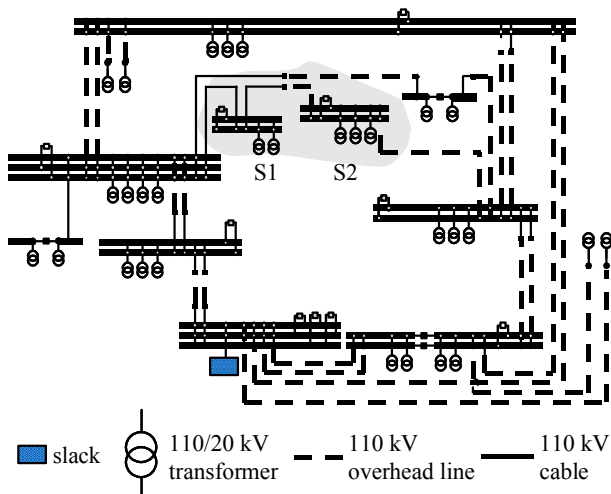

**Figure 10:** Sample network

Component	Number
circuit breaker	506
disconnecter	974
busbar section	137
overhead line	167
cable	48
transformer	28
total	1860

**Table 4:** Overview of the number of components in the second sample network.

The number of possible combinations is so high that a calculation of all combinations in the reliability calculation with common personal computers is not possible. Therefore, the results of the calculation of the whole network using the newly developed methods are used as reference. The calculating time is 6924 seconds, of which 2550 seconds are used for the selection of relevant combinations. 2418 combinations are selected, which is less than 2% of all possible combinations.

In a second step various loads are selected for part network calculation. Much less time is required for such calculations. For example, if only the supply reliability of station S1 and S2 is to be considered, only 428 combinations are selected and the whole calculating time is 1780 seconds. The results of reliability indices for the loads to be considered are the same as those of the whole network calculation. The larger the network to be analyzed is, the higher the saving potential of calculating time could be.

## 6 CONCLUSIONS

Probabilistic reliability analyses are required increasingly in practice. Long calculating time and manual demarcations are two main hindrances for the application of such methods. In this paper, a method, which permits quantitative reliability analysis for common networks within acceptable calculating time by automatic selection of relevant outage combinations, is introduced. Substantial time saving can be achieved with negligible deviations from the results of a complete calculation.

Further work will be concentrated on a simplified consideration of medium voltage networks and the integration of the developed method into a common network analysis software, as well as a profound verification of the method with typical network structures.

## REFERENCES

- [1] M. Obergünner, M. Schwan, C. Krane, K. von Sengbusch, C. Bock and D. Quadflieg, "Using the VDN statistic on incidents to derive component reliability data for probabilistic reliability analyses", *Elektrizitätswirtschaft*, pp 32-36, Vol. 15, July 2004
- [2] S. Cheng, H. Vennegeerts and K. von Sengbusch, "Computer-based probabilistic reliability analysis – Further development of RAMSES", Annual report of the institute of power systems and power economics, Aachen, Klinkenberg Verlag, 2003, ISBN 3-934318-46-0, pp 93-97
- [3] H.-J., Haubrich, "Reliability calculation for distribution networks", Aachen, Klinkenberg Verlag, 1996, ISBN 3-86073-492-X, pp 95- 97