

PID GOVERNOR FOR BLACK START

Atsushi Izena, Naoto Suzuki, Toshikazu Shimojo
 (Kyushu Electric Power Company Inc.)
 Kaiichiro Hirayama, Nobuhiko Furukawa, Takahisa Kageyama
 (Toshiba Corporation)

Abstract – The power system frequency during a black start period can be unstable because governor control constants of the hydro generators to be started first are generally designed to operate in the usual bulk power system. This paper reports on the power system frequency stability in a small-scale power system with hydro generators at the time of a black start, with an emphasis on the results of our study using an improved PID governor for power system frequency stability and quick response to meet criteria.

Keywords: black start, hydraulic generator, PID governor, governor control, analysis model, frequency control

1 INTRODUCTION

The power system of Kyushu Electric Power Company Inc. or KEPCO, whose size is about 19 GW, belongs to the Western Japanese power system (110GW, 60Hz) and has a 500kV and 220kV grid system in a looped configuration. It is determined, when the KEPCO power system collapse occurs, to first start some hydro generators as an initial power. Then these hydro generators are synchronized with each other. However, governor control constants are generally designed under the condition that hydraulic generators operate in the usual bulk power system. And a power system at a black start is very small compared with the usual power system. In this situation the power system frequency during a black start period can be unstable, if the same governor control constants as for the usual bulk power system are still used. And due to such an unstable power system frequency, the power system restoration after the blackout may fail again.

KEPCO specified governor performance criteria with frequency control for black starts as follows:

- 1) The power system frequency must be settled within 50 seconds to shorten the restoration time at a black start
- 2) Its fluctuation must be kept within $\pm 1\text{Hz}$ (1.67%)

PID governor responses of pumped storage hydraulic power turbines at a black start were studied and tested as to whether the governor could meet the above criteria.

Generally speaking, tuning of governor control constants is well known [1-5]. Moreover, a field test for such a governor model was also carried out and reported. Water time constant T_w of hydraulic system is a function of water flow Q that flows into a tunnel and a penstock. Damping coefficient D_m of turbine dynamics is calculated

as the rate of changes of load for frequencies [6-7]. Turbine speed changes are very small or negligible when hydro generators are synchronized with the large-scale power system. In this case, D_m of each hydro generator is not considered important for stability of the speed control system. In a small-scale power system like a black start power system, however, these T_w and D_m greatly influence governor's control stability. Authors thus carried out field tests for analysis of such governor control stability and improved the analysis models of D_m and servo system based on the field test results [8].

This paper reports on the results of our study using an improved PID governor for power system frequency stability and quick response to meet the criteria during black start operations, identifies some problems, and suggests a countermeasure.

2 MODELING OF GOVERNOR SYSTEM BASED ON FIELD TEST

2.1 Governor Control Structure

Figure 1 shows a block diagram from a governor control system to a hydraulic turbine supplying an isolated load at a black start. Figure 2 and Figure 3 show detailed block diagrams of the PID governor and hydraulic system. The servo system was shown in Figure 4

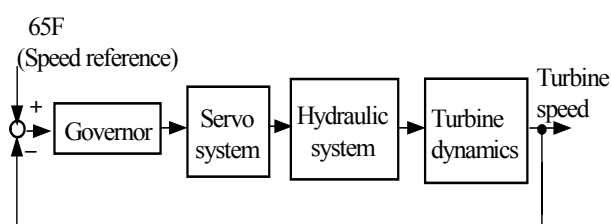

Figure 1: Governor system configuration with turbine dynamics

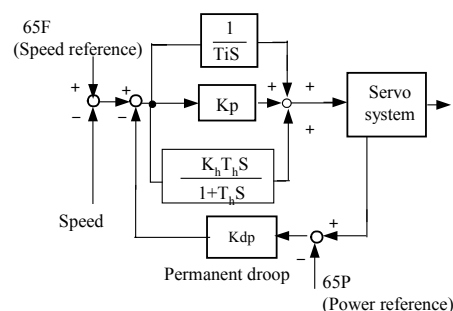
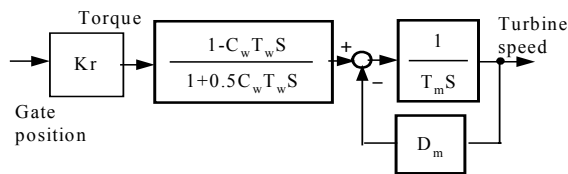

Figure 2: PID governor



$T_m=11.4(\text{Sec.}), T_w=1.7(\text{Sec.}), D_m=1.45, K_r=1.29$

Figure 3: Hydraulic system and turbine dynamics

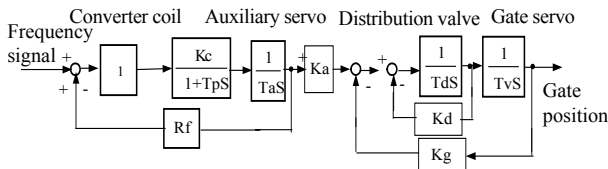

Figure 4: Frequency response test configuration using the actual servo system (under stopping of the turbine generator)

2.2 Frequency Response Test

The PID governor of pumped storage hydraulic power turbine (250MW) to be used for a black start was studied as to whether the governor response could meet the above criteria. An open loop frequency response test was conducted to the actual servo system. Since this PID governor was of a digital type, PID constants and algorithms were given by software. Test signals with various frequencies were put into the PID governor through an analog input board. Figure 4 shows the configuration of the frequency response test. Figure 5 shows the frequency characteristic drawn using the measurement data, and Figure 6 shows the frequency characteristic calculated with the configuration shown in Figure 4 and from the measurement value (Table 1). The servo system constants seemed to be correctly calculated, because Figure 6 well agreed to Figure 5.

2.3 Step Response Test

A step signal was put into the speed reference (65F) shown in Figure 1, and its transient response of the governor control system was measured. Figure 7 shows the results of a -1% step response test. Table 1 shows the servo system constants used in Figure 4.

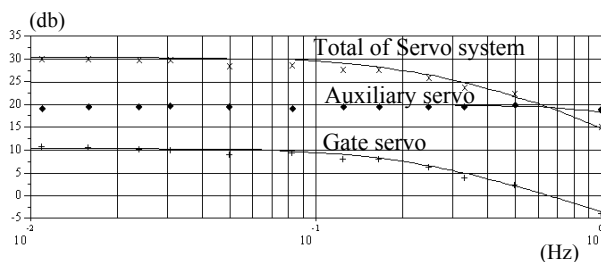

Figure 5: Servo system frequency characteristic of 250MW pumped storage hydraulic generator-measured

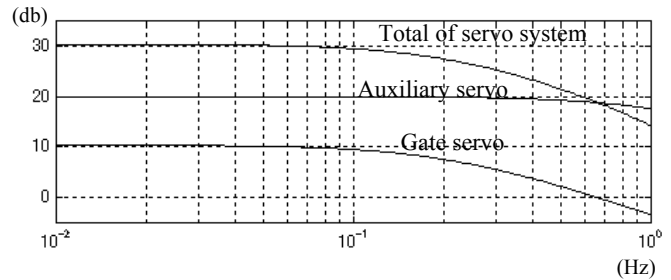

Figure 6: Servo system frequency characteristic of the 250MW pumped storage hydraulic generator calculated based on the measured data

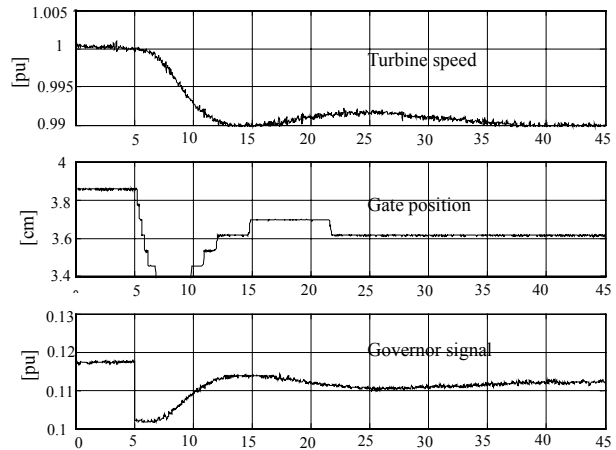

Figure 7: Governor response test record at -1% step change (Sec.)

Apparatus	Symbol	Unit	Value
Converter coil	T_p	sec	0.07
	K_c	cm/pu	1.0
Auxiliary servo	T_a	sec	0.02
	R_f	pu/cm	0.1
Distribution valve	T_d	sec	0.01
	K_a	cm/cm	0.7
	K_d	cm/cm	0.33
Gate servo	T_v	sec	0.5
	K_g	cm/cm	0.21

Table 1: Measured value of servo system constants

Moreover, the servo system constants in Figure 4 estimated through the frequency response test were used to simulate the -1% step response shown in Figure 8. It turns out that the simulation results well agreed to the test data. Therefore, it can be said that the governor control system model matches the characteristic of the actual control system with sufficient accuracy. The present governor control constants are shown in Table 2.

Symbol	Meaning	Value
K_p	Proportional gain.	1.5
T_i	Integral time constant	10
K_h	Differential gain	0.0
T_h	Differential time constant	0.0
K_{dp}	Permanent Droop	0.0

Table 2: Present governor control constants

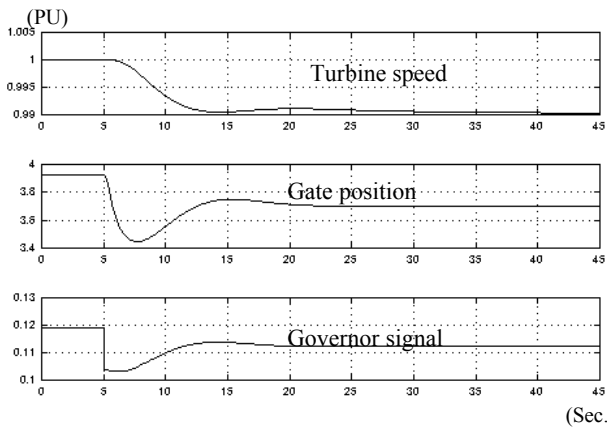

Figure 8: Governor response simulation at -1% step change

3 PUMPED STORAGE HYDRAULIC TURBINE GOVERNOR CONTROL SYSTEM FOR BLACK START

A governor control system of a hydro turbine consists of a governor, a servo system, a hydraulic system, and a turbine. The governor control system to be used for a black start was studied as shown below.

3.1 Evaluation of PID governor response for the pumped storage hydraulic turbine at a black start

In order to send power to load stably at the time of a black start, the power system frequency must be stable, and controlled within small fluctuation even when load is increased step-wise up to 5% of the maximum generator capacity with governor control. KEPCO specified governor performance criteria with frequency control for black starts as follows:

- 1) The power system frequency must be settled within 50 seconds to shorten the restoration time at a black start
- 2) Its fluctuation must be less than 1Hz(1.67%)

The PID constants in Table 2 were checked as to whether the simulated performance could meet the above criteria. Figure 9 was the simulation result of the power system frequency change when a generator load was increased step-wise from 60% to 65%. Similarly, Figure 10 is the simulation case from 80% to 85% load change.

The minimum turbine speed of Figure 9 and Figure 10 were lower than -1.67% (-1.0Hz) and exceeded the criteria. So those PID constants in Table 2 were not considered acceptable. Therefore, it is necessary to modify the present PID constants to new constants that can meet the criteria.

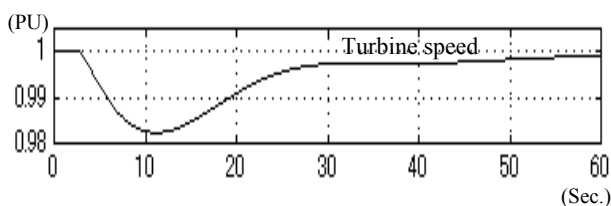

Figure 9: Governor response to 5% step-wise load increase from generator 60% load

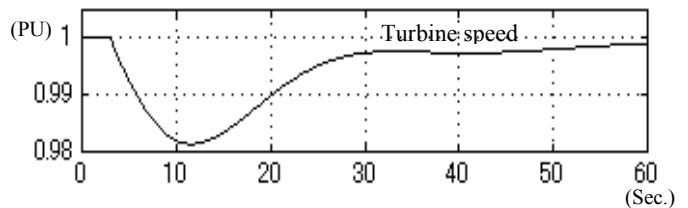

Figure 10: Governor response to 5% step-wise load increase from generator 80% load

3.2 Improved PID Constants for Black Start

New PID constants were contrived to improve the response to turbine speed changes quicker than that with the present PID constants. The improved PID constants based on the data of the servo system obtained by the field test are shown in Table 3. The dominant poles in the governor control system using them are shown in Table 4.

Symbol	Meaning	Value
K_p	Proportional gain.	2.5
T_i	Integral time constant	5.0
K_h	Differential gain	8.1
T_h	Differential time constant	1.27
K_{dp}	Permanent droop	0.0

Table 3: New governor control constants

No	Generator power	Dominant poles	
		Real part	Imaginary part
1	40%	-0.177	± 0.574
2	60%	-0.061	± 0.425
3	80%	-0.038	± 0.433
4	100%	-0.065	± 0.391

Table 4: Dominant poles on improved PID constants

Figure 11 is a bode diagram drawn on the same conditions as No.4 in the table 4. A phase margin is 40 degrees or more when a gain curve cuts across the 0db axis in Figure 11.

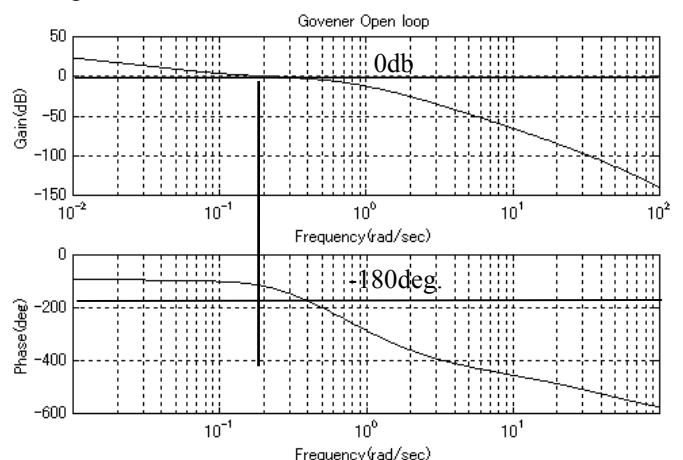

Figure 11: Governor system frequency characteristic of pumped storage hydraulic generator under application to new designed PID constants

The dominant pole with the current PID constants at generator power 100% is as follows.

Dominant pole: $-0.0896 \pm j0.186$

As shown above, the governor control system with the improved PID constants is stable at all the operating points of a generator, and it turns out that the response speed to turbine speed changes is improving as compared with the present PID constants.

Figure 12 and Figure 13 show the results of the simulation corresponding to Figure 9 and Figure 10. Table 5 is the summary of the simulation results. The improved PID constants can satisfy the criteria of -1Hz or less.

No	Figure	Turbine speed dip	Criteria
1	Figure12	0.9875p.u(-0.75Hz)	-0.0167p.u(-1Hz)
2	Figure13	0.985p.u(-0.9Hz)	Ditto

Note; Turbine speed 1p.u=400rpm(60Hz)

Table 5: Summary of simulation with improved PID constants

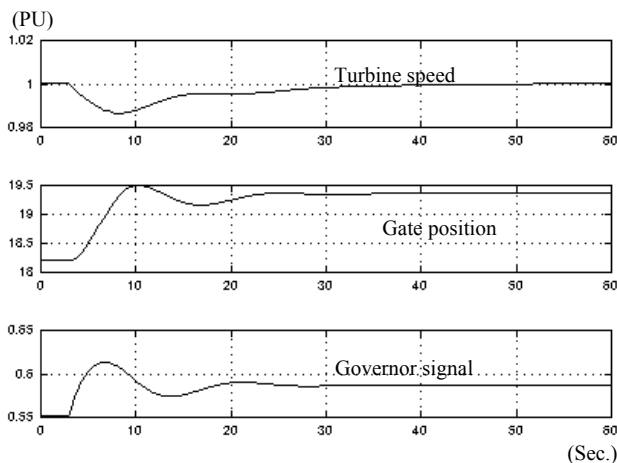

Figure 12: Governor response to 5% step-wise load increase from generator 60% load with improved PID

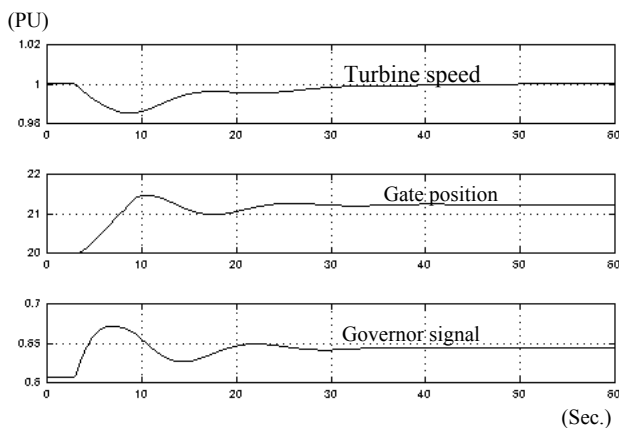

Figure 13: Governor response to 5% step-wise load increase from generator 80% load with improved PID

3.3 Study of Permanent Droop applied to Improved PID Constants

If two or more PID governors without permanent droop are used, generators cannot send power to load stably [8]. Permanent droop on a PID governor is mandatory used after a generator is connected to a power system. When permanent droop is used, as compared with the case where it is not used, a governor control loop becomes more stable but slow. Therefore, the design of PID constants to make the governor response quicker than that with the above-mentioned new PID constants is attained. The newly designed PID constants are presented in Table 6. The dominant poles calculated with this design are then presented in Table 7.

Symbol	Meaning	Value
K_p	Proportional gain.	3.0
T_i	Integral time constant	3.0
K_h	Differential gain	8.1
T_h	Differential time constant	1.27
K_{dp}	Permanent droop	0.05

Table 6: Governor control constants with permanent droop

Figure 14 is a bode diagram drawn under the condition of No.4 in Table 7. A phase margin is 30 degrees when a gain curve cuts across the 0db axis in Figure 14. This shows the speed control system is stable. Figure 15 shows the result of the simulation with the PID constants in Table 6. The simulation condition is same as Figure 13.

No	Generator power	Dominant poles	
		Real part	Imaginary part
1	40%	-0.183	± 0.573
2	60%	-0.063	± 0.425
3	80%	-0.069	± 0.371
4	100%	-0.094	± 0.327

Table 7: Dominant poles on improved PID constants with permanent droop

Comparing Figure 15 with Figure 13,

- 1) The overshoot to turbine speed in Figure 13 did not occur but it occurred in Figure 15 slightly.
- 2) The minimum turbine speeds are almost same.
- 3) The recovery times to 1p.u are almost same.

As mentioned above, the turbine speed changes by step load application to the generator in Figure 13 and Figure 15 show almost the same motion.

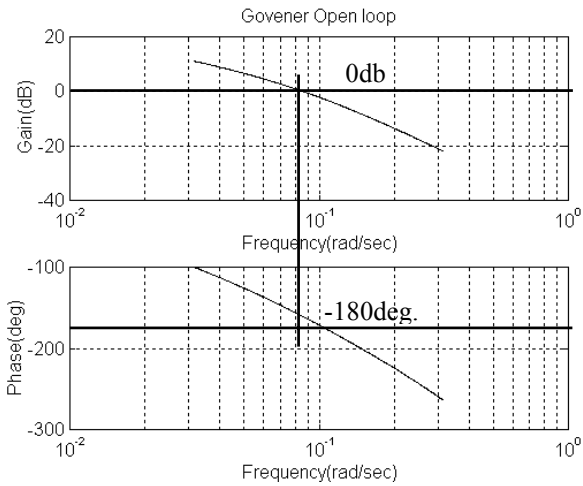

Figure 14: Governor system frequency characteristic of pumped storage hydraulic generator under application to PID constants in Table 6 with permanent droop

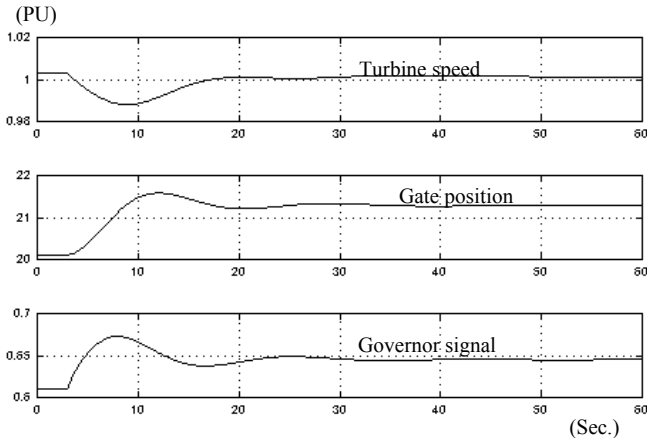

Figure 15: Governor response to 5% step-wise load increase from generator 80% load with PID in Table 6 with permanent droop

3.4 Evaluation of Permanent Droop

It is most effective that a hydraulic generator with the maximum capability carries out frequency control, PID governor without permanent droop, in a small-scale system like a black start. The PID governor with permanent droop makes an offset between a frequency reference and the power system frequency. Therefore, this governor cannot maintain the power system frequency to the rated frequency. Figure 16 is a small-scale power system configuration with three pumped storage hydraulic generators with PID governors in restoration process from a blackout. One of them maintains the power system frequency constant, and the other two governors are with permanent droop in service. Figure 17 shows the simulation results to evaluate whether the power system frequency can be stable and recover within ± 1 Hz when the total load of the power system in Figure 16 increased by 5% step-wise from the initial load. This simulation result showed that the power system frequency stayed within -0.8% (-0.48 Hz). These PID

governors, therefore, can meet the criteria that the maximum frequency drop is -1 Hz or less. The power system frequency was settled to the rated frequency within 50 seconds, proving that this improved PID constants could meet the criteria.

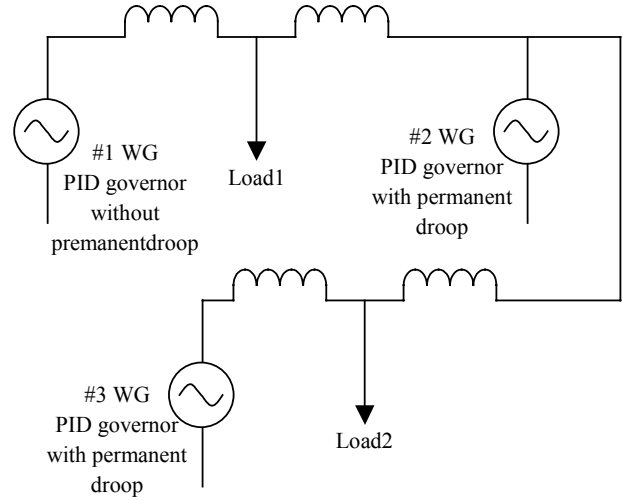

Figure 16: Three machines power system configuration with PID governor

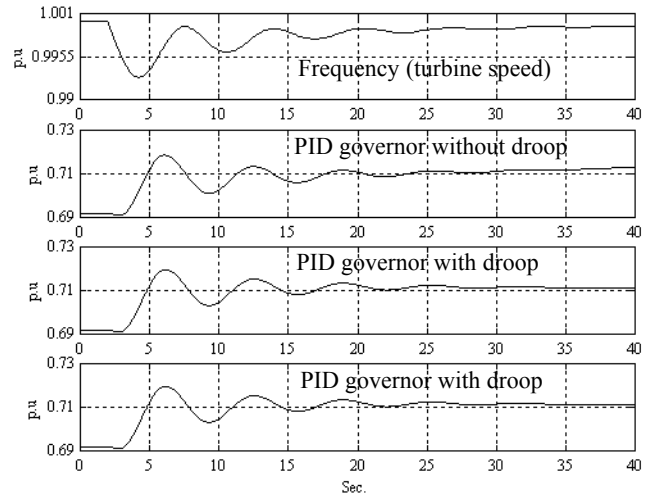

Figure 17: Governor response to 5% step-wise load increase from generator 60% load (100% is a total generator capacity of three generators.)

4 CONCLUSION

Generally speaking, tuning of governor control constants is well known. Moreover, a field test for such a governor model was also carried out and reported. But, a black start must be made from a small-scale power system. KEPCO plans to restore the power system using hydro plants as initial power sources. Fossil and nuclear power plants will then be started by receiving power from this small-scale power system.

The frequency stability is most essential to restore the power system at the early stage of a black start. This depends heavily on the governor performances. Based on the field test and the new design, we have obtained adequate governor constants. KEPCO verifies the new governor constants satisfy the frequency fluctuation and response speed specifications. The hydraulic plants proposed are operating normally in the bulk power system. For that purpose, the two settings are needed the conventional setting for normal operation and the new setting for black start. It turns out that the KEPCO power system can be smoothly restored from a blackout with those governor constants.

REFERENCES

- [1] IEEE recommended practice for preparation of equipment specifications for speed governing of hydraulic turbines intended to drive electric generators
- [2] Working Group on Prime Mover and Energy Supply Models for System Dynamic Performance Studies" Hydraulic turbine and turbine control models for system dynamic studies", Power Systems, IEEE Transactions on, Volume: 7 Issue: 1, Feb.1992, Page (s): 167 - 179
- [3] Vournas, C.D.;" Governor tuning and regulating capacity of hydroelectric units" WESCANEX 93. 'Communications, Computers and Power in the Modern Environment.' Conference Proceedings, IEEE, 17-18 May 1993,Page(s): 228 –233
- [4] Murphy, L.D.; Wozniak, L.; Whittemore, T.A.; "A digital governor for hydrogenerators" Energy Conversion, IEEE Transactions on Volume: 3 Issue: 4 , Dec. 1988 ,Page(s): 780 –784
- [5] C.K.Sanathanan,"A Frequency Domain Method for Tuning Hydro Governors."IEEE Transaction on Energy Conversion, Vol.3, No.1, March 1998
- [6] Louis N.Hannett, et.al, "Field Test to Validate Hydro Turbine-Governor Model Structure and Parameters" IEEE Transactions on Power System, Vol.9, No.4, November 1994, Page(s): 1744 -1751
- [7] Mansoor, S.P.; Jones, D.J.; Bradley, D.A.; Aris, F.C.; Jones, G.R.; "Stability of a pump storage hydro-power station connected to a power system", Power Engineering Society 1999 Winter Meeting, IEEE, Volume: 1, 31 Jan.-4 Feb. 1999,Page(s): 646 -650 vol.1
- [8] K.Furukawa, et.al, "Governor control study at the time of a black start", Power Engineering Society 2004 General Meeting, IEEE, June 6-10. PESGM2004-000448.PDF