

OPTIMAL PLACEMENT AND UTILIZATION OF PHASOR MEASUREMENTS FOR STATE ESTIMATION

Xu Bei, Yeo Jun Yoon and Ali Abur
Texas A&M University
College Station, Texas, U.S.A.
abur@ee.tamu.edu

Abstract – This paper presents a procedure by which new PMU locations can be systematically determined in order to render an observable system. The procedure is then extended to account for cases of loss of a single phasor measurement unit (PMU). Buses with zero and non-zero injections, and branches with power flow measurements are also accounted for in this generalized procedure. Several cases involving different power system and measurement configurations are presented where introducing few extra strategically placed PMUs minimizes vulnerability of the measurement system against the loss of single PMUs. The paper also develops a linear estimator based on strictly PMU measurements and investigates the computational performance as well as the bad data processing problem. Detection and identification of PMU failures are demonstrated via simulations.

Keywords: *State estimation, phasor measurement units, network observability, optimal meter placement, bad data processing, integer programming, graph theory.*

1 INTRODUCTION

State estimators provide optimal estimates of bus voltage phasors based on the available measurements and knowledge about the network topology. Until recently, available measurement sets did not contain phase angle measurements due to the technical difficulties associated with the synchronization of measurements at remote locations. Global positioning satellite (GPS) technology alleviated these difficulties and lead to the development of phasor measurement units (PMU). As the PMUs become more and more affordable, their utilization will increase not only for substation applications but also at the control centers for the EMS applications. One of the applications, which will be significantly affected by the introduction of PMUs, is the state estimator. This paper is concerned with two aspects of this issue. One is related to the proper placement and the other to the effective utilization of these new devices for state estimation.

The idea of using direct phasor measurements for system monitoring applications including the specific case of state estimation is not new. Earlier work done by Phadke and his co-workers [1-2] introduces the use of PMUs for such applications. This work is later extended to the investigation of optimal location of PMUs where each PMU is assumed to provide voltage and current measurements at its associated bus and all inci-

dent branches [3]. It is therefore possible to fully monitor the system by using relatively less number of PMUs than the number of system buses. This problem is solved by using a graph theoretic observability analysis and an optimization method based on Simulated Annealing in [3]. Possible loss or failure of PMUs is not considered in that study.

In this paper, a numerical formulation of the optimal PMU placement problem will be presented. Preliminary results, which do not account for the loss of PMUs are presented in [4] earlier. This formulation leads to a solution based on integer programming and also facilitates analysis of network observability. Furthermore, it is general enough to account for loss of single PMUs, existence of zero and non-zero power injections and power flow measurements. Using the measurement design found by this method, the paper investigates the performance of linear estimators that exclusively use PMUs and describes detection and identification of failed PMUs by using the residual based bad data processing methods.

2 STATE ESTIMATION USING PHASOR MEASUREMENTS

2.1 State Estimation

Measurements that are telemetered from the substations are processed at the control centers by the state estimator. State estimator provides the optimal estimate of the system state based on the received measurements and the knowledge of the network model. Measurements may include the following:

- Power injections (real/reactive),
- Power flows (real/reactive),
- Bus voltage magnitude,
- Line current magnitude,
- Current injection magnitude.

PMUs provide two other types of measurements, namely bus voltage phasors and branch current phasors. Depending on the type of PMUs used the number of channels used for measuring voltage and current phasors will vary. In this study, it is assumed that each PMU has enough channels to record the bus voltage phasor at its associated bus and current phasors along all branches that are incident to this bus.

State estimation can be formulated as an optimization problem and solved using an appropriate numerical method. A common choice for the objective function is

the weighted sum of the measurement residual squares, which leads to the well known weighted least squares (WLS) state estimation solution. Formulation and solution methods for WLS state estimation when using the above-itemized conventional measurements are well documented in the literature and can be found for instance in [5]. Incorporating phasor measurements to an existing state estimator will require augmenting various arrays such as the measurement vector and the measurement Jacobian while not affecting the state vector. In that sense, the required modifications are not substantial and the overall problem formulation does not change significantly. On the other hand, if enough PMUs exist to make the entire system observable based exclusively on PMU measurements, then the state estimation problem can be formulated in a slightly simpler manner. In this case, the relation between the measured phasors and the system states will become linear yielding the following linear measurement model:

$$z = H \cdot x + e \quad (1)$$

where:

z : is the measurement vector containing the real and imaginary parts of the measured voltage and current phasors.

H : is the measurement Jacobian, which is constant and a function of the network model parameters only.

x : is the state vector containing the real and imaginary parts of bus voltage phasors.

e : is the measurement error vector.

This measurement model will lead to a linear state estimator, which will be given by the following equation:

$$\hat{x} = G^{-1} \cdot H^T \cdot R^{-1} \cdot z \quad (2)$$

where:

\hat{x} : is the estimated system state.

$G = H^T \cdot R^{-1} \cdot H$: is the constant gain matrix.

$R = E\{e \cdot e^T\}$: is the diagonal error covariance matrix.

2.2 Bad Data Processing

Note that several measurements will be associated with a single PMU in the measurement vector, z . In case of an error or failure of a PMU, this will contaminate all measurements provided by that PMU. Bad data detection and identification schemes typically process individual measurements and therefore they need to be used repeatedly on the affected measurements of the PMU in order to identify the faulty PMU. This is accomplished by first applying the largest normalized residual test to the measurements and then eliminating bad measurements one at a time in a cyclic manner. Due to the interactive nature of the measurements associated with a single PMU, they are vulnerable to error masking and possible misidentification of bad data. Fortunately, this occurs when errors are conforming which is typically the case if there are topology errors.

3 PLACEMENT OF PHASOR MEASUREMENTS

The objective of PMU placement is to make the entire system observable using a minimum number of PMUs. This objective will be slightly modified later in section 3.3 to account for loss of single PMUs. One of the assumptions about the considered PMUs is that each PMU has enough channels to measure bus voltage and all incident branch current phasors at a given bus.

Discrete nature of the problem naturally results in definition of a vector X of binary (0/1) decision variables, x_i as given below:

$$x_i = \begin{cases} 1 & \text{if a PMU is installed at bus } i \\ 0 & \text{otherwise} \end{cases} \quad (3)$$

Inner product of this binary vector and a vector containing corresponding installation costs of these PMUs, will be defined as the objective function of the optimization problem. Constraints will be added in order to ensure full network observability while minimizing the total installation cost of the PMUs. For an n -bus system, this optimization problem takes the following form:

$$\begin{aligned} & \text{minimize} && \sum_i^n w_i \cdot x_i \\ & \text{subject to} && f(X) \geq \hat{1} \end{aligned} \quad (4)$$

where:

w_i : is the installation cost of the PMU at bus i .

$f(X)$: is a vector function representing the constraints. Its entries are non-zero if the corresponding bus voltage is solvable using the given measurement set and zero otherwise.

$\hat{1}$: is a vector whose entries are all equal to 1.

Proper definition of the constraint vector function, $f(X)$ is the key to the presented formulation. Depending on the type of measurement system, this definition will change, while the objective function will remain the same. In order to simplify the description of the constraint function, it will be given using a small tutorial example containing 7 buses. Three cases will be discussed, where the existing system has:

- No measurements at all and no zero injections,
- Zero and nonzero power injections,
- Power injections and power flows.

Network diagram for the 7-bus example system is shown in Figure 1. Initially, for case 1, both of the conventional measurements, namely the power injection measurement at bus 3 (dot shown next to bus 3) and the power flow measurement on line 1-2 (solid square shown on line 1-2) will be ignored. They will be gradually taken into account in cases 2 and 3.

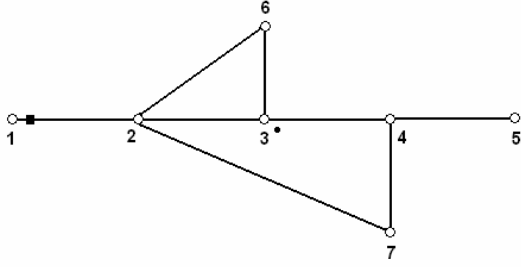

Figure 1: Network diagram for the 7-bus system

3.1 Case 1: A system, which has no conventional measurements and/or zero injections

Since it is assumed that a given PMU will provide phasors for the currents along branches that connect this bus to all its neighbors, once a bus is assigned a PMU, phasor voltages at all of its neighbors will be assumed to be known or solvable. An easy way to determine all such solvable buses is by using the binary connectivity matrix A as defined below:

$$A_{k,m} = \begin{cases} 1 & \text{if } k = m \\ 1 & \text{if } k \text{ and } m \text{ are connected} \\ 0 & \text{if otherwise} \end{cases} \quad (5)$$

This yields the following matrix for the 7-bus system of Figure 1:

$$A = \begin{bmatrix} 1 & 1 & 0 & 0 & 0 & 0 & 0 \\ 1 & 1 & 1 & 0 & 0 & 1 & 1 \\ 0 & 1 & 1 & 1 & 0 & 1 & 0 \\ 0 & 0 & 1 & 1 & 1 & 0 & 1 \\ 0 & 0 & 0 & 1 & 1 & 0 & 0 \\ 0 & 1 & 1 & 0 & 0 & 1 & 0 \\ 0 & 1 & 0 & 1 & 0 & 0 & 1 \end{bmatrix} \quad (6)$$

Taking the product of this matrix and the binary decision vector X will provide the desired vector function. Elements of this vector function will be at least equal to one, if at least one neighbor of the corresponding bus is assigned a PMU. Hence, the constraint equations for the above example for this case will be formed as:

$$f(X) = A \cdot X = \begin{cases} f_1 = x_1 + x_2 & \geq 1 \\ f_2 = x_1 + x_2 + x_3 + x_6 + x_7 & \geq 1 \\ f_3 = x_2 + x_3 + x_4 + x_6 & \geq 1 \\ f_4 = x_3 + x_4 + x_5 + x_7 & \geq 1 \\ f_5 = x_4 + x_5 & \geq 1 \\ f_6 = x_2 + x_3 + x_6 & \geq 1 \\ f_7 = x_2 + x_4 + x_7 & \geq 1 \end{cases}$$

The operator “+” serves as the logical “OR” and the use of 1 in the right hand side of the inequality ensures

that at least one of the variables appearing in the sum will be non-zero. For example, consider the constraints associated with bus 1 and 2 as given below:

$$\begin{aligned} f_1 &= x_1 + x_2 \geq 1 \\ f_2 &= x_1 + x_2 + x_3 + x_6 + x_7 \geq 1 \end{aligned}$$

The first constraint $f_1 \geq 1$ implies that at least one PMU must be placed at either one of buses 1 or 2 (or both) in order to make bus 1 observable. Similarly, the second constraint $f_2 \geq 1$ indicates that at least one PMU should be installed at any one of the buses 1, 2, 3, 6, or 7 in order to make bus 2 observable.

3.2 Case 2: A system, which contains zero and non-zero injection measurements

In this case, the injection measurement at bus 3 will be taken into account when determining the PMU locations. Note that if the phasor voltages at any three out of four buses 2, 3, 4 and 6 are known, then the fourth one can be solved using the Kirchhoff’s Current Law applied at bus 3 where the net injected current is known. This observation allows a topology transformation where the bus, which has the injection measurement can be merged with any one of its neighbors. Injection measurements whether they are actual measurements or zero injections, are treated the same way.

A word of caution needs to be added here in that, if the optimal solution chooses the newly formed fictitious bus (merger of two actual buses) as a candidate bus, it may place one PMU on one of these two buses or two PMUs on both. In this paper, a topology analysis is applied to check the observability of the system once this happens. This also assures that the minimum number of PMUs will be placed.

Figure 2 shows the updated system diagram after the merger of buses 3 and 6 into a new bus 6’. The newly created branch 6’-4 reflects the original connection between buses 3 and 4. Binary connection matrix A for this case is given below:

$$A = \begin{bmatrix} 1 & 1 & 0 & 0 & 0 & 0 \\ 1 & 1 & 0 & 0 & 1 & 1 \\ 0 & 0 & 1 & 1 & 1 & 1 \\ 0 & 0 & 1 & 1 & 0 & 0 \\ 0 & 1 & 1 & 0 & 1 & 0 \\ 0 & 1 & 1 & 0 & 0 & 1 \end{bmatrix} \quad (7)$$

Hence, the constraints vector function will be given :

$$f(X) = \begin{cases} f_1 = x_1 + x_2 & \geq 1 \\ f_2 = x_1 + x_2 + x_{6'} + x_7 & \geq 1 \\ f_4 = x_4 + x_5 + x_{6'} + x_7 & \geq 1 \\ f_5 = x_4 + x_5 & \geq 1 \\ f_{6'} = x_2 + x_4 + x_{6'} & \geq 1 \\ f_7 = x_2 + x_4 + x_7 & \geq 1 \end{cases} \quad (8)$$

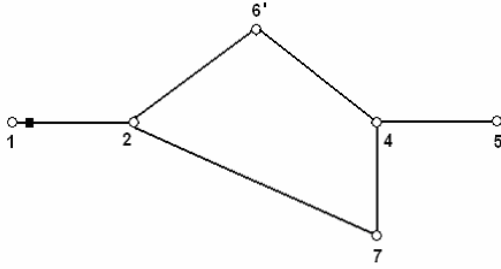

Figure 2: System diagram after the merger of buses 3 and 6.

3.3 Case 3: A system, which contains injections as well as flow measurements.

This case considers the most general situation where both injection and flow measurements may be present, but not enough to make the entire system observable. So, the objective is to place PMUs in order to merge the observable islands formed by the existing conventional measurements and render a fully observable system.

Flow measurement on branch 1-2 in the 7-bus example system will be used to illustrate the approach. Existence of this flow measurement will lead to the modification of the constraints for buses 1 and 2 accordingly. Modification follows the observation that having a flow measurement along a given branch allows the calculation of one of the terminal bus voltage phasors when the other one is known. Hence, the constraint equations associated with the terminal buses of the measured branch can be merged into a single constraint. In the case of the example system, the constraints for buses 1 and 2 are merged into a joint constraint as follows:

$$\begin{cases} f_1 = x_1 + x_2 & \geq 1 \\ f_2 = x_1 + x_2 + x_{6'} + x_7 & \geq 1 \end{cases} \Rightarrow$$

$$f_{1_new} = f_1 + f_2 = x_1 + x_2 + x_{6'} + x_7 \geq 1$$

Note that this new constraint ensures that if either one of the voltage phasors at buses 1 or 2 is observable, then the other one will also be observable. Applying this modification to the constraints the following set of final constraints will be obtained:

$$f(X) = \begin{cases} f_{1_new} = x_1 + x_2 + x_{6'} + x_7 & \geq 1 \\ f_4 = x_4 + x_5 + x_{6'} + x_7 & \geq 1 \\ f_5 = x_4 + x_5 & \geq 1 \\ f_{6'} = x_2 + x_6 + x_{6'} & \geq 1 \\ f_7 = x_2 + x_4 + x_7 & \geq 1 \end{cases}$$

3.4 Placement strategy against loss of a single PMU

So far it is assumed that those PMUs which are placed by the proposed method, will function perfectly. While PMUs are highly reliable, they are prone to failure just like any other measuring device. In order to guard against such unexpected failures of PMUs, the

above placement strategy is extended to account for single PMU loss. In this paper, this objective is achieved by choosing two independent PMU sets, a primary set and a backup set, each of which can make the system observable on its own. If any PMU is lost, the other set of PMUs will guarantee the observability of the system.

The primary set of PMUs is chosen by building the constraint functions according to the procedures described in subsections above and solving the integer-programming problem. The backup set is chosen by removing all the x_i terms in the constraint functions, where bus i is in the primary set, in order to avoid picking up the same bus which appears in primary set. Then the integer-programming problem is solved to obtain the backup set.

4 SIMULATION RESULTS

Simulations are carried out on the IEEE 14-bus, IEEE 57-bus and IEEE 118-bus systems.

4.1 Case 1.

Any existing injection measurements will reduce the required number of PMUs to make the system fully observable. Zero injection buses are particularly helpful since injection measurements at these buses are freely available. In case 1, results are presented to show the savings achieved on the number of PMUs when zero injections are taken into account. Two groups of simulations are carried out on the three test systems, which are assumed to have no flow measurements. Loss of PMUs is not considered in this case. In the first group of simulations, zero injections are simply ignored while in the second group, they are used as existing measurements. Comparative simulation results are shown in Table 1. Having zero injections will reduce the number of required PMUs as can be seen from these results.

SYSTEMS	NO. OF ZERO INJECTIONS	REQUIRED NUMBER OF PMUS	
		IGNORING ZERO INJECTIONS	USING ZERO INJECTIONS
14-BUS	1	4	3
57-BUS	15	17	12
118-BUS	10	32	29

Table 1: Results with and without considering zero injections

4.2 Case 2.

Any measurement including the PMU measurements are vulnerable to errors. In order to be able to detect PMU errors, none of the PMUs should be critical. This is equivalent to having a measurement system that maintains observability if any single PMU is lost. In this case, simulations of case 1 are repeated by accounting for loss of single PMUs as described in section 3.4. Primary and backup locations are found and combined

results are shown in Table 2. Comparing Tables 1 and 2 indicates that the required number of PMUs will double when the loss of single PMUs is taken into account.

SYSTEMS	NO. OF ZERO INJECTIONS	REQUIRED NUMBER OF PMUS	
		IGNORING ZERO INJECTIONS	USING ZERO INJECTIONS
14-BUS	1	9	7
57-BUS	15	35	26
118-BUS	10	72	66

Table 2: Results considering loss of single PMUs

4.3 Case 3.

In this case the effect of existing flow measurements on the required number of PMUs is investigated. Simulations are carried out using IEEE 118-bus system. Three sets of flow measurements (P and Q) containing 5 flow measurements each, are added to the system one set at a time. The locations of these flow measurements in the system are shown in Table 3.

As given in Table 4, the required number of PMUs is reduced from 29 to 21. As expected, having conventional measurements reduces the number of required PMUs to make the entire system observable.

MEAS. SET NO.	FLOW MEASUREMENTS IN THE SET				
1	1-2	21-20	21-22	17-113	86-87
2	41-42	43-44	46-48	53-52	53-54
3	90-89	90-91	91-92	101-100	101-102

Table 3: Locations of flow measurements used for case 3.

SYSTEM	FLOW MEASUREMENT SET	REQUIRED NUMBER OF PMUS
IEEE 118-BUS	NONE	29
	1	26
	1 AND 2	23
	1, 2 AND 3	21

Table 4: Simulation results for case 3.

4.4 Linear State Estimation using PMUs

As explained in section 2.1 state estimation problem becomes linear when there are sufficient PMU measurements to make the system observable. In this case, the performance of the linear state estimator, which uses only PMU measurements, is evaluated by simulations. Due to space limitations PMU locations are shown only for the 14-bus system in Figure 3. Computation times, the number of PMUs and state variables are given for different size systems in Table 5. It is noted that, in order to obtain a linear estimator, zero injections or any other type of conventional measurements are not used in this case.

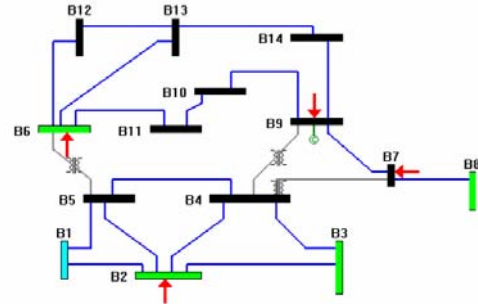

Figure 3: PMU locations for the 14 bus system (ignoring zero injections).

System	No of States	No of PMUs	CPU time (sec)
14	27	4	0.131
30	59	10	0.341
57	113	17	0.611
118	235	32	0.892

Table 5: CPU times for the linear state estimator.

These same test systems are then used to simulate bad PMU cases. Bad PMU detection and identification requires local redundancy in the vicinity of the bad PMU. This is accomplished by adding 2 extra PMUs at buses 10 and 11 for the 14-bus system and 1 PMU at bus 39 for the 118-bus system.

A bad PMU is simulated by introducing errors to all measurements provided by the same PMU. Denoting voltage phasor components as $V=E+jF$ and current phasor components as $I=C+jD$, the following measurements are simulated as bad data:

For the 14-bus system: $V(11)$, $I(11,6)$, $I(11,10)$

For the 118-bus system: $V(39)$, $I(39,37)$, $I(39,40)$.

Bad data processing is carried out using the cyclic application of the largest normalized residual (R_n) test as discussed in section 2.2 above. Test results for both systems are shown in Tables 6 and 7.

Bad data cycle	Sorted Normalized Residuals			
	1 st	2 nd	3 rd	4 th
Meas/ R_n	E (11) / 462.52	C (11,6) / 24.31	C (11,10) / 10.12	C (7,9) / 1.87
	E (6) / 98.77	C (6,11) / 16.17	C (10,11) / 8.15	C (9,7) / 1.58
	E (2) / 92.45	C (11,10) / 15.37	C (6,11) / 3.36	C (2,5) / 1.27
Eliminated meas.	V (11)	I (11,6)	I (11,10)	No More Bad data

Table 6: Bad data identification cycles for 14-bus system with a bad PMU at bus 11.

Bad components of voltage and current phasors are correctly identified and eliminated thanks to locally redundant measurement configurations for both cases. As discussed in section 3.4, it is possible to guarantee bad PMU detection and identification by making sure that none of the PMUs are critical. This can be achieved by the measurement design proposed in section 3.4. Cost associated with such a design versus the benefits of bad PMU detection capability can be evaluated.

Bad data cycle	Sorted Normalized Residuals			
	1 st	2 nd	3 rd	4 th
Meas/ R _n	E (39) / 388.84	C(39,37) / 217.82	C (39,40) / 105.18	E (68) / 2.41
	C(39,37) / 216.67	C (39,40) / 131.52	C (40,39) / 91.56	E (34) / 2.02
	E (37) / 137.24	C(37,39) / 106.36	C (37,39) / 27.14	E (80) / 1.98
Eliminated meas.	V (39)	I (39,37)	I (39,40)	No More Bad Data

Table 7: Bad data identification cycles for 118-bus system with a bad PMU at bus 39.

5 CONCLUSIONS

This paper is concerned with two issues related to the phasor measurement units. The first issue is proper placement of these devices for a given budget. This issue is addressed via a 0-1 integer programming method, where injections and power flow measurements

are also considered. As a further consideration, loss of single PMUs is also taken into account to minimize the vulnerability of state estimation to PMU failures. Once placed, the utilization of PMUs for state estimation is investigated. Potential benefits of incorporating these devices into the existing measurement set, both from the point of view of bad data elimination as well as computational performance, are identified and illustrated by simulated examples.

REFERENCES

- [1] A. G. Phadke, "Synchronized phasor measurements in power systems", IEEE Computer Applications in Power, Vol. 6, Issue 2, pp. 10-15, April 1993.
- [2] A. G. Phadke, J. S. Thorp, and K. J. Karimi, "State Estimation with Phasor Measurements", IEEE Transactions on Power Systems, Vol. 1, No. 1, pp. 233-241, February 1986.
- [3] T. L. Baldwin, L. Mili, M. B. Boisen, and R. Adapa, "Power System Observability With Minimal Phasor Measurement Placement", IEEE Transactions on Power Systems, Vol. 8, No. 2, pp. 707-715, May 1993.
- [4] Bei Xu and A. Abur, "Observability Analysis and Measurement Placement for Systems with PMUs", Proceedings of the IEEE PES Power Systems Conference and Exposition, October 10-12, 2004, New York, NY.
- [5] A. Abur and A.G. Exposito, Power System State Estimation, Marcel Dekker, 2004.