

INTEGRATION OF STOCHASTIC GENERATION IN POWER SYSTEMS

G.Papaefthymiou, P.H.Schavemaker, L. van der Sluis
Electrical Power Systems, Delft University of Technology
Delft, The Netherlands
g.papaefthymiou@ewi.tudelft.nl

W.L. Kling
Electrical Power Systems, Delft University of Technology
Electrical Power Systems, Eindhoven University of Technology
Delft, Eindhoven, The Netherlands

D.Kurowicka, R.M.Cooke
Institute for Applied Mathematics, Delft University of Technology
Delft, The Netherlands

Abstract - Stochastic generation, i.e. electrical power production by an uncontrolled primary energy source, is expected to play an important role in future power systems. A new power system structure is created due to the large-scale implementation of this small-scale, distributed, non-dispatchable generation; the 'horizontally operated' system. Modelling methodologies that can deal with the operational uncertainty introduced by these power units should be used for analyzing the impact of this generation to the system. In this contribution, the principles for this modelling are presented, based on the decoupling of the single stochastic generator behavior (marginal distribution-stochastic unit capacity) from the concurrent behavior of the stochastic generators (stochastic dependence structure-stochastic system dispatch). Subsequently, the *Stochastic Bounds Methodology* is applied to model the extreme power contribution of the stochastic generation to the system, based on two new sampling concepts (*comonotonicity-countermonotonicity*). The application of this methodology to the power system leads to the definition of clusters of positively correlated stochastic generators and the combination of different clusters based on the sampling concepts. The stochastic decomposition and clustering concepts presented in this contribution give the basis for the application of new uncertainty analysis techniques, for the modelling of the stochastic generation in power systems.

Keywords - Stochastic power generation, distributed generation, steady-state analysis, uncertainty analysis, Monte Carlo Simulation, risk management

1 INTRODUCTION

THE power system industry undergoes a radical change: the transition from the 'vertical' to a 'horizontally-operated' power system. One of the major changes brought by this new structure, is the incorporation of higher levels of non-dispatchable, stochastic generation in the system. This necessitates the development of new modelling and design methodologies in order to

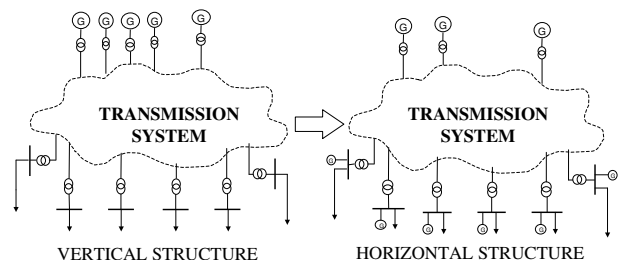

Figure 1: Vertical to Horizontal Power Systems Transformation

analyze the system operation under the uncertainty introduced by this abatement in generation dispatchability.

In the traditional, 'vertical' structure, electrical energy is produced (the primary energy source is converted into electricity) by a small number of large power plants. This energy is transported to the geographically remote consumption points through extensive transmission and distribution networks. The type of primary energy source used (fossil fuels, nuclear energy, hydro-power, etc.) permits sophisticated control of the power output of these large power plants and robust system operation. The transition to the new power system structure is stimulated by special socio-economic factors, namely the promotion of the use of renewable energy sources as primary energy movers and the liberalization of the energy market.

A new generation concept is responsible for this transition, the *Distributed Generation (DG)*. According to this generation scheme, the systems of the future obtain a non-centralized, horizontal structure (Fig. 1) [1]. In particular, electrical energy generation takes place in a large number of small- to medium-scale, geographically distributed power plants. These plants can either be small-scale customer-owned conventional generators, or stochastic generators, i.e. power plants that make use of a non-controlled prime mover, e.g. renewable energy sources, combined heat-power plants etc. [2]. The operation of these units introduces generation uncertainty in the system, in addition to the uncertainty of the consumption.

2 'HORIZONTALLY-OPERATED' POWER SYSTEM

In a simplified representation, a power system can be considered to comprise four entities, that interact via the transmission and the distribution systems, three energy generating ones (generation system) and one energy consuming (load), as shown in Fig.2. The generation system consists of the following entities: large thermo-electric power plants that use fossil fuels or nuclear energy as prime mover or large hydro-electric power plants (*Centralised Generation - CG*), small-scale conventional power plants (*Dispatchable Technology DG - DT/DG*) and power plants that make use of non-dispatchable technologies of electrical power generation, like renewables (wind, solar, run-of-the-river hydro, wave energy, etc.) or combined heat and power plants, cogeneration, etc. (*non-Dispatchable Technology DG - NDT/DG*). According to this representation, one can recognize two non-dispatchable (load and NDT/DG) and two dispatchable system entities (CG and DT/DG). The output of the non-dispatchable entities is defined by external factors, such as the customer behavior in the case of the load and the stochastic prime mover activity in the case of NDT/DG. During the system operation, the dispatchable generation entities adapt to the variations of the non-dispatchable ones, so that the necessary equalization between produced and consumed power in the system is achieved, taking into account restrictions set by the transmission and distribution networks.

System analysis based on this scheme involves two modelling activities: uncertainty analysis of the non-dispatchable entities (load and NDT/DG) and economic dispatch of the dispatchable units [3]. These two problems are in principle independent; the output of the loads and NDT/DG units is mainly defined by the activity of the uncontrolled prime mover or the customer, while the energy market mechanisms define the power output of the conventional units. Of course, NDT/DG units operate under the same market environment; however, due to the behavior of the prime energy mover, their control is focused to maximize their energy yield. On the other hand, both conventional and stochastic generating units are subject to random unavailability, due to equipment failures or forced outages [4], which can be incorporated in the system uncertainty analysis.

3 UNCERTAINTY IN POWER SYSTEMS

3.1 Computational Methods for Uncertainty Modelling

A power system is predominantly in steady-state operation or in a state that can be regarded with sufficient accuracy as steady state. Although in practice there are always small load/generation changes, switching actions and other transients occurring so that in strict mathematical sense most of the variables are varying in time, these variations are most of the time so small, that the use of an algebraic, i.e. non time-varying, model of the power system is justified. Using this algebraic model (steady-state

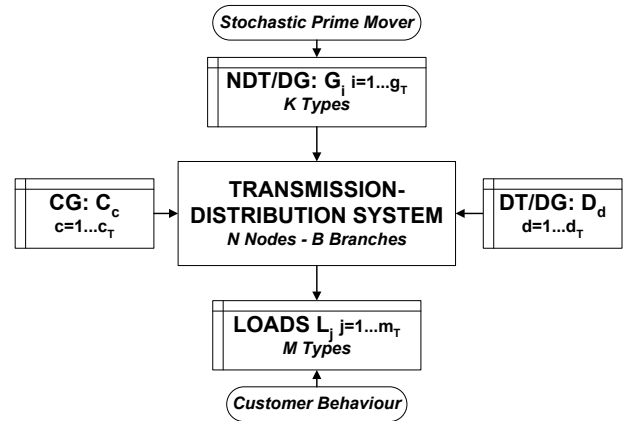

Figure 2: Power System Schematic Representation

model), one can assign the corresponding system states (nodal voltage angles and magnitudes) and outputs (active and reactive power flow at each system branch) to a set of system inputs by solving a system of non-linear static (non time-varying) equations [5]. This is a deterministic calculation: for a specific set of inputs the respective outputs are computed.

By using the deterministic system models, one can calculate the system behavior for a 'snapshot' of operation, a specific instant in time, in other words a specific 'state of the world'. For operational planning however, the system output for all instants should be assessed, i.e. the system response to all the different combinations of the inputs. This requires a prohibitive amount of calculations. For a network of N loads/stochastic generators, each taking k different values, a total of k^N deterministic load flow calculations have to be performed. In order to solve this problem, starting from the early seventies, different computational methodologies for power systems uncertainty analysis were introduced and a large number of research papers was published [6]. Three general approaches can be recognized, the *Probabilistic Analysis* [7], the *Fuzzy Arithmetic (Possibilistic) Analysis* [8], [9] and the *Interval Arithmetic Analysis* [10]. In this contribution, the probabilistic approach will be used for the system steady-state analysis. Based on the system steady-state uncertainty analysis, the incorporation of uncertainty in other system studies can be performed [11].

3.2 Probabilistic Power System Analysis

According to the probabilistic approach, the input variables are converted to *random variables (r.v.)* with known distributions (*probability density functions (pdfs)*) [12]. The results are not fixed numbers, but pdfs, showing the possible range of the resulting quantities and the corresponding probability of each value to occur. In general, there are two main methodologies for the solution according to the probabilistic approach: the analytical formulation and the stochastic simulations (Monte Carlo Simulation technique - MCS). In cases of non-correlated inputs, the analytical methods perform very well. The analytical methods proposed in the literature for the treatment of

correlated inputs are restricted to linear [13], [14], [15] or second order dependence, i.e. the statistical dependence among the variables is assumed to be captured in their second order moments [16], [17]. However, as mentioned in [15], in situations that involve complicated relations between some or all the input r.v., the MCS technique appears to be the only option.

The Monte Carlo Simulation (MCS) is a numerical simulation procedure applied to problems involving random variables [12], [18]. The simulation process is repeated by using in each simulation a particular set of values generated in accordance with the corresponding probability distributions. A sample from a MCS is similar to a sample of experimental observations. Therefore, the results can be treated statistically. The MCS method is based on a random sampling procedure, and this makes the generation of random numbers the basic point of this method. There are three key phases in an MCS. The first is to generate random numbers from the given probability distributions. The next step is a deterministic one, where the mathematical model is solved to obtain the quantities of interest. Finally, the first two steps are repeated a finite number of times, and a statistical analysis of the results is performed. This method appears to offer significant advantages compared to analytical methods, since the basic computational part (i.e. the second step) is deterministic and there is no need to simplify the mathematical models for the application of the method. But, for obtaining proper results, the sampling procedure has to be repeated many times and this makes the method computationally extensive.

In the case of 'horizontally-operated' power systems, the dimension of the stochastic model is very large and the dependencies between the inputs may be complex and difficult to be incorporated in the system analysis. Since stochastic generation is expected to cover an increasing part of the energy production, there is a need for new analyzing methodologies, that will cope with this generation uncertainty.

4 MODELLING OF STOCHASTIC GENERATION IN POWER SYSTEMS

4.1 Definitions - Problem Formulation

A stochastic generator is an energy conversion system that converts an uncontrollable primary energy source (wind-, solar-, hydro-, wave- energy, waste heat, etc.) into electrical power and feeds it into the power system. The power output of a stochastic generator is defined by two factors:

1. *Stochastic Prime Mover*: the type of primary energy source used for electrical power generation. Due to their geographical dispersion, the stochastic behavior of similar prime movers differs at different sites in a system. According to the probabilistic approach, the prime mover activity is modelled as a random variable (r.v.) following a specific statistical distribution.

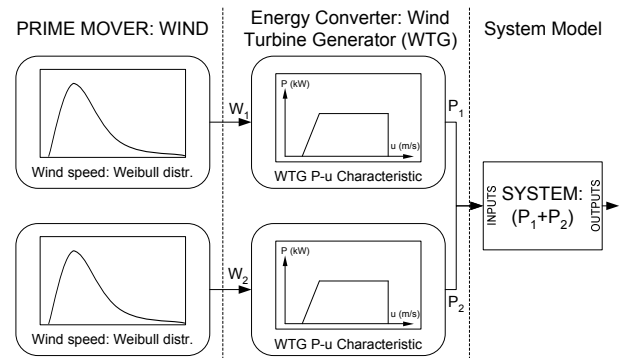

Figure 3: Stochastic Generation Modelling Procedure (Case of WTGs)

2. *Energy Conversion System*: according to the converter technology, the power output of the generator for each input value of the prime mover can be defined by a deterministic relationship. According to the system analysis to be performed (steady-state, dynamic/transient stability, etc.), an appropriate converter model should be utilized [19].

These two factors determine the power output of a single stochastic generator. However, more information is necessary for the definition of the joint contribution of the stochastic generators to the system; the coupling between the respective prime movers should be taken into account, i.e. the behavior of each prime mover respective to the other. In particular, the power output of stochastic generators situated in a small geographic area show similar fluctuations due to their mutual dependence on the same prime mover, which is not the case for stochastic generators situated in remote areas. This is the most cumbersome problem in the modelling procedure which is often underestimated in power system modelling. In order to depict these issues, the most simple example is chosen: the modelling of the aggregated power output of two stochastic generators (*Wind Turbine Generators - WTG*) in a power system.

4.2 Example: Modelling of Two-Stochastic Generators

In the case of wind power, the stochastic prime mover is the wind activity and the energy conversion system is the wind turbine generator. Let WTG_1 and WTG_2 be two wind turbine generators (WTGs) situated in two distinct sites in a power system. We want to calculate their joint power contribution to the system, i.e. their aggregated power output. For this purpose, the steps defined in the previous paragraph will be followed. The modelling procedure is depicted in Fig. 3.

For the definition of the power output of each generator, the wind speed distribution at each generator site is used for the modelling of the prime mover: W_1 for site 1 and W_2 for site 2. As is generally known, they follow a Weibull distribution [20], with the parameters A and k : $A_1 = 8.39$, $k_1 = 2.1$, and $A_2 = 6.34$, $k_2 = 2.02$. For the energy conversion system model, the WTG power - wind speed characteristic is used. In this particular case, two pitch-controlled WTGs of 1MW nominal power are con-

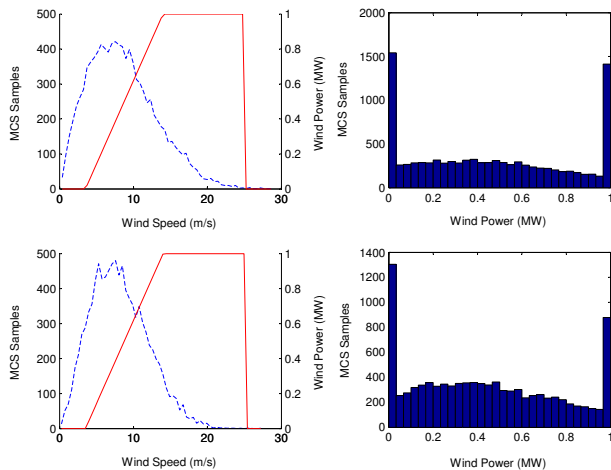

Figure 4: Wind Speed Distributions, WTG Wind Speed - Power Characteristic, WTG Power Output Distributions for the WTGs

sidered, with the cut-in, nominal and cut-out wind speeds equal to 3, 13 and 25 m/s respectively. In order to obtain the WTG power output distributions P_1 and P_2 , this non-monotonic transformation is applied to the wind speed distributions (Fig. 4). The obtained WTG power distributions are propagated through the system model, which is in this case defined as the sum of the WTGs outputs, to obtain the respective result.

As mentioned, the data presented so far are not enough for setting up this simulation. The coupling between the prime movers should also be taken into account, i.e. the wind speed on one site conditional to the other. A general practice in power system modelling is to consider the r.v. W_1 and W_2 to be independent. This may however be a non-realistic assumption. In practice, especially in cases of WTGs situated in a relatively small geographic area, where similar weather conditions prevail, the wind activity in the two sites is expected to be positively correlated. The notion of independence implies that knowing the wind speed in one location does not change our belief about the wind speed in the other location, which contradicts reality; when a high (low) wind speed occurs in site A, most likely a high (low) wind speed occurs in site B. In order to depict the influence of the dependence assumption on the contribution of the stochastic generators to the system, two different simulations were considered: in the first simulation the wind speed r.v. W_1 and W_2 are considered independent, while in the second one they are considered to be totally correlated. Totally correlated or comonotonic r.v. are the ones that vary in the same way, meaning that when the one increases (decreases) the other increases (decreases) too.

For the system analysis, two 10000-sample Monte Carlo Simulations (MCS) were used, for the two dependence scenarios. For the modelling of the prime mover activity, the Weibull distributions presented in Fig. 3 were used in both simulations. In Fig. 4, the simulation results for the wind speed and the WTG power output distributions are presented. The obtained power distributions are highly non-normal, presenting a concentration of prob-

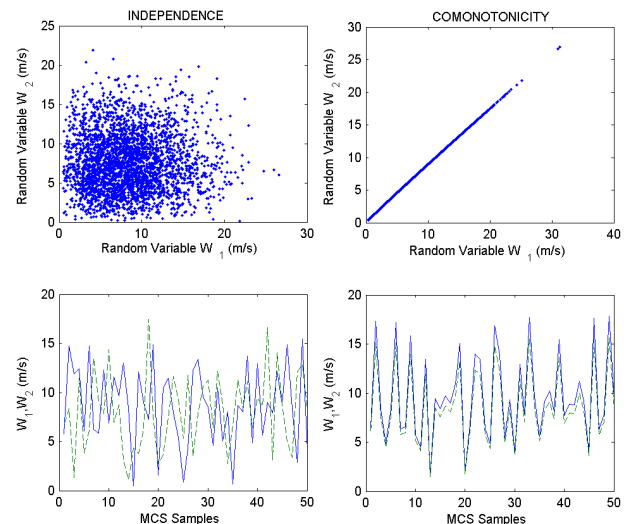

Figure 5: Scatter-plots and time-series data for the two dependence scenarios

ability in the zero and nominal output power. This is due to the effect of the non-monotonic WTG characteristic [21]; for wind speed values lower than the cut-in and higher than the cut-out wind speed, the generated power equals zero, while for wind speed values between nominal and cut-out, the generated power equals its nominal value [19].

In Fig. 5 the simulation results concerning the concurrent behavior of the prime mover are presented. In the upper graphs, the scatter plots for the two dependence scenarios are presented, while in the lower ones, a fragment of the generated time-series sequences is shown. The spreading of the points in the independence case is high. In the comonotonic case, the points are linearly correlated; high (low) values of the one r.v. are combined to high (low) values of the other. The generated sequences depict this issue: in the independence case the sequences vary randomly, while in the comonotonic case they follow the same variations.

These two different ways of combining the outputs of the generators strongly affect their aggregated power output. In particular, in the case of independence, the power output distribution is more 'smooth', since the extremes of one generator can be combined with all power outputs of the other. This is not the issue in the comonotonic situation, where extreme power outputs for one generator imply extremes for the other too. The simulation results depict exactly this point. As shown in Fig. 6, the aggregated power distributions are very different, where the independence case results in a much more 'moderate' distribution. Although it is a general practice to underestimate the impact of the dependence structure in the power system stochastic modelling by assuming independence, the results of this simple example show that this is a fallacy. In the case that the outputs of the stochastic generators are coupled due to their common dependence on the prime mover, for example in the case of stochastic generators situated in a relatively small geographic area, it should be expected that we move towards the right graph

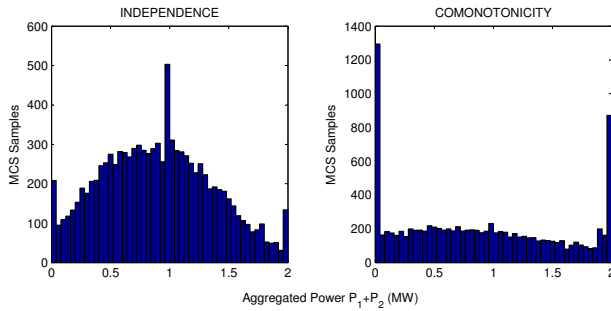

Figure 6: Aggregated Power Output from two Stochastic Generators

MEAN	P_1 (MW)	P_2 (MW)	$P_1 + P_2$ (MW)
Independ.	0.461	0.439	0.899
Comon.	0.453	0.436	0.899
ST. DEV.	P_1 (MW)	P_2 (MW)	$P_1 + P_2$ (MW)
Independ.	0.343	0.316	0.468
Comon.	0.343	0.314	0.653

Table 1: Power Output Mean Values and Standard Deviations

in Fig. 6. An analysis based on independence will underestimate the effect of the stochastic generation to the system and will give a false quantification of system risk.

In table 1, the mean values and standard deviations for the WTGs single and aggregated power outputs are shown. Concerning the power distributions for each WTG, the mean values and standard deviations are the same for both dependence scenarios, due to the use of the same prime mover distributions. Concerning the aggregated power output, the obtained distributions have the same mean but different standard deviations. As known from probability theory, the expected value of a sum of r.v. is independent of the dependence structure and equals the sum of the expected values of the r.v., as confirmed by the simulation results (table 1). This however doesn't hold for the standard deviation; in the case of total correlation, its value is much higher. Thus, different aggregated power output distributions around the same central point are obtained.

4.3 Modelling Principles of Stochastic Generation

This simple exercise shows the modelling principles and potential problems concerning the implementation of stochastic generation in power systems. The modelling process involves three steps:

1. Stochastic representation of the prime mover in each generation site
2. Calculation of power distributions by application of the energy conversion function
3. Combination of the power output of each generator in order to obtain the total stochastic power contribution to the system.

The first two steps concern the single-generator stochastic behavior, while the third one the information about their combined contribution to the system. Modelling of

the third factor is the most cumbersome part in the modelling procedure, due to data unavailability or modelling complexity. For large-scale integration of stochastic generation in the system, the mentioned problems are magnified. In this case, one has to define the joint power contribution of a large number (thousands) of stochastic generators situated in a large geographic area with different prime movers and different converter technologies.

4.4 System Stochastic Model

In the procedure presented in the previous paragraph, a modelling issue is advanced: the decoupling of the power output of each generator from the joint behavior of the generators in the system. This is the basic principle for the stochastic modelling approach proposed here.

The stochastic modelling of the system leads to a multivariate uncertainty analysis problem which involves a large number of correlated random variables (stochastic generation/load). For the system stochastic modelling, the joint distribution over all the random inputs has to be defined. The approach advanced here involves splitting the modelling effort in two separate tasks [22]:

- model the one-dimensional marginal distributions
- model the stochastic dependence structure

The one-dimensional marginal distributions refer to the single output of the generator/load and are usually known by measurements. The stochastic dependence structure is either unknown, or is considered to be too cumbersome to be incorporated in the system analysis. New methodologies and new dependence concepts should be introduced for the better representation of the stochastic generation in the system. In the following analysis, two extreme dependence concepts will be introduced, corresponding to the cases of extreme positive and extreme negative dependence in the system (stochastic bounds). These concepts are very useful for the modelling of the stochastic generation.

5 EXTREME STOCHASTIC DEPENDENCE MODELLING: STOCHASTIC BOUNDS

Stochastic generators are energy conversion systems that convert uncontrolled primary energy into electrical power. The power outputs of stochastic generators situated in a relatively small geographic area that use the same generation technology are expected to be strongly coupled, i.e. their power outputs are expected to follow similar fluctuations. The same holds for the system loads; as is generally known, similar types of loads throughout the system show a similar stochastic behavior. Thus, the system comprises groups (clusters) of strongly positively correlated r.v.

In order to model the stochastic behavior of these r.v., one has to define this positive correlation between all the r.v. of the group, which is a very cumbersome procedure. However, there is another solution: instead of taking this dependence structure, one can use another, more extreme

dependence structure, which is easier to model. This corresponds to an analysis based on a 'worst-case scenario'. The extreme dependence structures that can be used are two dependence concepts: *comonotonicity* and *countermonotonicity*. The theory behind these concepts is extensively presented in [23], [24], [25], while the application in power systems has been presented by the authors in a number of recent papers [21], [26], [27].

5.1 Stochastic Bounds Methodology

According to the *Stochastic Bounds Methodology* (SBM), all possible dependence structures for a number of positively correlated r.v. can be bounded between two extreme cases: independence (lower bound) and comonotonicity (upper bound). Comonotonicity is a dependence concept that refers to the case of extreme positive dependence between a number of r.v. It is noted that comonotonicity is a more general concept than perfect (linear) correlation, as it includes all cases of perfect positive non-linear dependence. Thus, perfect product moment correlation always implies comonotonicity, but not vice versa. Similarly, the extreme case of negative dependence between two r.v. can be modelled using the concept of countermonotonicity. A pair of r.v. is countermonotonic when they vary in an opposite way.

In the case of the r.v. $Y_i, i = 1, \dots, n$ the sampling based on these dependence concepts can be expressed as:

$$\text{Independent} : Y_i = F_{Y_i}^{-1}(U_i) \quad (1)$$

$$\text{Comonotonic} : Y_i = F_{Y_i}^{-1}(U) \quad (2)$$

$$\text{Countermon.} : Y_1 = F_{Y_1}^{-1}(U), Y_2 = F_{Y_2}^{-1}(1 - U) \quad (3)$$

where U_i s are independent uniform r.v. In the case of independence, different random generators are used for the sampling of each r.v., while in the case of comonotonicity and countermonotonicity, only one random generator is used for the stochastic modelling. These sampling concepts are illustrated in Fig. 7, for the case of two normal r.v. As can be seen, the produced comonotonic sequences follow the same variations, while the countermonotonic ones vary in an opposite fashion.

Taking the extremes of the dependence structure between a vector of r.v. has important implications for the properties of the sum of these r.v. [24], [25]. In particular, since the marginal distributions are the same, the different extreme dependence structures produce distributions for the sum of the r.v. with the same mean but different variances: minimum in the case of independence and maximum in the case of comonotonicity. In this case, a higher variance implies a distribution with a larger spread around the same central point, i.e. a higher probability of obtaining extreme values. Thus, in terms of risk assessment, comonotonicity provides the higher risk case (extreme distribution of the sum of these r.v.), while independence provides a minimum risk. Here, the

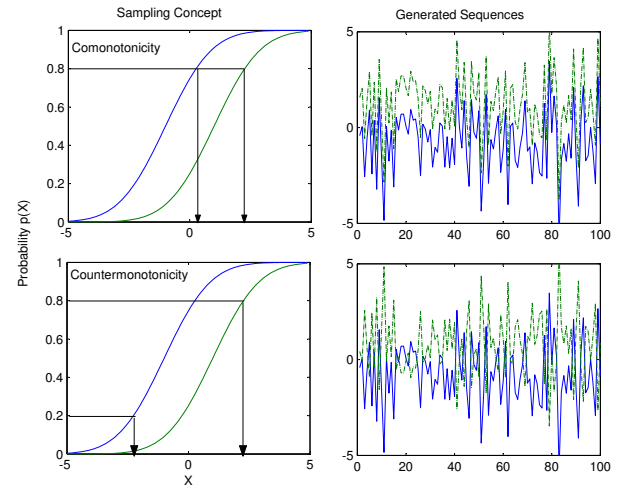

Figure 7: Comonotonic/Countermonotonic Sampling and Generated Sequences

fallacy concerning the use of the independence assumption for system analysis in cases of positively-dependent r.v. is underlined: such an analysis is based on the 'best case scenario'; according to SBM, every realistic dependence structure will induce a more severe impact to the system. This was illustrated also in the simple example concerning the aggregated power output from two WTGs in section 4. All the other dependence structures produce a sum whose variance (as well as other, more sophisticated, measures of dispersion) will lie in between those two bounds. Therefore, by using the extreme dependence concepts, one can define the stochastic bounds of the sum of the r.v.

In the case that the r.v. are strongly positively correlated, the comonotonic scenario can provide an easy method for the stochastic analysis of the system. In particular, instead of using the exact dependence structure between the r.v., the system designer can use the upper stochastic bound, knowing that it is not reality, but safe since this is the worst-case scenario. Therefore, clusters of positively correlated r.v. can be approximated by their comonotonic versions. In order to obtain the worst-case scenario, countermonotonic sampling should be used between stochastic generation and load clusters, due to the fact that in the system model the stochastic generation is subtracted from the loads [21]. Utilities often use a similar approach for estimating the stress to the system due to the incorporation of stochastic generation, by analyzing the system with the maximum (minimum) stochastic generation and minimum (maximum) load.

6 STUDY CASES

The application of the above-mentioned concepts in two study cases will be presented in the following sections; the case of a small distribution system and the case of a bulk power system.

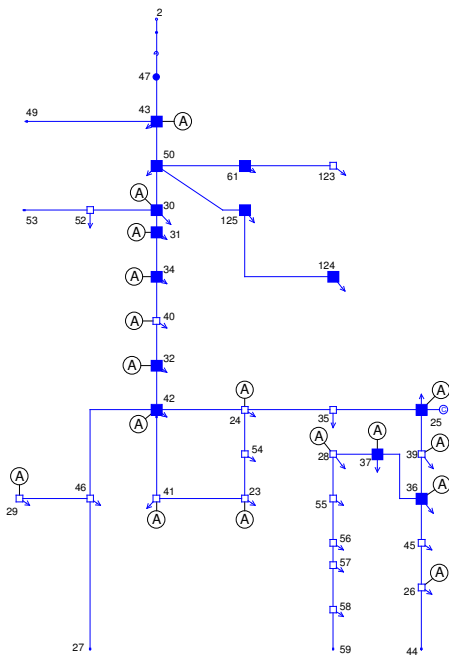

Figure 8: Study Case 1: 34-bus 38-branch Distribution System

6.1 Stochastic Generation in a Distribution System

The implementation of a large number of stochastic generators in a distribution system is considered, in particular the implementation of 17 WTGs in the distribution system depicted in Fig. 8.

The number of r.v. involved in the analysis is 54 in total: 17 WTGs and 37 loads. The WTGs are modelled based on the procedure presented in the two-WTG example and their marginal distributions are similar to the ones of Fig. 4. The loads are modelled as normal distributions. Three stochastic generation penetration levels were investigated in the simulation scenarios, according to the nominal power of the WTGs: (a) no generation, (b) each WTG has a nominal power of 0.25MW, (c) each WTG has a nominal power of 0.5MW. It is supposed that the stochastic generators do not contribute to the reactive power support of the system, therefore their reactive power output equals zero.

Due to the fact that the distribution system covers a small geographic area where the prime mover activity can be considered to be uniform and similar load types exist, two clusters of positively correlated r.v. can be recognized: the stochastic generation and the load cluster. Four different extreme dependence structures can be considered following this clustering procedure. One referring to the lower stochastic bound (scenario a: total independence between all loads and stochastic generators) and three upper stochastic bounds based on the combination of the comonotonic versions of the two inputs clusters: comonotonicity between load/stochastic generation (scenario b), countermonotonicity (scenario c) and independence between the clusters (scenario d). Scenario b implies that the stochastic generation acts as committed generation, following the load variations, which is not a real-

Mean Value				
Penetr. Level	scen a	scen b	scen c	scen d
-	0.9462	0.9461	0.9461	0.9461
17x0.25 (MW)	0.9658	0.9655	0.9655	0.9658
17x0.50 (MW)	0.9844	0.9841	0.9825	0.9835
Standard Deviation				
Penetr. Level	scen a	scen b	scen c	scen d
-	0.0015	0.0064	0.0063	0.0063
17x0.25 (MW)	0.0043	0.0102	0.0220	0.0171
17x0.50 (MW)	0.0078	0.0250	0.0357	0.0307

Table 2: Mean Values/Standard Deviation for Voltage at node 40

Mean Value				
Penetr. Level	scen a	scen b	scen c	scen d
-	3.4626	3.4645	3.4669	3.4675
17x0.25 (MW)	1.7797	1.8090	1.7890	1.7760
17x0.50 (MW)	0.1581	0.1749	0.2913	0.2144
Standard Deviation				
Penetr. Level	scen a	scen b	scen c	scen d
-	0.0866	0.3913	0.3874	0.3861
17x0.25 (MW)	0.3478	1.0191	1.7502	1.4270
17x0.50 (MW)	0.6592	2.3308	2.9817	2.6646

Table 3: Mean Values/Standard Deviation Power Flow Branch 47-43

istic consideration for wind power. However, this type of dependence may be met in the case of solar generation in areas that contain air-conditioning loads. Scenario c corresponds to the worst-case scenario, when the stochastic generation varies in the opposite way from the load and scenario d corresponds to stochastic generation that presents no interdependence with the load in the system.

For the stochastic analysis of the system, a 10000-sample MCS was used. A program was developed in MatLab and the simulation time was 10902 sec in a Pentium IV 2.4MHz machine. The program provides the voltage and power flow distributions for all the nodes and branches of the system and for all the different scenarios.

In tables 2 and 3, the simulation results for the mean value and standard deviation of the voltage distribution in node 40 and power flow distribution in branch 47-43 are presented. As mentioned, by keeping constant marginal distributions, different stochastic dependencies between the system inputs lead to different aggregated power distributions around the same mean, with the lower bound (independence) being the case of minimum spread and the upper bounds the cases of maximum spread. These distributions are propagated through the algebraic steady-state system model. The obtained results for all system nodes show that for the voltage distributions, the mean values are more or less the same for the different scenarios, while the standard deviations are minimum in the case of independence (lower bound) and maximum for the different upper bounds. Representative results for node 40 of the test system are presented in table 2.

In Fig. 9, the simulation results concerning the voltage distribution in node 40 are presented, while in Fig. 10 and Fig. 11, the results for the power flows in the branches between the nodes 39-25 and 47-43 for the different dependence scenarios are shown. In the case of

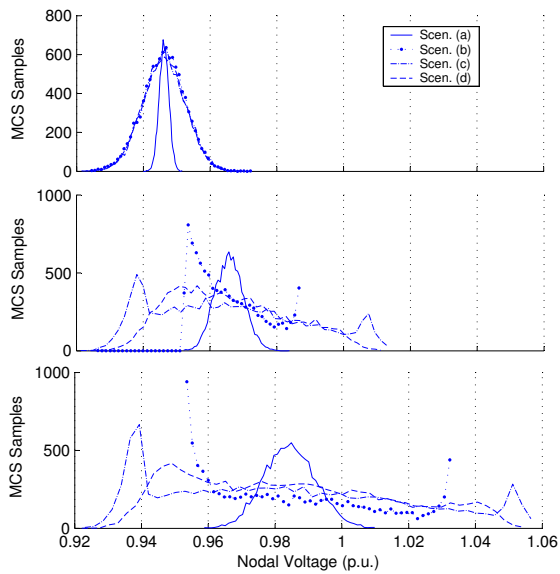

Figure 9: Voltage Distributions for Node 40, for three penetration levels of wind power

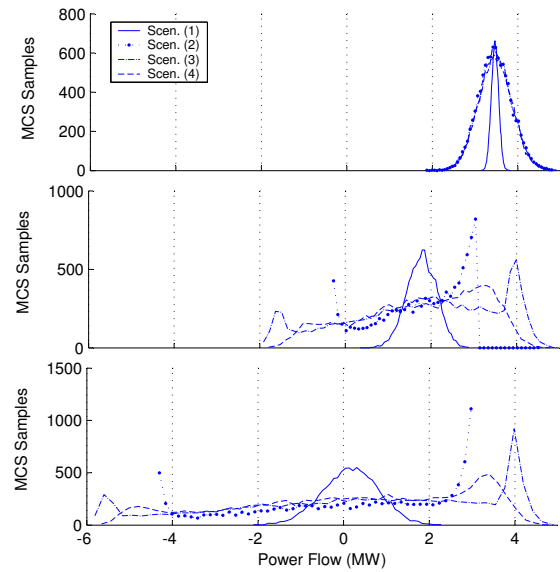

Figure 11: Power Flow Distributions for Branch 47-43, for three penetration levels of wind power

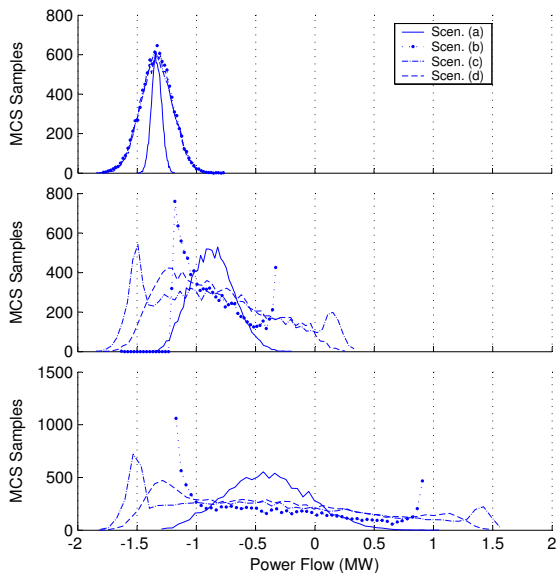

Figure 10: Power Flow Distributions for Branch 39-25, for three penetration levels of wind power

no generation, the distributions for the different upper bounds coincide, since they all correspond to the case of total correlation between the system loads. The upper bound scenarios provide distributions with a higher spread. This poses a higher risk for the system, either for voltage violations (Fig. 9) or for line overloading (Fig. 10 and Fig. 11). In all cases, scenario c (countermonotonicity between generation-load clusters), entails the highest risk. The methodology is very useful for the design of distribution systems, since the system designer can obtain insight in the worst-case scenario impact of the stochastic generation in the system, knowing that every real case will induce a lower stress to the system.

In Fig. 11, the power flow distributions for the branch 47-43 are presented. This is actually the power exchange between the distribution and the transmission system.

The distributions present a high spread, and high bidirectional power flows can be expected, especially in the case of positively-correlated stochastic generators. This graph visualizes the impact to the power system due to the implementation of stochastic generation. The distribution networks are transformed into active network clusters, exchanging power with the transmission system that acts as an energy buffer that interconnects the active distribution systems and the centralized generation.

A question that could arise is the following: how to model the joint contribution of a large number of such active distribution systems and how to obtain insight the behavior of a bulk power system?

6.2 Stochastic Generation in a Bulk Power System

In this study case, the impact of a large-scale implementation of stochastic generation in a bulk power system is considered. In particular, the large-scale implementation of stochastic generation in the underlying distribution systems at nodes 3, 4 and 5 of the test system presented in Fig. 12 is considered, by the connection of 45, 40 and 60 WTGs of 1MW nominal power in each distribution system respectively. More details can be found in [27].

The underlying distribution systems are represented as an aggregated load in parallel with an aggregated stochastic generator. According to the preceding analysis, the data for the prime mover activity (Weibull wind speed distributions) and aggregated load in each distribution system are considered to be known. These marginal distributions are kept constant while different simulations are performed for different extreme dependence scenarios based on the Stochastic Bounds Methodology. The application of the methodology involves the clustering of the positively correlated r.v. and the combination of the different clusters according to relative assumptions, as presented in the previous example.

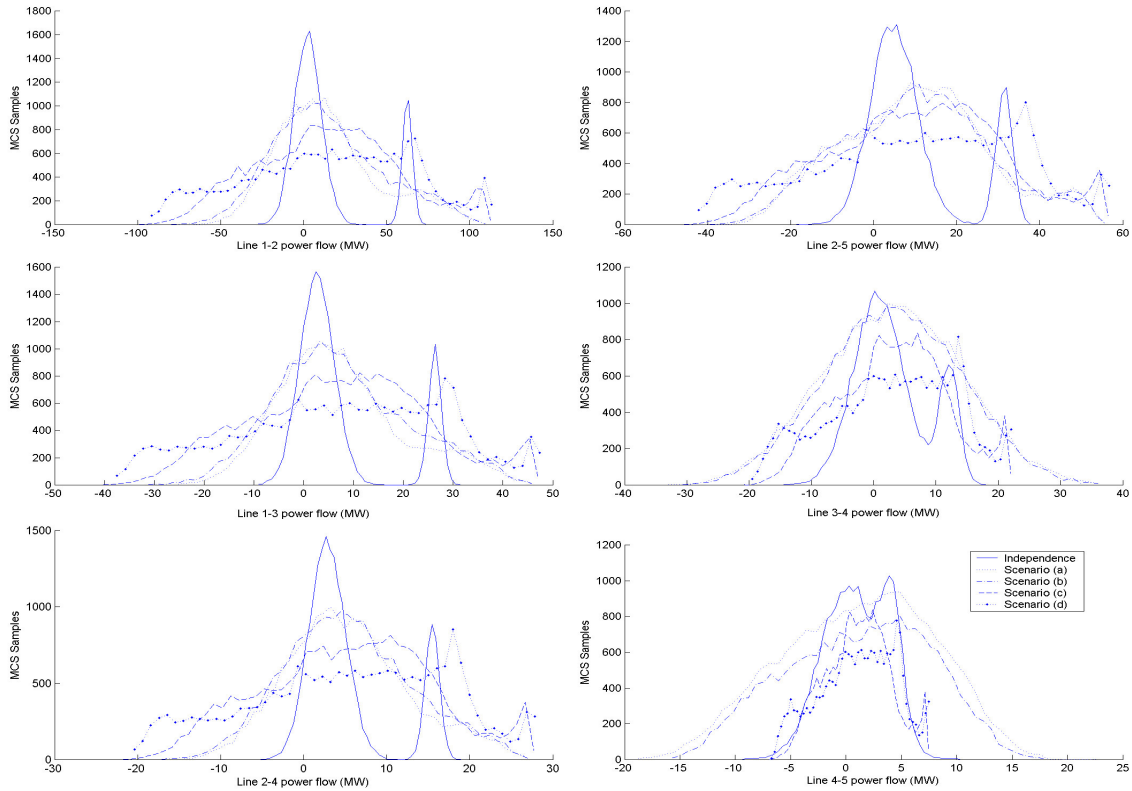

Figure 14: Power Flow Distributions for the system lines

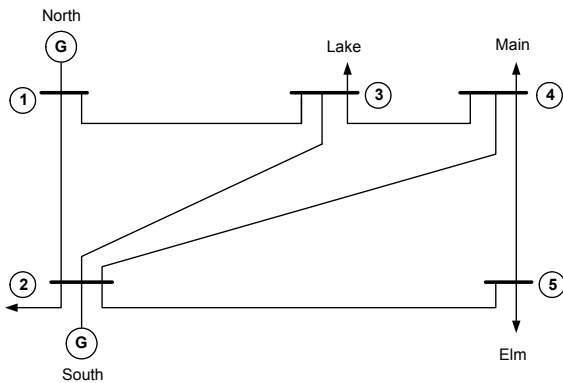

Figure 12: 5-bus / 7-branch Test System (Hale Network)

Seven clusters are defined for the test system: four load clusters (DNs 2-3-4-5) and three WTG clusters (DNs 3-4-5). Five different dependence scenarios are considered for the system analysis: the lower stochastic bound (all r.v. are independent) and four upper bounds. They are shown in Fig. 13, ranked in increasing order of severity for the system. First the different clusters are considered to be independent, corresponding to the case that no severe positive dependence appears between the loads and the stochastic generation in the different DNs (case a). Seven random generators U_i are used for the system sampling in this case. In case b, the stochastic generation remains independent between the different DNs, but the loads in the system are considered to be positively dependent (same type of loads in the different DNs), therefore the upper comonotonic bound is used for their com-

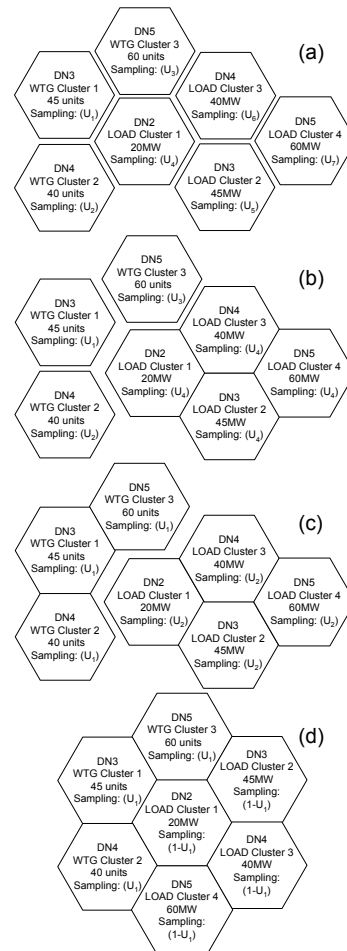

Figure 13: Clusters for system upper bound stochastic modelling

bined modelling. In this case, four random generators are needed for the sampling of the system. In the next case c, the stochastic generation is also considered to be positively correlated, but they are not correlated to the load in the system. In this case, two random generators are enough. Finally, in case d, positive correlation is considered between the stochastic generation and the consumption in the system (this may occur due to their mutual dependence on weather). Thus, countermonotonic sampling is used in order to define the extreme distribution for the system output, which is the worst case for the system stochastic modelling. In this case, only one random generator is used for the sampling of the system.

A 20000-sample MCS was used for the system simulation. The total number of random variables involved in the analysis is 149: 45 WTG r.v. for DN 3, 40 WTG r.v. for DN 4, 60 WTG r.v. for DN 5 and 4 load distributions. The simulation duration was 3577 seconds on a Pentium IV 2.4GHz machine.

As mentioned in [27] the simulation results show that the mean values are the same for all the different dependence scenarios, while the standard deviations are minimal for the lower stochastic bound and maximal for the upper bounds. Thus, different power flow distributions around the same central point are obtained, as can be seen in Fig. 14 where the power flow distributions for all the system lines are presented. Again the lower bound represents the 'best-case scenario', giving distributions with minimum dispersion for all the system lines, while the 'worst-case scenarios' are presented for different dependence scenarios in the different lines.

As can be seen from the power flow distributions (Fig. 14), the presence of stochastic generation in the system results in highly bidirectional power flows. An analysis that is based on the Stochastic Bounds Methodology focuses on the worst case of aggregated stochastic stress for the system and is therefore quite conservative. All real cases correspond to more moderate stochastic dependence structures and therefore lower system stress. The advantage of the use of the methodology is that the engineer may measure the risk of exceeding the system safety margins for these worst-case scenarios and can take respective actions to reduce it. For example, the system analysis shows that the lines 1-2 and 2-5 are the ones that are mostly stressed. During system operation, a large amount of power is forced through line 1-2. This may be confronted by the installation of a FACTS device in the line, in order to redirect the power. Such actions can of course be analyzed using the same methodology and the improvement of the system behavior can be assessed.

7 CONCLUSIONS - FURTHER WORK

The integration of stochastic generation in power systems necessitates the use of new modelling techniques to cope with the generation uncertainty of this small-scale, distributed, non-dispatchable generation. A novel modelling approach has been presented, consisting of the following parts:

1. Decoupling of the marginal behavior of the stochastic generators from the stochastic dependence modelling.
2. Definition of clusters of positively dependent random variables. The dependence structure in the cluster is approximated using extreme dependence concepts.
3. Definition of the dependence structure between the clusters.

Based on the concepts presented in this contribution, the extremes of stochastic generation in a power system can be modelled. But, is it enough for the analysis of the impact of stochastic generation in the system? The case of independence provides the 'best-case' scenario, the minimum effect by the stochastic generation. The extreme dependence concepts of comonotonicity and countermonotonicity can be used for the definition of the maximum aggregated effect of the stochastic generation to the system (worst-case scenario). In the cases of geographically small systems, these concepts can provide a realistic approach to study the impact of stochastic generation, due to the existence of strong positive dependencies between the system inputs. Although these considerations lead to a better understanding of the impact of stochastic generation to the system, they lead to conservative results, especially when applied in large power systems. The differences between these 'stochastic bounds' can be very large, while reality will fall somewhere in between. In this case, it is important to quantify the dependencies more in detail and find new techniques for that. New techniques that specify dependence structures can be considered [22]. Based on this approach, expert judgement can be used for the definition of the stochastic behavior of the system [28].

REFERENCES

- [1] Electrical Power Systems and Electrical Power Processing Groups, Delft and Eindhoven Universities of Technology, "Intelligent power systems project." World Wide Web, <http://www.intelligentpowersystems.nl>, 2003.
- [2] CIGRE, "Impact of increasing contribution of dispersed generation on the power system." CIGRE Study Committee No 37, Working Group 23, Final Report, September 1998.
- [3] M. Shahidehpour, H. Yamin, and Z. Li, *Market Operations in Electric Power Systems*. Wiley Interscience - IEEE Press, 2002.
- [4] R. Billinton and R. N. Allan, *Reliability Evaluation of Engineering Systems*. New York: Plenum Press, second ed., 1992.
- [5] J. Grainger and W. D. Jr. Stevenson, *Power Systems Analysis*. Electrical Engineering, McGraw-Hill International Editions, 1994.

- [6] G. Papaefthymiou, P. H. Schavemaker, and L. van der Sluis, "Survey on the modelling of the uncertainty in 'distributed' power systems," in *IEEE Young Researchers Symposium, Delft, The Netherlands*, March 18-19 2004.
- [7] G. J. Anders, *Probability Concepts in Electric Power Systems*. Wiley Interscience, 1990.
- [8] L. A. Zadeh, "Fuzzy sets as a basis for a theory of possibility," *International Journal of Fuzzy Sets & Systems*, vol. 1, pp. 3–28, January 1978.
- [9] V. Miranda and J. T. Saraiva, "Fuzzy modelling of power system optimal load flow," *IEEE Transactions on Power Systems*, vol. 7, pp. 843–849, May 1992.
- [10] Z. Wang and F. L. Alvarado, "Interval arithmetic in power flow analysis," *Proceedings of the Power Industry Computer Applications on Power Systems*, vol. 5, pp. 182–190, February 1990.
- [11] M. Reza, G. Papaefthymiou, P. H. Schavemaker, W. L. Kling, and L. van der Sluis, "Transient stability analysis of power systems with distributed energy systems," in *CIGRE 2005 Symposium "Power Systems with Dispersed Generation"*, Athens, Greece, April 17-20 2005.
- [12] A. Papoulis and S. U. Pillai, *Probability, Random Variables and Stochastic Processes*. Electrical and Computer Engineering, McGraw-Hill, fourth ed., 2002.
- [13] R. N. Allan, C. H. Grigg, D. A. Newey, and R. F. Simmons, "Probabilistic power-flow techniques extended and applied to operational decision making," *Proceedings IEE*, vol. 123, pp. 1317–1324, December 1976.
- [14] R. N. Allan and M. R. G. Al-Shakarchi, "Linear dependence between nodal powers in probabilistic a.c. load flow," *Proceedings IEE*, vol. 124, pp. 529–534, June 1977.
- [15] A. M. L. da Silva, V. L. Arienti, and R. N. Allan, "Probabilistic load flow considering dependence between input nodal powers," *IEEE Transactions on Power Apparatus & Systems*, vol. PAS-103, pp. 1524–1530, June 1984.
- [16] M. C. Caramanis, R. D. Tabors, K. S. Nochur, and F. C. Schweppe, "The introduction of non-dispatchable technologies as decision variables in long-term generation expansion models," *IEEE Transactions on Power Apparatus & Systems*, vol. PAS-101, pp. 2658–2666, August 1982.
- [17] J. A. Bloom, "Probabilistic production costing with dependent generating sources," *IEEE Transactions on Power Apparatus & Systems*, vol. PAS-104, pp. 2064–2070, August 1985.
- [18] R. Billington and W. Li, *Reliability Assessment of Electric Power Systems Using Monte Carlo Methods*. Plenum Press, 1994.
- [19] J. G. Slootweg, *Wind Power: Modelling and Impact on Power Systems Dynamics*. PhD thesis, Delft University of Technology, Delft, the Netherlands.
- [20] I. Troen and E. L. Petersen, *European Wind Atlas*. Published for the CEC by Riso National Laboratory, Roskilde, Denmark, 1989.
- [21] G. Papaefthymiou, A. Tsanakas, P. H. Schavemaker, and L. van der Sluis, "Design of 'distributed' energy systems based on probabilistic analysis," in *8th International Conference on Probability Methods Applied to Power Systems (PMAAPS)*, Iowa State University, Ames, Iowa, USA, September 12-16 2004.
- [22] D. Kurowicka and R. M. Cooke, "Uncertainty analysis with high dimensional dependence modelling." to be published by Wiley Press.
- [23] J. Dhaene, M. Denuit, M. J. Goovaerts, R. Kaas, and D. Vyncke, "The concept of comonotonicity in actuarial science and finance: Theory," *Insurance: Mathematics and Economics*, vol. 31(1), pp. 3–33, 2002.
- [24] M. Denuit, J. Dhaene, and C. Ribas, "Does positive dependence between individual risks increase stop-loss premiums?," *Insurance: Mathematics and Economics*, vol. 28(3), pp. 305–308, August 2001.
- [25] P. Embrechts, A. McNeil, and D. Straumann, "Correlation and dependence in risk management: Properties and pitfalls," *Risk Management: Value at Risk and Beyond*, pp. 176–223, 2002.
- [26] G. Papaefthymiou, J. Morren, P. H. Schavemaker, W. L. Kling, and L. van der Sluis, "The role of power electronic converters as intelligent interfaces in distributed power systems: Stochastic steady state analysis," in *CIGRE 2005 Symposium "Power Systems with Dispersed Generation"*, Athens, Greece, April 17-20 2005.
- [27] G. Papaefthymiou, A. Tsanakas, M. Reza, P. H. Schavemaker, and L. van der Sluis, "Stochastic modelling and analysis of horizontally-operated power systems with a high wind energy penetration," in *2005 St. Petersburg PowerTech Conference, St. Petersburg, Russia*, June 27-30 2005.
- [28] R. M. Cooke, *Experts in Uncertainty: Opinion and Subjective Probability in Science*. Oxford University Press, Inc., New York, 1991.