

ROBUST POWER SYSTEM STABILIZER TUNING BASED ON MULTIOBJECTIVE DESIGN USING HIERARCHICAL AND PARALLEL MICRO GENETIC ALGORITHM

Komsan Hongesombut, Sanchai Dechanupaprittha, Yasunori Mitani, and Issarachai Ngamroo*

Department of Electrical Engineering, Kyushu Institute of Technology, Kitakyushu, Fukuoka 804-8550, JAPAN

*Electrical Power Engineering Program, Siridorn International Institute of Technology, Thammasat University, Patumthani 12121, THAILAND
komsan@ele.kyutech.ac.jp

Abstract – This paper presents a method to simultaneously tune multiple power system stabilizers (PSSs) in multimachine power systems based on multiobjective design by using hierarchical genetic algorithm (HGA) and parallel micro genetic algorithm (micro-GA). The presented method translates the tuning problem into a multi-input multi-output (MIMO) control system. In derivation of the objective function, damping performance by keeping all eigenvalues within the design specification of D-Stability region, robust stability of control system against system uncertainties and number of PSSs are taken into consideration. The PSSs are tuned to simultaneously shift the lightly damped and undamped oscillation modes to a specific stable zone in the s-plan and to automatically identify the proper choice of PSS locations as well as to maximize the multiplicative stability margin (MSM) by using eigenvalue-based multiobjective function. The proposed method is tested and validated through small and large signal simulations in a 16-machine and 68-bus power system.

Keywords: Hierarchical genetic algorithm, parallel micro genetic algorithm, power system stabilization, robust power system stabilizer tuning

1 INTRODUCTION

With the increasing electric power demand and need to operate power system in a faster and more flexible manner as well as lower generation cost in the deregulated competitive environment, modern power system can reach stressed conditions more easily than the past. These cause unstable or poorly damped oscillations that can be observed more frequently in today's power systems. Therefore, serious consideration is now being given on the issue of increasing power system stabilization performance. Over the decades, power system stabilizer (PSS) has been employed by electric utilities in real power systems as it has been shown to be the most cost effective for electromechanical damping control [1,2]. Several approaches based on modern control theories have been successfully applied to design different power system stabilizer structures. However utilities prefer to use lead-lag structure due to its simple structure and reliability in applying with real power systems. To increase the damping performance of power systems, researches have paid attention to tune these stabilizers simultaneously.

In PSS tuning, sequence of tuning and selection of location are critical involved factors to achieve optimal stabilization performance. PSS can be tuned to improve damping at some specific modes, but it may produce adverse effects in other modes. On the other hand, different placement of PSS makes the oscillation behaviors quite different at different operating conditions. Several researches using optimization methods to tune PSSs simultaneously have to firstly determine the location of each PSS by use of participation factor. By this way, since the location has always been fixed, the optimal damping performance can be guaranteed only with this specific fixed structure. Generally, several PSSs with improper setting may produce severely adverse effects to power systems. Since these behaviors change in a rather complex manner, a set of PSS may no longer yield satisfactory results when the place is not chosen appropriately. As a result, it is necessary to reduce these adverse effects by using only necessary number of PSSs.

Several literatures have proposed using GA to tune multiple PSSs [3-5]. In these studies, however, the uncertainty model is not embedded in the mathematical model of the power systems. Furthermore, the robust stability against system uncertainties is not taken into consideration in the optimization process. Thus, the robust stability margin of the power system may not be guaranteed in the face of several uncertainties. The robustness performance can be aggregated in the optimization by including several operating conditions as described in [3-6]. However, the difficulties are how to sufficiently choose number of operating conditions in order to achieve the desired robustness and the extensive computation time by large number of repetitive computation of several linearized models for each operating condition.

To overcome these problems, a method to simultaneously tune multiple PSSs based on multiobjective design by using hierarchical genetic algorithm (HGA) and parallel micro genetic algorithm (micro-GA) is presented. The presented method translates the tuning problem into a multi-input multi-output (MIMO) control system. In derivation of the objective function, damping performance, robust stability of control system against system uncertainties and number of power system stabilizers (PSSs) are taken into consideration. The

first and second objective functions are to enhance the damping performance by keeping all eigenvalues within the design specifications of D-stability region [7]. The third objective is to maximize the multiplicative stability margin (MSM) which can be used to guarantee the robust stability margin of close-loop system against uncertainties. The fourth objective function is to minimize adverse effects from unnecessary number of PSSs. HGA is applied to the development of tuning procedure to automatically select the location and obtain the control parameters simultaneously [6,8]. Since the optimization becomes computationally extensive by large number of repetitive computation, the parallel micro-GA developed by authors is utilized. The performance and robustness of the suggested tuning method are tested and validated through small signal and large signal simulations in a 16-machine and 68-bus power system.

2 STUDIED POWER SYSTEM

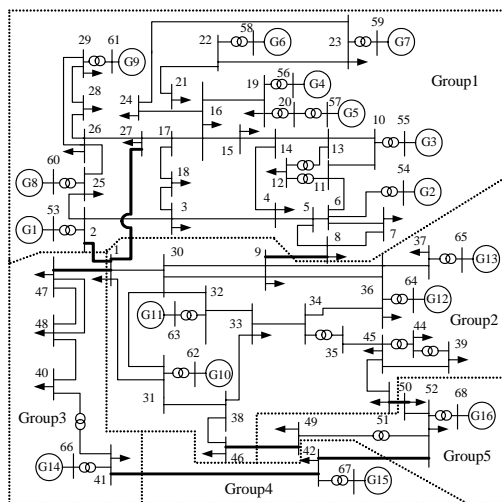

Figure 1: A 68-bus and 16-generator power system

Figure 1 shows the power system used in this study. The power system consists of 5 coherent groups representing a reduced order of the New England and New York interconnected system. The thick lines indicate the major weak tie lines that cause the low frequency inter-area oscillations. Details of power system parameters are given in [9].

3 PROPOSED POWER SYSTEM STABILIZER TUNING METHOD

3.1 Hierarchical genetic algorithm (HGA)

Each hierarchical chromosome consists of a multi-level of genes. Figure 2 shows the HGA chromosome representation with one-level control genes and parametric genes including the interface system of HGA chromosome structure and simulation package. With this configuration, the control genes are analogous to the PSS locations. The control gene signified as “0” in

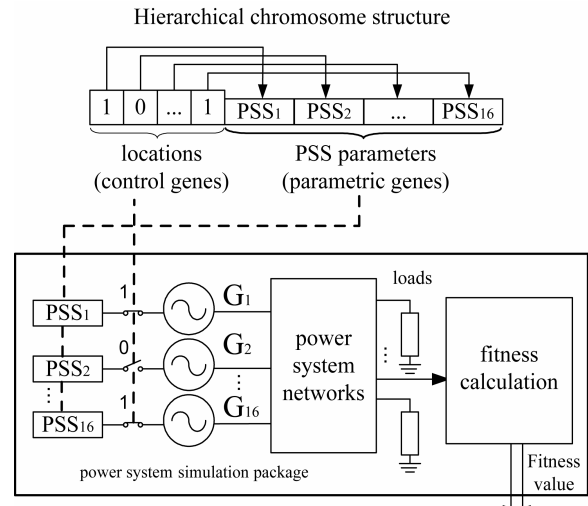

Figure 2: Hierarchical chromosome structure and system interface

the corresponding site, is not being activated meaning that the PSS at the corresponding location will not be installed into the power system during the simulation. Parametric genes are analogous to the PSS parameters to be optimized. Using the HGA concept, locations and PSS parameters can be simultaneously tuned.

3.2 Parallel micro genetic algorithm

Typically, if the population size in simple GA is too large, the simple GA tends to take longer time to converge upon a solution. Conversely, if the population size is too small, it is in danger that simple GA can converge to a suboptimal solution. The simple GA cannot apply a small population size due to the lack of enough diversity in the population pool to escape from the local optima.

In this paper, a micro-GA presented in [6] is used. Additionally, multipopulation evolutionary concept and parallelization are new features to implement in this study. A single population micro-GA performs well on a wide variety of problems. However, better results can be obtained by introducing multiple subpopulations. The proposed parallel micro-GA models the evolution of a species in a similar way to nature. Figure 3 shows the implementation of proposed parallel micro-GA. The parallel micro-GA is implemented through a Dynamic Host Configuration Protocol (DHCP) server. For each computer node, it is divided into multiple subpopulations. These subpopulations evolve independently of each other for a certain number of generations. Then, the migration process is achieved by distributing the best individual between the subpopulation. The scheme of migration provides genetic diversity occurring in the subpopulation by exchanging of information between subpopulation.

The procedure of the parallel micro-GA can be described as follows:

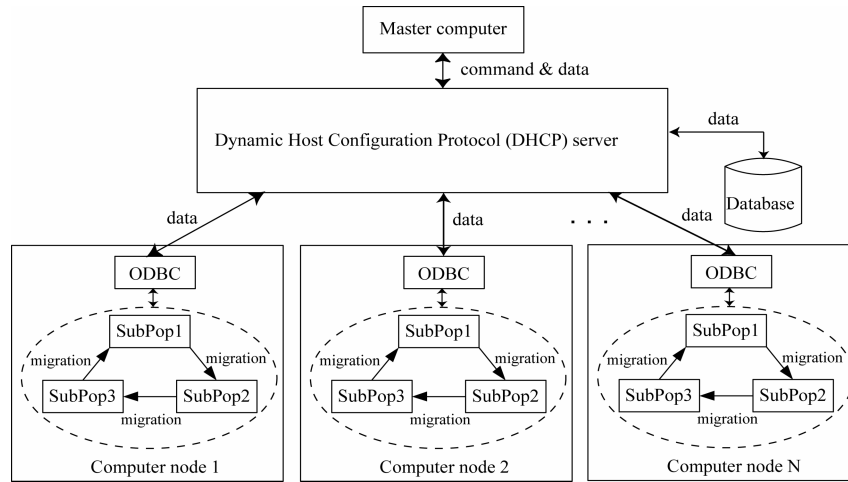

Figure 3: Parallel micro genetic algorithm

Step 1: Master computer initializes the system counter to zero.

Step 2: Each computer node initializes the generation counter to zero.

Step 3: Each computer node loads the best individual from the database and keeps the loaded solution in the subpopulation 1, then initializes the rest population.

Step 4: Each subpopulation for each computer node performs micro-GA by executing 5 operation steps as follows;

Step 4.1: Evaluate the fitness of each individual.

Step 4.2: Perform the tournament selection.

Step 4.3: Perform the discrete recombination.

Step 4.4: Perform elitism mechanism.

Step 4.5: Check convergence. If converged by the constraint that the best fitness is different from average fitness by 5% or less, then reinitialize the subpopulation by keeping the recent best individual and send it to the database through DHCP server.

The database is required to store set of obtaining solutions. A prototype database system has been implemented in Microsoft Access 2000 in Windows XP professional operative system. Microsoft Open Database Connectivity (ODBC) driver is used to enable communication between database management systems and SQL-based applications. Master computer can be used to collect results from the database, and to insert test solution into the database without interrupting the operation of each computer node.

3.3 Formulation of problem

3.3.1 Linearized model of power system and PSS structure

A linear representation of an open-loop power system is obtained around the nominal operating point. Each generator is equipped with a simplified exciter and is represented by a 5 state transient model. The state equations of a linearized power system (A, B, C, D) in Figure 1 can be expressed as:

$$\Delta \dot{x} = A\Delta x + B\Delta u_{PSS},$$

$$\Delta y = C\Delta x + D\Delta u_{PSS},$$

$$\Delta u_{PSS} = K_{PSS}\Delta \omega, \quad (1)$$

where, $\Delta x = [\Delta \delta, \Delta \omega, \Delta e'_d, \Delta e'_q, \Delta E_{fd}]^T$, ($5n \times 1$);

$\Delta y = \Delta \omega$, ($m \times 1$); $\Delta \delta$ denotes the deviation of rotor angle, ($n \times 1$); $\Delta \omega$ is the deviation of rotor speed, ($n \times 1$); $\Delta e'_d$ and $\Delta e'_q$ are the deviations of transient internal voltage of a generator in d -axis and q -axis, respectively, ($n \times 1$); ΔE_{fd} is the deviation of field voltage, ($n \times 1$); K_{PSS} is the diagonal controller with designed PSSs as diagonal elements, ($m \times m$); Δu_{PSS} is the control output signal of K_{PSS} , ($m \times 1$); m and n are the numbers of machines and PSSs, respectively. Note that the system (1) is an MIMO control system and is referred to as the nominal plant G .

The transfer function of PSS is defined as:

$$\Delta u_{PSS,i} = K_i \cdot \frac{sT_w}{1+sT_w} \cdot \frac{1+sT_{1i}}{1+sT_{2i}} \cdot \frac{1+sT_{3i}}{1+sT_{4i}} \cdot \Delta \omega_i, \quad (2)$$

where, $i=1, \dots, m$, $\Delta u_{PSS,i}$ and $\Delta \omega_i$ are the control output signal and the rotor speed deviation at the i^{th} machine, respectively; K_i is a controller gain; T_w is a wash-out time constant (s); and T_{1i} , T_{2i} , T_{3i} and T_{4i} are time constants (s). In this paper, T_w is set to be large enough and can be considered as a constant (10 s). The control parameters K_i , T_{1i} , T_{2i} , T_{3i} and T_{4i} are searched based on the objective function explained in the following subsection.

3.3.2 Objective function

In derivation of the objective function, damping performance, robust stability of control system against system uncertainties, numbers of PSSs are taken into consideration. The main purpose of the PSS controller is to improve the system damping following any disturbances, therefore, the damping ratio (ζ) is used as a design specification. Assuming that eigenvalues corre-

sponding to the mode of oscillation can be determined as $-\sigma \pm j\omega_d$, the damping ratio is defined as:

$$\zeta = \frac{-\sigma}{\sqrt{\sigma^2 + \omega_d^2}} \quad (3)$$

The D-stability region as shown in Figure 4 is used to guarantee the desired damping ratio and the real part of control modes. For the robust stability of a system, the plant uncertainty is modeled as a multiplicative form demonstrated in Figure 5 [10]. Δ_m is a stable multiplicative uncertainty. Based on the small gain theorem, the closed loop system will be robustly stable if

$$|\Delta_m| < \frac{1}{|G \cdot K_{PSS} (1 - G \cdot K_{PSS})^{-1}|}, \quad (4)$$

where, the symbol $|\bullet|$ shows the magnitude of transfer function (\bullet) . Note that $G \cdot K_{PSS} (1 - G \cdot K_{PSS})^{-1}$ is the complementary sensitivity function, T . Based on this uncertainty representation, the robust stability margin can be guaranteed in term of MSM. In other words,

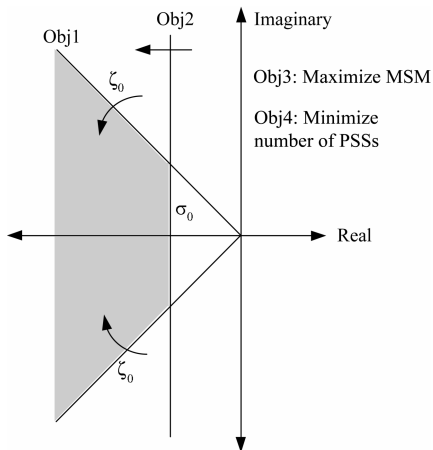

Figure 4: D-Stability region

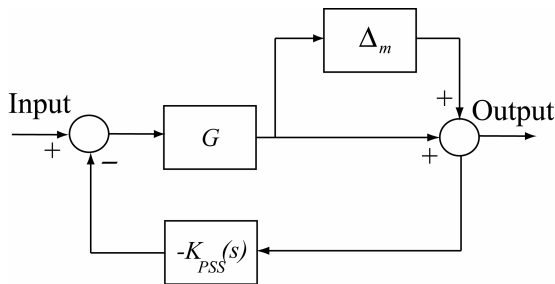

Figure 5: Feedback system with multiplicative uncertainty

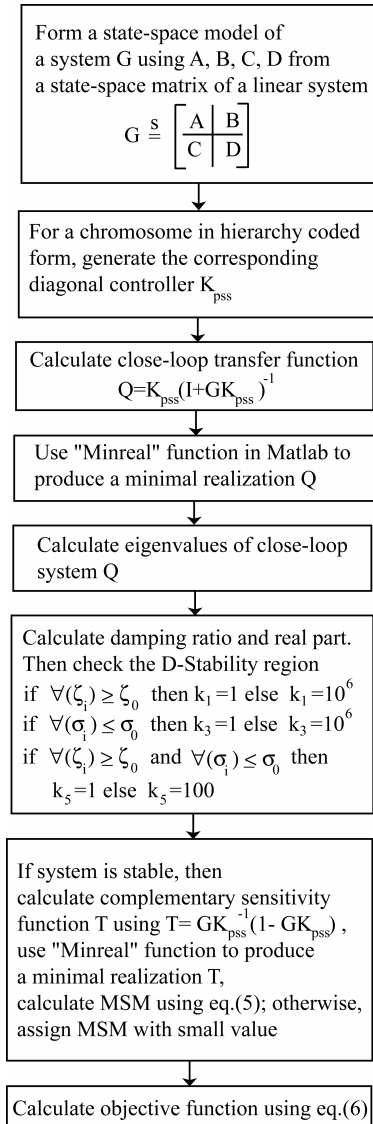

Figure 6: Flowchart for objective function evaluation

MSM also implies the maximum uncertainty bound and can be calculated by

$$MSM = \frac{1}{\|T\|_{\infty}}, \quad (5)$$

where, $\|T\|_{\infty}$ is the ∞ -norm of T . From (5), it is obvious that by minimizing $\|T\|_{\infty}$, the MSM increases and the robust stability will be ensured [10].

Finally, the control problem can be formulated as the following optimization problem:

$$\begin{aligned} \text{Min } F &= \text{Obj1} + \text{Obj2} + \text{Obj3} + \text{Obj4} \\ &= k_1 \cdot k_2 \cdot \left| (\min_{1 \leq i \leq n} \zeta_i) - \zeta_0 \right| + \\ &\quad k_3 \cdot k_4 \cdot \left| (\max_{1 \leq i \leq n} \sigma_i) - \sigma_0 \right| + k_5 \cdot k_6 / \text{MSM} \\ &\quad k_7 \cdot N \end{aligned} \quad (6)$$

Table 1: PSS parameter set obtained by the proposed method for each case study.

	G1	G2	G3	G4	G5	G6	G7	G8	G9	G10	G11	G12	G13	G14	G15	G16	
Case B	K	38.42	15.45	28.52	16.09	-	8.263	-	34.81	29.70	17.43	7.048	29.39	40.00	-	35.57	38.12
	T ₁	0.034	0.057	0.100	0.091	-	0.100	-	0.074	0.084	0.044	0.100	0.097	0.060	-	0.022	0.097
	T ₂	0.030	0.010	0.069	0.010	-	0.038	-	0.048	0.015	0.040	0.051	0.020	0.068	-	0.014	0.044
	T ₃	0.047	0.085	0.054	0.051	-	0.097	-	0.081	0.033	0.061	0.052	0.074	0.068	-	0.034	0.078
	T ₄	0.090	0.063	0.007	0.083	-	0.058	-	0.012	0.070	0.010	0.032	0.073	0.060	-	0.024	0.020
Case C	K	3.447	7.642	6.488	10.29	-	6.960	10.73	6.087	11.91	13.15	3.449	14.46	20.00	17.62	15.08	23.87
	T ₁	0.516	0.096	0.048	0.069	-	0.096	0.001	0.103	0.040	0.171	0.173	0.001	0.001	0.033	0.095	0.069
	T ₂	0.069	0.010	0.036	0.026	-	0.125	0.001	0.004	0.085	0.013	0.007	0.001	0.057	0.044	0.045	0.059
	T ₃	0.108	0.066	0.192	0.105	-	0.102	0.350	0.156	0.125	0.115	0.075	0.088	0.038	0.322	0.609	0.001
	T ₄	0.030	0.011	0.003	0.026	-	0.080	0.019	0.054	0.011	0.046	0.013	0.004	0.011	0.049	0.079	0.058
Case D	K	7.107	13.49	17.28	10.30	-	14.77	12.59	10.63	20.15	13.78	3.388	26.38	31.60	34.93	19.28	25.10
	T ₁	0.528	0.096	0.017	0.068	-	0.094	0.001	0.133	0.040	0.202	0.177	0.001	0.001	0.001	0.001	0.342
	T ₂	0.069	0.010	0.067	0.059	-	0.001	0.001	0.004	0.148	0.076	0.007	0.001	0.120	0.173	0.206	0.014
	T ₃	0.009	0.116	0.191	0.120	-	0.213	0.215	0.156	0.164	0.120	0.076	0.088	0.038	0.421	0.168	0.011
	T ₄	0.023	0.011	0.003	0.040	-	0.080	0.019	0.042	0.002	0.050	0.013	0.004	0.001	0.174	0.223	0.312

subject to

$$\text{if } \forall(\zeta_i) \geq \zeta_0 \text{ then } k_1=1 \text{ else } k_1=10^6$$

$$\text{if } \forall(\sigma_i) \leq \sigma_0 \text{ then } k_3=1 \text{ else } k_3=10^6$$

$$\text{if } \forall(\zeta_i) \geq \zeta_0 \text{ and } \forall(\sigma_i) \leq \sigma_0 \text{ then } k_5=1 \text{ else } k_5=100$$

where $i=1,2,3, \dots, n$ (number of complex eigenvalues), ζ_i is the damping ratio of i^{th} complex eigenvalue, σ_i is the damping factor of i^{th} complex eigenvalue, k_1, k_3 and k_5 are conditional penalty values, k_2, k_4, k_6 and k_7 are scaling factors to weight each objective function and N is number of PSSs.

The proposed parallel micro-GA is then used to optimize the function in (6). The goal is to maximize the damping ratio, to minimize real part of eigenvalues, to maximize MSM and to minimize the number of PSSs. The procedure of objective function evaluation at each generating step is shown in Figure 6. It should be noted that the norm imposed by (5) cannot guarantee the entire range of operating conditions. In practice, power system should be stable for small and large changes. The performance of a system with designed controllers should not be sensitive to system changes. This can be ensured by using (5) for a certain degree of uncertainty around the nominal operating condition. If this is not achieved well, we may need to include more than one operating condition into the objective function in (6).

4 RESULTS AND DISCUSSIONS

Using the described multiobjective function in (6), multiple PSSs were simultaneously tuned. In the tuning process, these parameters were setup; gains of PSSs with bounds ranging from 0 to 40, time constants of PSSs with bounds ranging from 0 to 5 seconds, k_2, k_4, k_6 , and k_7 with constants at 400, 40, 10 and 1 respectively. The population size P was set to 5 and maximum generation N was 60 for each subpopulation and system counter was 10.

The robustness of power system controls need to be tested on various changes of conditions. Therefore, the dominant complex eigenvalues are plotted on the same figure. The following scenarios were used in the small

signal simulation: case 1- all lines are in service, case 2- line 1-27 is out of service, case 3- line 8-9 is out of service, case 4- line 1-47 is out of service, case 5- line 6-49 is out of service and case 6- line 42-52 is out of service. PSS parameters and locations obtained by the proposed tuning method are shown in Table 1. In this study, all generators are fitted with PSSs in Table 1 and the outage scenario of PSS does not consider. The following 4- case studies were carried out. The damping ratio and real part have been considered as a design parameter. They have been chosen manually. However, it has been suggested that the damping ratio of each electromechanical mode should be greater than 5% based on the practical power system operation.

Case A- open-loop system (no PSS): It is obvious in Figure 7 that the power system is very risky to be unstable. Many complex modes have minimum damping ratio less than the minimal requirement of 5%.

Case B- minimum damping ratio $\zeta_0 = 5\%$ and maximum real part $\sigma_0 = -0.4$: Figure 8 shows that all eigenvalues can be shifted to the specified D-stability region. The proposed method requires only 13 PSSs to satisfy the minimal required performance. However, each PSS tends to use high gain compared to those from other cases.

Case C- minimum damping ratio $\zeta_0 = 15\%$ and maximum real part $\sigma_0 = -0.4$: ζ_0 is increased from 5% to 15% by keeping σ_0 at constant -0.4 . It can be seen in Figure 9 that eigenvalues for local modes can be improved significantly. However, it has minor effects to improve the performance of inter-area modes by using only *Obj 1*. The required numbers of PSSs to satisfy the required performance is increased from 13 to 15. However, each PSS tends to use lower gain.

Case D- minimum damping ratio $\zeta_0 = 15\%$ and maximum real part $\sigma_0 = -1.0$: To improve the stability of inter-area modes, the requirement for maximum real part σ_0 of *Obj 2* was set to -1.0 . In Figure 10, the inter-area modes at low frequencies can be shifted to have higher damping ratio. This can be said that low frequency modes can be significantly improved by reducing the value of *Obj 2*.

In order to test the performance and robustness of the obtaining PSSs, non-linear time domain simulations for PSSs in Case D were chosen for simulations with different fault locations at major tie lines. Three-phase to ground fault on each line was applied for 6 cycles. The results shown in Figure 11 to Figure 13 indicate that in all cases, the responses of generator speeds for 16 generators can go to steady state with superior damping performance. Therefore, it can be concluded that the obtaining PSSs met the objectives in terms of performance specification and robustness.

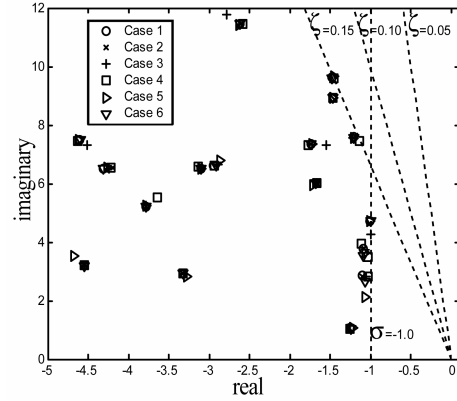

Figure 10: Eigenvalues of Case D

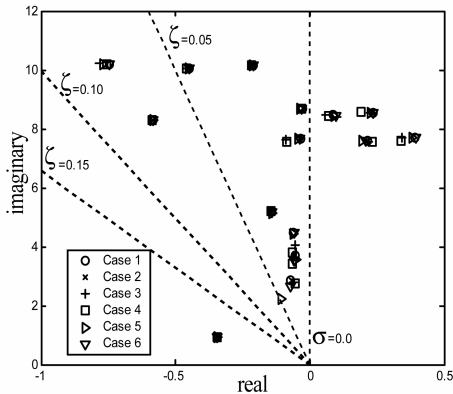

Figure 7: Eigenvalues of Case A

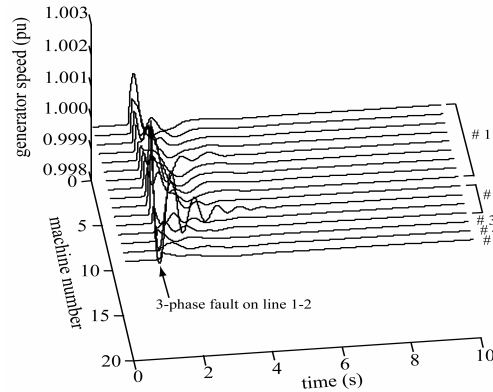

Figure 11: Generator speeds (fault on line 1-2)

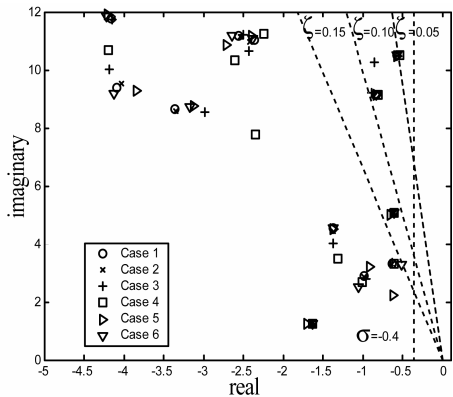

Figure 8: Eigenvalues of Case B

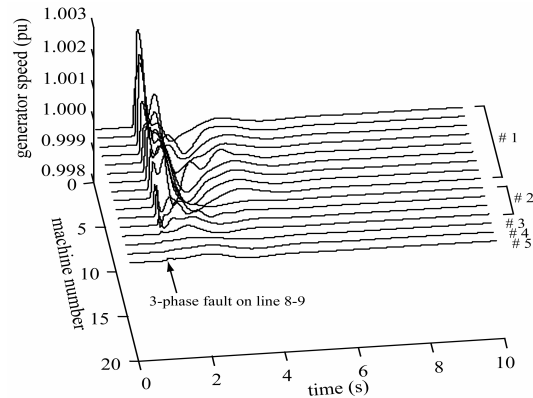

Figure 12: Generator speeds (fault on line 8-9)

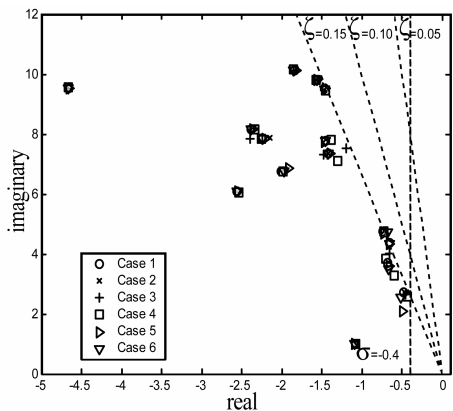

Figure 9: Eigenvalues of Case C

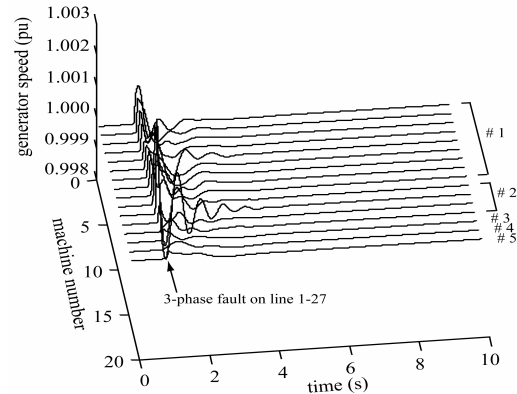

Figure 13: Generator speeds (fault on line 1-27)

5 CONCLUSIONS

In this paper, a method to simultaneously tune multiple power system stabilizers (PSSs) based on multiobjective design by using HGA and parallel micro-GA is proposed. The need for location search is to avoid using participation factor to obtain the possible PSS location. Therefore, by using an automate method, it is possible and flexible to obtain the optimal performance for any design specifications. By using the eigenvalue-based multiobjective function to guarantee the performance specification and robustness, lightly damped and undamped oscillation modes are able to be shifted to a specific stable region in the s -plane and the appropriate PSS location can be obtained simultaneously. From the results, the eigenvalue analysis confirms the improvement of close-loop plant performance. Non-linear time domain simulation confirms the effectiveness and robustness of the obtaining PSSs by improving in dynamical oscillations.

6 ACKNOWLEDGMENT

This work is supported by "The JSPS Postdoctoral Fellowship for Foreign Researchers" program from the Japan Society for the Promotion of Science (JSPS).

REFERENCES

- [1] E. V. Larsen and D. A. Swann, "Applying Power System Stabilizers, Part I; General Concepts, Part II; Performance Objectives and Tuning Concepts, Part III; Practical Considerations", IEEE Trans. on Power Apparatus and Systems, Vol. PAS-100, pp. 3017-3046, 1981.
- [2] P. Kundur, "Power System Stability and Control", New York, McGrawHill, 1993.
- [3] Y. L. Abdel-Magid, M. A. Abido, S. Al-Baiyat, and A. H. Mantawy, "Simultaneous Stabilization of Multimachine Power Systems Via Genetic Algorithms", IEEE Trans. on Power Systems, Vol.14, No.4, pp.1428-1439, November 1999.
- [4] A. L. B. do Bomfim, G. N. Taranto and D. M. Falcão, "Simultaneous Tuning of Power System Damping Controllers Using Genetic Algorithms", IEEE Trans. on Power Systems, Vol.15, No.1, pp.163-169, February 2000.
- [5] Y. L. Abdel-Magid and M. A. Abido, "Optimal Multiobjective Design of Robust Power System Stabilizers Using Genetic Algorithms", IEEE Trans. Power Systems, Vo. 18, No. 3, pp. 1125-1132, August 2003.
- [6] K. Hongesombut, Y. Mitani and K. Tsuji, " Simultaneous Tuning of Power System Stabilizers Based on a Combined Method of a Micro-GA, HGA and Minimum Phase Control", Trans. IEE of Japan, Vol. 122-B, No. 12, pp. 1270-1277, December. 2002.
- [7] P. Shrikant Rao and Indraneel Sen, "A QFT-Based Robust SVC Controller for Improving the Dynamic Stability of Power Systems", Electric Power System Research, Vol. 46, Issue 3, pp. 213-219, September 1998.
- [8] K. Hongesombut, Y. Mitani, and K. Tsuji, "An Automated Approach to Optimize Power System Damping Controllers Using Hierarchical Genetic Algorithms", Proc. of Intelligent System Application to Power Systems, pp.3-8, June 2001.
- [9] G. Rogers, "Power System Oscillations", Boston: Kluwer Academic Publishers, 2000.
- [10] S. Skogestad and I. Postlethwaite, "Multivariable Feedback Control Analysis and Design", Chichester, John Wiley and Sons, 1996.