

LARGE-SCALE WIND POWER INTEGRATION, VOLTAGE STABILITY LIMITS AND MODAL ANALYSIS

Giuseppe Di Marzio
NTNU
Trondheim, Norway
giuseppe.di.marzio@elkraft.ntnu.no

Olav B. Fosso
NTNU
Trondheim, Norway
olav.fosso@elkraft.ntnu.no

Kjetil Uhlen
SINTEF Energy Research
Trondheim, Norway
Kjetil.Uhlen@sintef.no

Magni P. Pålsson
SINTEF Energy Research
Trondheim, Norway
Magni.T.Palsson@sintef.no

Abstract - This paper attempts to identify some basic relations between damping of the oscillation modes and voltage stability through the analysis of a simplified yet realistic two-area test system. The system consists of four equivalent generators, one of which represents a sizeable wind farm connected to the transmission system through a weak radial. The approach chosen has been to perform different types of stability analyses on different power flows and system configurations. Both static and dynamic simulations have been performed.

Keywords: *wind power, voltage control, voltage stability, reactive compensation, reactive power control, small signal stability, inter-area mode*

1. INTRODUCTION

The growing utilisation of wind power, especially in remote areas with favourable wind conditions but relatively weak transmission systems, brings new challenges for voltage control and reactive power compensation. The amount of integrated wind power in one area can be increased by using extra reactive power support, e.g. Static Var Compensator (SVC), thus increasing the voltage stability limit with respect to the produced active power at the wind farm [1].

It is recognised that voltage control and reactive power compensation have influence on the damping of the system's oscillation modes, but in an interconnected system it is not always obvious if this has a positive or negative impact. Furthermore, it is relevant to ask if changes in power system damping, e.g. caused by changes in power flow or stabilizer tuning, affect the voltage stability limits.

In this paper of particular interest is the study of the fundamental nature of low frequency inter-area modes of oscillations and power system damping as affected by the presence of a large wind farm [2]. Voltage stability and power system damping assessments are usually performed as separate studies. The objective of our research is to investigate possible correlations between voltage stability characteristics and damping of inter-area modes of oscillation.

This paper presents results from both static and dynamic computer simulations of a simplified yet realistic two-area test system over a range of operating conditions with and without wind power integrated. It illustrates possible operating circumstances, parameterised for different configurations and scenarios, which fulfil both voltage and small signal stability

requirements to enable secure and stable operations of the system in question. Small signal unstable conditions in an interconnected power system might be caused either by a large power transit in the tie line or a wrong tuning in the regulators. Application of adequate technology and control as Power System Stabilisers (PSS), allows the operation of large wind farms connected to the main transmission grid through weak radials. The aim of the second part of this research is to analyse how the tuning of the regulator's parameters, as time constants and gains, in the same area can affect the small signal and voltage stability limits.

2. DESCRIPTION OF THE STUDY SYSTEM

The test system is shown in Figure 1. This is a well known model introduced in [3] as a simple but yet realistic interconnected power system particularly useful for parametric studies.

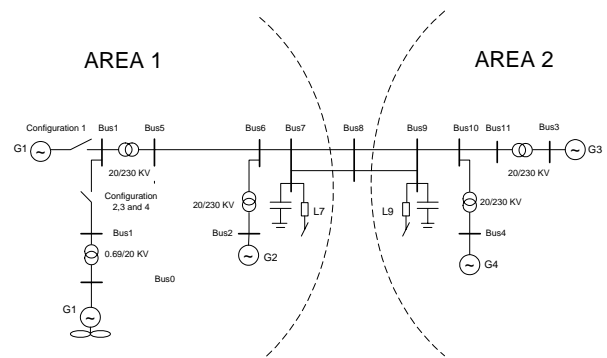

Figure 1 Four generator test system

The system contains eleven buses and two similar areas. These are connected by two tie lines (between bus 7 and 9) whose nominal voltage is 230 kV. Two loads, modelled as constant impedance (L7 and L9), and two shunt capacitors, supplying reactive power, are connected at the buses 7 and 9 respectively; as shown in figure1. Each area includes two equivalent generators G1 and G2 in area 1, G3 and G4 in area 2. The generators G2, G3 and G4 have been given a rating of 700 MVA unlike generator G1, which has been modelled as a sizeable rating machine in order to change the system configuration (with ratings of 100 MVA and 200 MVA). In this study G2, G3 and G4 have been modelled as synchronous generators while G1 is modelled either as a synchronous or as an asynchronous generator. In this latter case G1 represents a wind farm with reactive power compensation included at 690 V level (bus0); therefore the need of a step up transformer

to boost the voltage from 690 V to 20 kV (bus 1). Synchronous units are instead connected directly to the 20 kV level in the transmission system (bus1, bus2, bus3 and bus4) through a transformer with MVA rating equal to the individual unit rating. The length of the line between bus 5 and bus 6 has been increased to 125 km with respect to the original model (in [3] it was modelled as a 25 km line) and represents the weak radial connecting the remote unit, generator G1, to the rest of the system. Modelling the wind farm as induction generators is obviously a worst case scenario with respect to reactive power control. Four different system configurations have been chosen to parameterize the plots and make significant comparisons:

Configuration 1: synchronous

All equivalent generators have been modelled as synchronous machines representing conventional power plants. The generators are modelled with Thyristor rectifier exciters with high transient gain voltage regulators and Power System Stabilizers (PSS). This is regarded as our basic system configuration with no fluctuating power sources (such as wind power).

Configuration 2: asynchronous

The wind farm has been modelled as a sizeable induction generator G1, including a reactive power compensation of 20 MVar by shunt capacitors connected at 690 V level. The reactive power compensation is approximately equal to the no-load reactive power consumption of the induction generator.

Configuration 3: asynchronous with SVC

The wind farm has been modelled as a sizeable induction generator G1. Additionally, a sizeable SVC unit has been included. This is modelled as a linear controlled susceptance with maximum and minimum limits on the reactive power output. Within the operating limits the SVC performs automatic voltage control of the local high voltage node.

Configuration 4: asynchronous with SVC + contingency on one tie line

It is regarded as configuration 3 with an outage of line 1 between buses 7 and bus 8 connecting area 1 and area 2.

Both static and dynamic simulations have been performed using the computer program SIMPOW® [4]. Load flow simulations have been applied to establish initial conditions for the dynamic simulations upon which most of the results presented are based. The computer program used covers different kinds of power system analyses, such as load flow, transient stability, machine dynamic etc. In addition eigenvalue calculations and frequency-scan can be performed.

3. RESULTS

The damping ratio of the low frequency inter-area mode of oscillation has been plotted as a function of the

wind power produced. These curves have been reported for two possible scenarios:

- Area 1 importing power from Area 2
- Area 1 exporting power to Area 2

Oscillations associated with groups of generators, or groups of plants have frequencies in the range 0.1 to 0.8 Hz (see appendix 1).

For each plot, the four system configurations have been analysed over a range of different operating conditions simulated dynamically. Consequently the damping ratio of the eigenvalue associated with this mode has been plotted as a function of the wind power produced for the scenarios described above.

In this paper a damping ratio of 3% is defined as the minimum value for satisfactory small signal stable conditions.

To reveal the voltage stability limits, a linear increase of the produced active power at the wind farm has been simulated in the dynamic module of the program. The initial condition used as starting point in the dynamic simulation has been the result of a load flow with zero power at the sizeable unit. The mechanical torque (as wind turbine input), has been linearly increased from 0 to 2.25 p.u. within 20 sec. Thereafter the Power-Voltage curves (P-V curves) have been constructed by plotting the equilibrium points simulated dynamically (time series for the node voltage at bus1 as a function of the time series for the active power produced from generator G1). Among the voltage stable points [5] (upper part of the P-V curves), small signal stability has been assessed through the damping ratio of the inter-area mode of oscillation [3].

Area 1 importing power from Area 2

With no-load reactive power compensation, the stability margin is limited to 110 MW due to the lack of reactive power support and the damping ratio has appeared to be the lowest among the four configurations analysed (Figure 2).

One tie line outage has restricted the operating margins of the system because of local oscillation issues. Over 110 MW of wind power produced (185 MW power transferred in the tie line) the local mode in area 1 becomes larger than 3% and therefore stable (Figure 3). The system in the contingency case can be operated stably with a wind production between 110 and 160 MW.

The solution with only synchronous generators allows a maximum of 150 MW power produced at the G1 bus terminals and slightly higher damping ratio compared to the configuration 2. This limit is caused again by the local mode of oscillation in area 1 between G1 and G2, which becomes eventually unstable for 150 MW power produced at the remote location (Figure 4). The local mode of oscillation dramatically increases its amplitude (damping ratio increase) as we produce more active power at the remote location. Asynchronous generator with SVC shows a better damping ratio for any level of power produced and for any configuration analysed. In

addition to allow deeper wind power penetration, reactive power compensation through the SVC gives a significant improvement to the damping ratio of the inter area mode which is above the edge of 8% in the range 45 MW -180 MW (Figure 2).

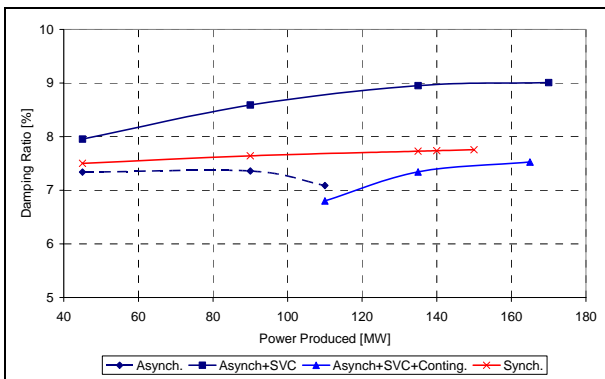

Figure 2: Damping ratio vs. power produced at the G1 terminals. 100 MVA rated machine, area 1 importing from area 2

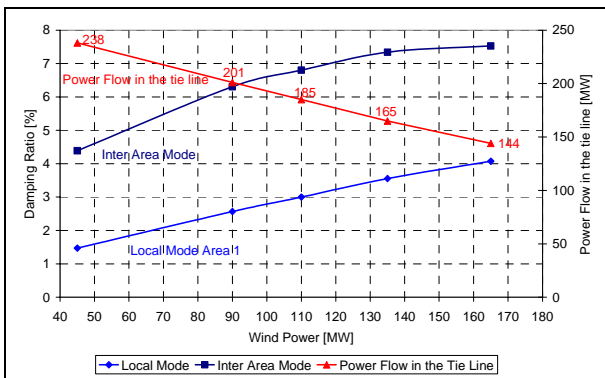

Figure 3: Configuration 4- Oscillation modes and power flow in the tie line between bus7 and bus8 as a function of the active power produced at the G1's terminals. 100 MVA rated asynchronous machine, contingency case with area 1 importing from area 2.

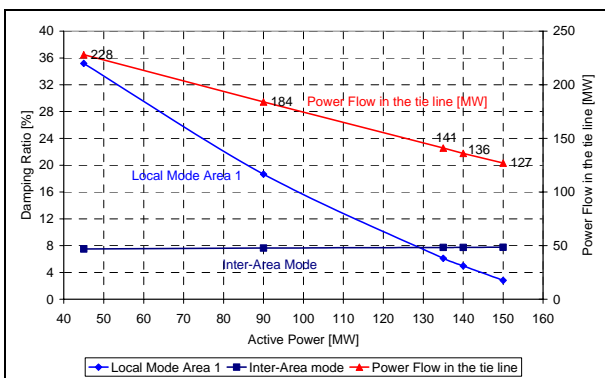

Figure 4: Configuration 1- Oscillation modes and power flow in the tie line between bus7 and bus8 as a function of the active power produced at G1's. 100 MVA rated synchronous machine, area 1 importing from area 2.

In Figure 5 the same analysis has been performed by doubling the MVA rating modelling the sizeable unit. In this case a different behaviour between configurations 3 with compensated asynchronous and configuration 1 with synchronous machine has become evident. The latter has worsened its damping ratio for more than 150 MW produced whereas the first has increased its

damping conditions of about 1 percentage point for any generation level (it varies between 9% and 10%). Furthermore the maximum power allowed with a synchronous generator is again restricted by the local mode in area 1, which becomes unstable over 300 MW power produced. The contingency scenario has also shown benefit from the augmented capacity in area 1, which means a wider margin of stable conditions, from 180 MW to 320 MW.

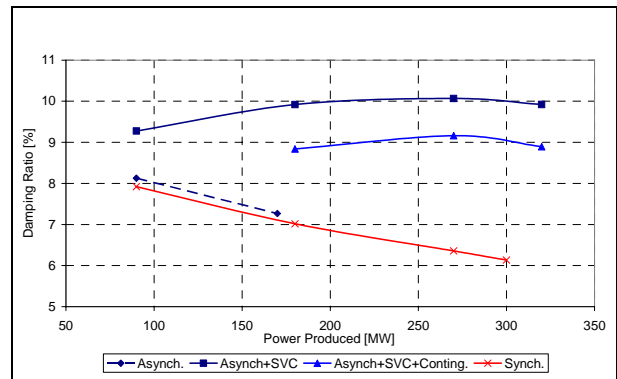

Figure 5: Damping ratio vs. power produced at the G1's terminals. 200 MVA rated machine, area 1 importing from area 2.

To summarize the result of the import scenario:

- Compensation through an SVC has improved the overall system damping.
- A tie line outage restricts the stable operative margins because of local oscillation issues
- Doubling the rating at generator G1, the benefits from SVC (in terms of oscillation damping) become more evident.

Area 1 exporting power to Area 2

This scenario may happen with favourable wind conditions while loads connected in the same area are low. To simulate this condition and hence to reverse the power flow in the tie line between area 1 and area 2, the load connected at bus 7 has been decreased from 967 MW to 567 MW. The configuration 2 has evinced a satisfactory damping ratio for any voltage stable point (Figure 6); but also a limit of 120 MW power produced as a result of the lack of reactive power support.

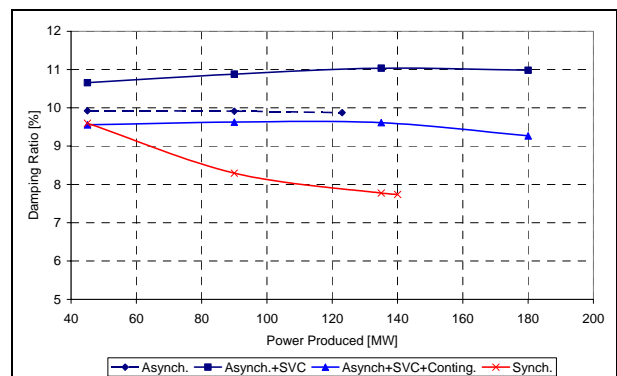

Figure 6: Damping ratio vs. power produced at the G1's terminals. 100 MVA rated machine, area 1 exporting to area 2.

The contingency on one tie line does not compromise the system stability; voltage stability is in fact achieved for any of the values in the range 45 MW – 180 MW power produced at the remote generation unit, with a damping ratio above 9%.

The solution with all synchronous generators shows the lowest damping and again local oscillations in area 1 become a concern for the system stability for more than 140 MW power produced.

In the exporting scenario the compensated wind farm with SVC again shows the best damping conditions (11%) for any voltage stable point, and a deeper wind power penetration compared to the configuration 1.

When we double the MVA equivalent rating for generator G1 (Figure 7), the different system behaviour acknowledged in the importing scenario has again found confirmation. The system can be operated with a contingency on the tie line with an adequate damping ratio of more than 10% in the whole range. Compensated asynchronous generator with SVC allows stable conditions up to 340 MW power produced against 300 MW achieved with synchronous generators. In addition the damping ratio has been satisfactorily stabilised to almost 12%.

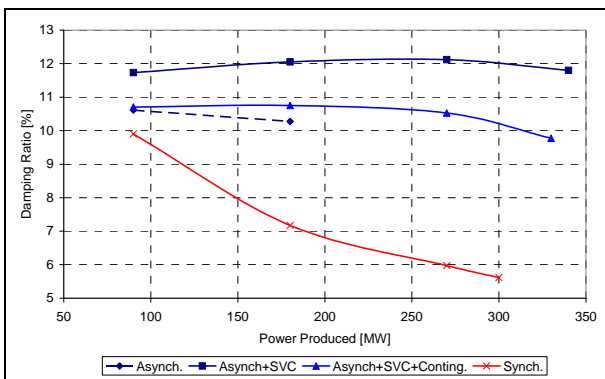

Figure 7: Damping ratio vs. power produced at the G1's terminals. 200 MVA rated machine, area 1 exporting to area 2

To summarize the results of the export scenario:

- Compensation through an SVC has improved the overall system damping.
- Doubling the rating at generator G1, the benefits (in terms of oscillation damping) from SVC becomes more evident.
- Local oscillations are an issue only for the configuration 1.

Effect of power system regulators on voltage stability limits

It is relevant to ask if changes in power system damping, e.g. caused by changes in power flow or stabilizer tuning, affect the voltage stability limits. In this section a parametric study has been performed to see the effect of different parameter and regulators on the voltage stability limits. A sensitivity analysis has been performed to establish the impact of the stabilizer's parameters on the eigenvalue corresponding to inter area mode and used to tune the PSS. The time

constant T4 in the stabiliser's block diagram (see APPENDIX 2), has shown to have the largest impact on the inter-area mode of oscillation and therefore has been chosen as tuned parameter.

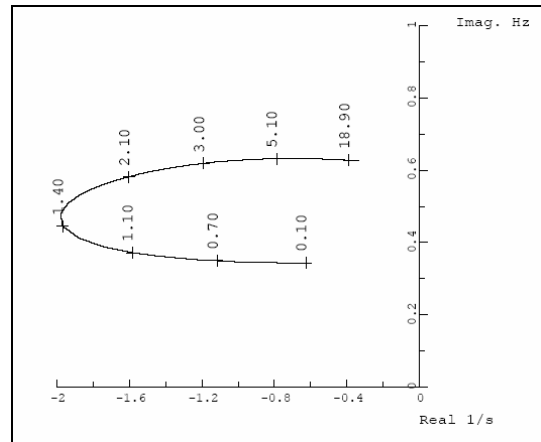

Figure 8: Root loci of the eigenvalue corresponding to the inter-area mode as affected by the PSS time constant T4. Curve parameterised with T4.

By tuning the PSS time constant T4, it has been possible to vary significantly the eigenvalue corresponding to the inter-area mode of oscillation and as a consequence modify the system stability level. Figure 8 shows the root loci of the eigenvalue corresponding to the inter-area mode as affected by the tuning of the time constant T4. In the analysis performed up to now T4 was set to 10 sec. Now in order to achieve better damping conditions the eigenvalue has been moved toward the left side of the negative complex half plane and set to 5.4 sec. The P-V curves for the two different PSS's time constants setting, and a worst case scenario without automatic voltage regulator (manual excitation control) shows that the tuning of the PSS does not affected the voltage stability limits (Figure 9).

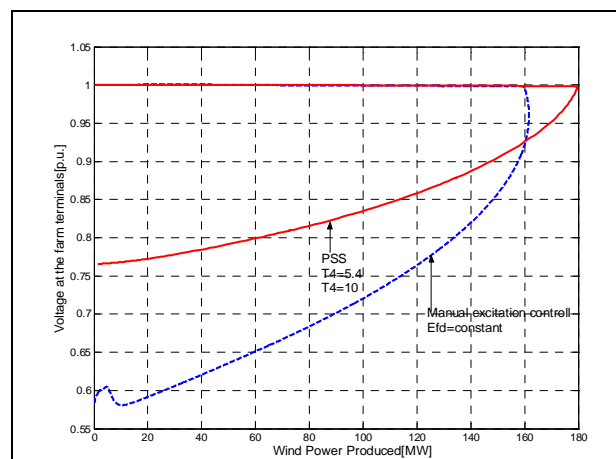

Figure 9: P-V curves with automatic voltage regulator and PSS (as affected by PSS tuning) and without voltage regulator (manual excitation control)

With the new time constant setting (T4=5.4 sec) the general damping conditions have improved for all the configurations analysed (Figure 10). We can now

operate the system with a damping above 15%. For configuration 1 the stable range is not affected by local mode of oscillation as it was before, allowing a stable operating range from 45 to 180 MW. Compensated asynchronous generator with SVC has still the best damping ratio, over 17%. The system is stable also in case of a contingency on the tie line, but shows a lower damping ratio (between 13% and 17%).

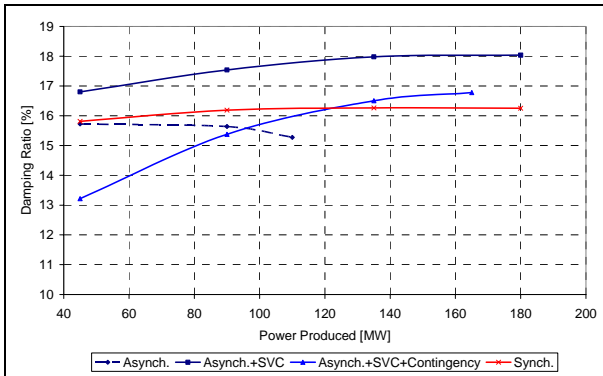

Figure 10: Damping ratio vs. power produced at the G1's terminals. 100 MVA rated machine. Import case T=5.4 sec.

As we increase the MVA rating at generator G1 the different behaviour between the configurations 1 and 3 becomes evident again (Figure 11). Compensated asynchronous generator with SVC has increased the damping ratio of 1 percentage point over the whole stable range, achieving an overall damping above 18%. With a contingency on one tie line the system can still operate stably with a damping above 16%. Again the solution with synchronous machines worsens its damping as the size of the machine G1 increases (below 16% in the whole stable range).

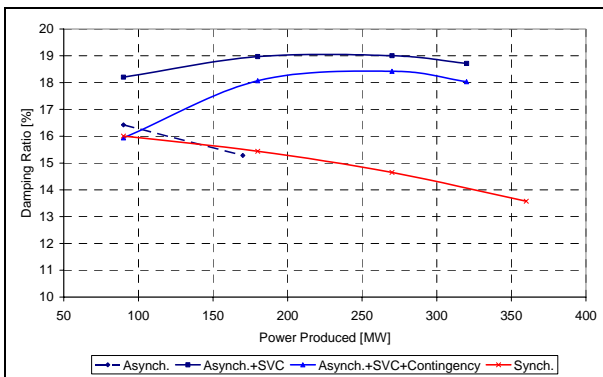

Figure 11: Damping ratio vs. power produced at the G1's terminals. 200 MVA rated machine. Import case T = 5.4 sec.

Also in the export scenario the new time constant setting has improved the overall system damping for both the MVA ratings (Figure 12 and Figure 13). Furthermore configuration 1 is not limited anymore by local oscillation modes.

To summarize the results of this paragraph, the new PSS tuning has brought the following benefits:

- The overall system damping has improved.

- The local mode of oscillation with the new tuning is not a concern anymore for none of the configuration and scenarios analysed.

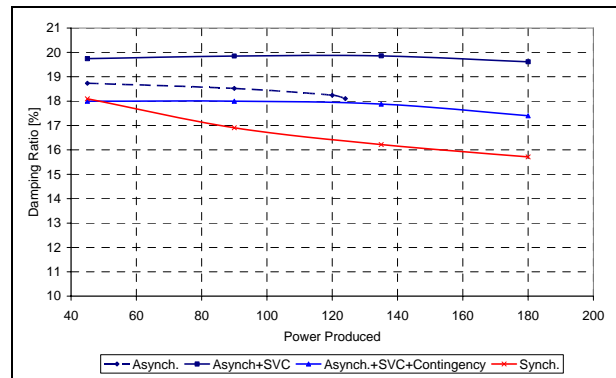

Figure 12: Damping ratio vs. power produced at the G1's terminals. 100 MVA rated machine export case T=5.4 sec.

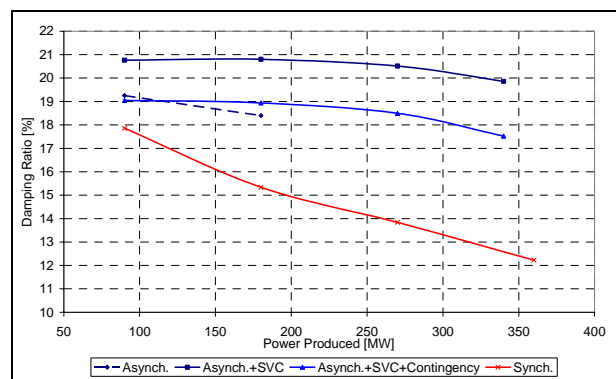

Figure 13: Damping ratio vs. power produced at the G1's terminals. 200 MVA rated machine export case T=5.4 sec.

4. DISCUSSION AND CONCLUSION

The objective of this study was to investigate possible correlations between voltage stability characteristics and damping of inter-area oscillations through the analyses of a simplified yet realistic two-area test system. The system used for our study, has been chosen because representative of a typical situation in which wind resources are located in remote areas connected to the main transmission network through a weak radial. Voltage stability and power system damping assessments have been performed as combined studies showing that voltage control and reactive power compensation through SVC's have a positive impact on system damping on the inter-area mode. The significance of the results is summarised in the following points:

- A traditional induction generator compensated through an SVC, improves the overall system damping for both 100 MVA and 200 MVA ratings. In particular the 200 MVA rated case has shown better damping for both the import and export scenario.
- The system shows a different behaviour between the configuration with synchronous and asynchronous machines. In particular, the inter-area mode becomes more stable as the real power produced at the wind

farm and the size of the farm increases. The opposite appears for the system configuration with only synchronous machines.

- With a synchronous generator as the weakly connected unit, the local power oscillation in area 1 can be the limiting factor in relation to the power produced from the generator G1 (upper limit of the stable system range). The local mode becomes, in the circumstances of high level of power produced at the remote unit, the main concern for the system stability. This can be attributed to the lack of synchronizing torque, making the system unstable for high power transfer levels between the weak radial. The higher the power produced, the higher the local oscillations.
- The mixed generation solution in area 1, with both synchronous and asynchronous generators, has shown better damping of the inter-area mode and has allowed a higher power level transmitted through the radial. The local modes in this case are not a main concern. In a contingency scenario, local mode can affect the lower limit of the system stable range. The high power transferred from area 2 to area 1 in this case is responsible for the system instability. As soon as we discharge the tie line between the two areas by increasing the production at the wind farm, we bring the system toward stable conditions. The lower the power produced, the higher the power transferred and therefore the higher the local oscillations.
- Changes in power system damping, caused by stabilizer tuning, do not affect the voltage stability limits. Sensitivity analysis on the eigenvalue corresponding to the inter-area mode, has allowed an optimal tuning of the regulator parameters.

5. APPENDIX 1

A table with eigenvalues and eigenvectors representation (in the complex plane) for configuration 1 in the importing scenario follows to show the participation of the machine in the oscillation dynamic. The equivalent generator G1 is a 100 MVA rated machine.

Eigen value		
Real Part [1/s]	Immaginary Part [Hz]	Mode
-2.6333	0.97833	Local oscillation Area 1
-1.4106	1.1938	Local oscillation Area 2
-0.60895	0.59795	Inter-Area oscillation

Table 1 Eigenvalues for the configuration, import case.

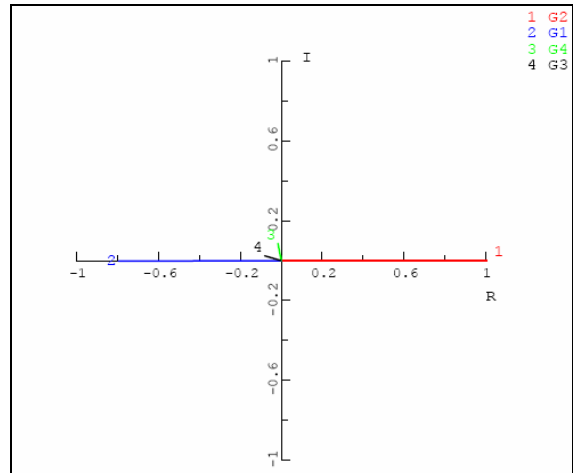

Figure 14 Local mode of oscillation in area 1 corresponding to the eigenvalue $-2.63326, +j0.978334$ Hz.

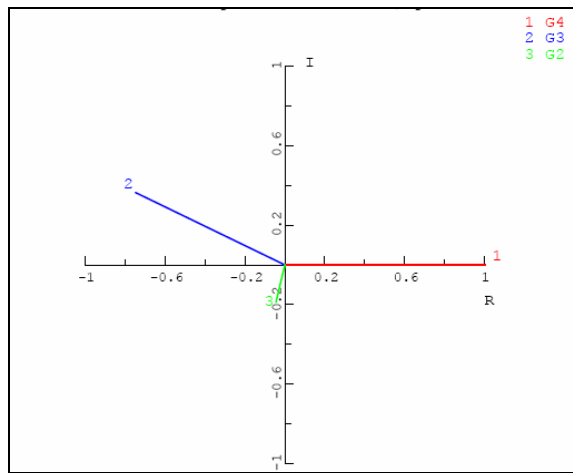

Figure 15: Local mode of oscillation in area 2 corresponding to the eigenvalue $1.41062, +j1.19376$ Hz.

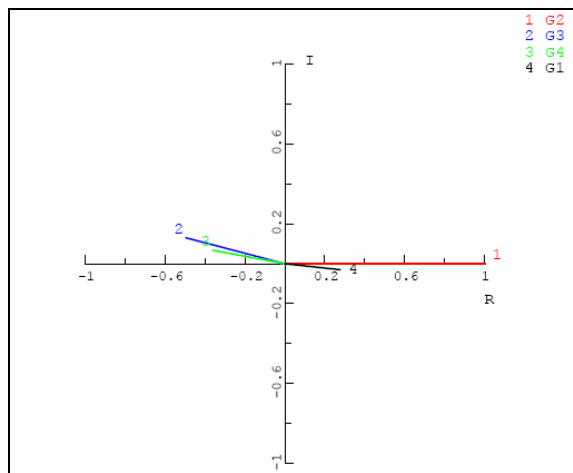

Figure 16: Inter-area mode of oscillation between area 1 and area 2 corresponding to the eigenvalue $-0.608954, +j0.597950$ Hz.

6. APPENDIX 2

A description of the PSS bloc diagram is given in this appendix:

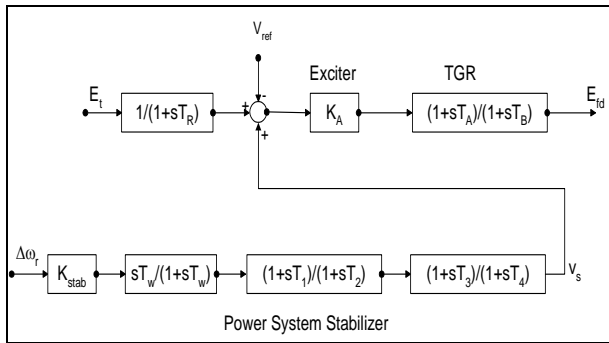

Figure 17 Power System Stabilizer (PSS) block diagram. $K_{STAB}=20$; $T_w=10$; $T_1=0.05$; $T_2=0.02$; $T_3=3$; $T_4=5.4$;

7. REFERENCES

- [1] M. P. Palsson, T. Toftevaag, K. Uhlen, and J. O. G. Tande, "Large-scale wind power integration and voltage stability limits in regional networks," presented at Power Engineering Society Summer Meeting, 2002 IEEE, 2002.
- [2] Sanchez-Gasca, "A modal analysis of a two-area system with significant wind power penetration," presented at Power Systems Conference and Exposition (PSCE'04), New York from 10 - 13 October 2004, 2004.
- [3] P. Kundur, *Power system stability and control*. New York: McGraw-Hill.
- [4] ABB, "Simpow," 10.2 revision 080, January 13, 2004.
- [5] C. W. Taylor, "Power system voltage stability," N. J. Balu and D. Maratukulam, Eds. New York: McGraw-Hill.