

A STORAGE MANAGEMENT ALGORITHM FOR IMPROVED WIND GENERATOR PERFORMANCE

Chad Abbey
McGill University
Montréal, Canada
cabbey@po-box.mcgill.ca

Géza Joos
McGill University
Montréal, Canada
joos@ece.mcgill.ca

Abstract – Energy storage has been proposed as a potential solution to counter the short-term variations of wind, thereby providing a more stable output power from wind generators. This paper presents a fuzzy logic based energy management structure for a doubly-fed induction machine based wind generator with an integrated energy storage system. The energy management algorithm compensates for limitations in the storage device by considering the level of stored energy, operating conditions of the generator, and the local wind conditions in order to help smooth the output power of the generator. The performance of the system is compared with conventional technologies and other alternatives to demonstrate the added benefits. The results illustrate that the addition of storage enables a more effective use of the available energy and can provide multiple benefits to wind generator systems.

Keywords: wind energy, doubly-fed induction generator, energy storage, fuzzy logic

1 NOMENCLATURE

b_i	Degree of fulfillment for i^{th} rule
c_i	Consequent for i^{th} rule
E_{ess}	Energy of energy storage device
P_{conv}	Rectifier power
P_{grid}	Wind power delivered to the grid
$P_{grid,ref}$	Wind power reference
$\Delta P_{grid,ref}$	Change in wind power reference
P_s	Stator power
V_{pcc}	Voltage at point of connection
β	Pitch angle
ω_m	Mechanical angular speed

2 INTRODUCTION

Recently many utilities in both North America and Europe have sponsored studies on wind energy, many of which have focused in particular on the interconnection issues associated with integrating large amounts of wind production to their systems. All technical aspects associated with the effect of wind on the power system have been considered including: effects on power quality, reactive power needs and voltage control, as well as stability [1], [2]. As a result of these studies, many utilities as well as governments and/or regulatory bodies have either generated interconnection requirements aimed specifically at new wind projects or have revised existing codes to include specific elements which must be satisfied by new projects. The stricter requirements

have forced manufacturers to modify their designs in order to meet these new needs.

This change is a direct result of wind reaching high penetration levels in various jurisdictions. Whereas at low levels of penetration the shortcomings of wind are more or less negligible, these factors play an important role at high levels of integrated wind and therefore, extra precautions are imposed in order to maintain the same standard of service. Technically this requires modifications to traditional wind park designs, in the form of added equipment, implementation of modern wind turbine technologies, sophisticated prediction and control strategies, or a combination of the above. The design modifications will depend largely on the interconnection requirements in question, the local network, as well as the geographical location and size of the wind park.

Utility interconnection requirements for wind parks can be summarized into four separate issues: reactive power and voltage control, low-voltage ride through (LVRT) capability, power quality, and to a lesser degree power control and management. While the first three have been well addressed and appropriate modifications to turbines or the wind park have been implemented, the latter remains unresolved with no clear solution presenting itself. While complementing wind with firmer fast-acting hydro generation may be realistic and economically feasible, it is not always possible, either due to the location of the wind park in relation to the hydro or due to low reservoir levels. Likewise energy trading agreements that permit countries such as Denmark to manage high local levels of wind are not always practical in certain areas such as in Spain due to the lack of the necessary inertias, [2]. Energy storage options have been proposed in certain cases, however, the cost of many of the technologies has not yet reached a level that makes them competitive with other alternatives.

This paper proposes an energy management system, which is incorporated into a wind powered doubly-fed induction generator (DFIG) and energy storage design. The management system dispatches the output power of the generator based upon local measurements and prediction of average wind speeds and power output. The system enables a reduction in the output power fluctuations of the generator, permits LVRT capability, and improves the transient response following faults, while ensuring that the storage limits are not reached. A brief review of the issues facing wind is presented along with

the competing wind generator technologies. This is followed by the outline of the wind energy system and the associated energy management algorithm. The system characteristics are then presented and are compared to other wind generator systems in order to highlight the advantages.

3 BACKGROUND

Here the background information on the current wind turbine generator (WTG) options, interconnection issues, and storage technologies are presented. This serves as a review of the important issues and justifies the investigation of coupling energy storage systems with wind generation.

3.1 Wind Energy Systems

Variable speed wind generators are more commonly used, as they are capable of higher energy capture, lower mechanical stresses, more constant output power, and reduced noise compared with fixed speed machines, [3]. Direct drive technology using high pole permanent magnet synchronous generators (PMSM) are capable of variable speed operation, where the generator is connected to the system using either a back-to-back voltage source converter (VSC) or a diode rectifier with a VSC to interface with the grid. The doubly-fed induction generator (DFIG) is another common variable speed topology which utilizes wound-rotor induction machines with an ac-dc-ac converter between the stator and rotor terminals. The most common wind generator arrangements are shown in Figure 1.

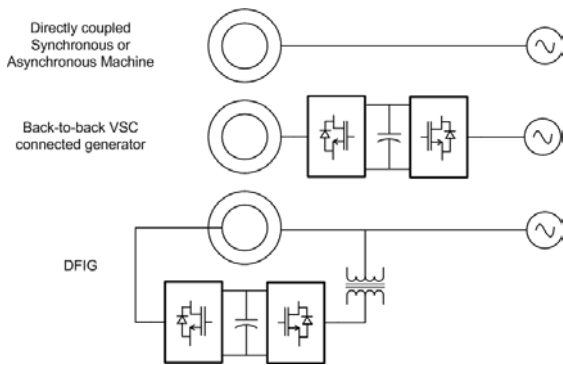

Figure 1: Wind generator technologies

3.2 Interconnection Issues

As previously mentioned, a large number of wind generators rely upon asynchronous machines. Consequently, one of the primary requirements imposed by utilities is that the wind park be able to control its power factor within a preset range and in many cases actively participate in voltage support. Variable speed generators possess this ability due to the existence of power electronics while for directly coupled machines, reactive compensation is supplied from an external source.

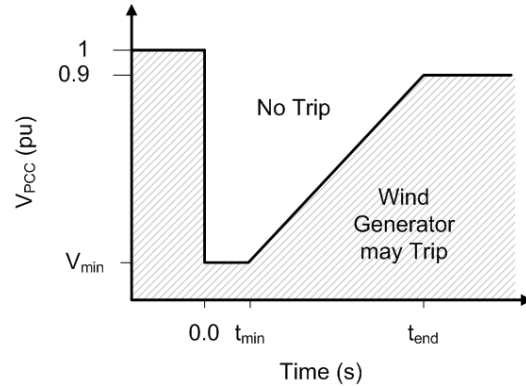

Figure 2: LVRT characteristic

LVRT capability is particularly important for large installations, which are connected to weak points in the network. A typical LVRT characteristic is shown in Figure 2. The characteristic is more or less defined by a minimum voltage throughout the duration of the fault followed by a ramping up to nominal level as the voltage recovers. The width of this minimum will vary depending on the code but may be as long as 625 ms (E.ON LVRT, [5]). The characteristic then ramps up to the normal operating range with a given slope. Wind generators must respect the characteristic and remain connected for all normally cleared faults and support the system.

The functional operation of LVRT is based on the comparison of the characteristic with that of the terminal voltage. Essentially once the voltage deviates outside of the normal operating range the control system then compares the recovery of the fault with that of the minimum voltage level as given by the LVRT characteristic. In the case in which the voltage falls below that of the LVRT characteristic, the generator may trip, however, anywhere above the minimum, the generator must remain connected and support the grid.

In terms of practical realisation of the LVRT characteristic, the doubly-fed induction generator poses the greatest challenge during a low voltage as a result of the machine being coupled to the grid in addition to the presence of sensitive power electronics. During a voltage dip the induction machine will contribute an elevated current to the fault for a short period of time. Due to the connection of the rotor terminals to the converter, the fault current is reflected on the rotor side and will be fed to the converter unless it is bypassed by a crowbar circuit, [4]. In the absence of the crowbar circuit, the dc bus voltage will typically rise due to the inability to carry the excess power across the bridge to the grid. In addition, the machine will tend to accelerate since there is a mismatch between the power delivered to the grid and the mechanical input power. Alternatively, an energy storage device could be placed on the dc bus in order to store the energy supplied from the machine and hold the dc bus voltage constant. This modification does however require derated rotor side converters in order to carry the elevated currents during the fault.

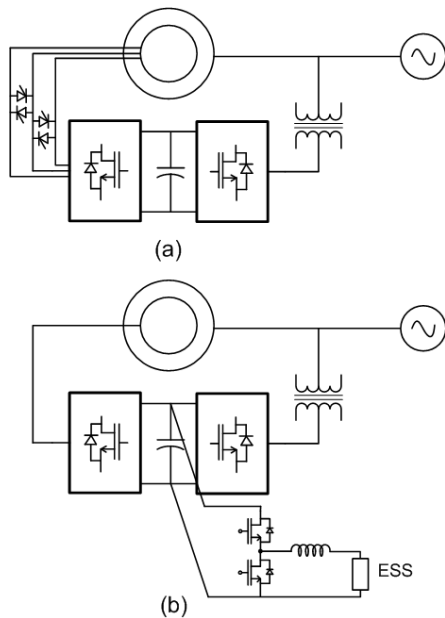

Figure 3: Possible realisations of LVRT characteristic in doubly-fed induction generator

Power quality requirements are included in many codes but are generally more common in the case of connection of wind to distribution systems. Issues include: effect of wind on harmonics, voltage flicker, and fast voltage fluctuations. Various studies have been performed on the connection of wind at the distribution level, [3].

Interconnection requirements have also begun to place stipulations on the control of the output power of the wind park itself. Although this trend has not yet become widespread, the fact that wind generators will inevitably be required to behave in a manner analogous to conventional generators is a strong possibility. While pairing wind installations with hydro reserves, improved prediction techniques, and energy trading promise to be viable solution options, the integration of energy storage devices into the design has been considered and has proved to be technically effective in limiting the variability due to the wind, [6], [7]. Alternatively the inertia of the machine can be used to smooth out short-term variations in some cases.

3.3 Energy Storage Technologies

A wide range of storage options are currently available with each occupying a particular area of application. In selecting the type of storage device for a given need both the power rating and energy rating of the device must be considered. While certain technologies are preferable for one application, they are likely not suitable in other cases. For instance, both flywheels and superconducting magnetic energy storage systems are well adapted for providing short burst of high power, making them suitable for voltage recover applications, however, they are not well suited for longer term storage of large amounts of energy as is in the cases of arbitrage and balancing services. For reduction of the

power fluctuations due to the variability of wind, the most relevant technologies are batteries, supercapacitors, and pumped hydro storage. In applications where the wind park is not located in or close to an area geologically favorable for pump storage, the choice is limited to the electrochemical options.

4 WIND GENERATOR SYSTEM

This section presents the doubly-fed induction generator system, energy storage integration based upon supercapacitors, and energy management algorithm. This system serves as an example of the application of the proposed strategy.

4.1 Doubly-fed Induction Generator (DFIG)

The DFIG is one of the most common variable-speed generators that are presently used. The generator uses a wound-rotor induction machine where the rotor terminals are fed via a back-to-back voltage source converter (VSC). The control consists of two separate algorithms, which control the rotor and stator-side converters. The rotor converter is controlled in order to set the speed of the generator and stator reactive power, while the supply-side converter functions mainly as a dc bus regulator but may also be used to supply reactive power if necessary. The details of the control are very well documented and can be found in [7], [9] among others.

4.2 Energy Storage System

The design of the DFIG can be modified by the addition of an energy storage device, which is connected to the dc bus through a 2-quadrant dc/dc chopper. In this case the control of the dc bus voltage is transferred to the chopper while the supply side converter is controlled in order to regulate the power delivered to the grid to a set value. The control algorithm must be modified in order to account for this difference in strategy but it must also take into consideration the case where the storage device reaches either its upper or lower limit, in which case, control must be transferred back to the conventional case, as detailed in [7]. While the previous work considered the control of the system, the focus here is on the development of a management algorithm in order to extend the range of operation of the system.

Here the storage device was sized such that it would be capable of storing the full rating of the system during the entire low voltage condition as given in the LVRT requirement in [5]. As the machine would still be capable of supplying power during this period, this is somewhat conservative however serves as a reasonable starting point.

4.3 Storage Management Algorithm

In its simplest form the power of the DFIG and ESS hybrid is dispatched in order to supply a set amount of power. However, this assumes that the state of operation of the generator is always relatively near that of the set point and neglects the current limitations of the different converters. Furthermore, the benefits of the storage

device are not completely taken advantage of, particularly when there is a large mismatch between the set point power and the output of the machine. In the case of a wind generator, the operating point is sure to change since it is tied to the local environmental conditions. By allowing the set point to vary the time scale over which the storage device can be applied is extended, thereby maximizing the benefits of the storage while relinquishing only slightly the firm regulation of the output power. Through proper design of the management system, the storage device can be kept in operation by curtailing the power reference near the storage limitation of the device.

However, setting of the power reference in order to ensure that the ESS remains in operation is difficult since it is not known exactly how it should vary. Wind predictions algorithms, although somewhat imprecise are prone to inaccuracies and furthermore the relationship to output power is not precisely known either. The need to cover normal operation, limiting conditions, as well as transient behavior of the system makes this control even more difficult. Fuzzy rule based systems have been shown to be effective in various power systems problems [10]-[12] and are well suited to the present system. Using the predicted wind power production, energy storage device status, and ac voltage measurements, a fuzzy based energy management system can be used to set the power level in order optimize the operation of the system.

Table 1: Rule base for energy management algorithm

1	If E_{ess} is small then ΔP_{grid} large.
2	If E_{ess} is small-medium then ΔP_{grid} small.
3	If E_{ess} is medium then ΔP_{grid} is zero.
4	If E_{ess} is medium-big then ΔP_{grid} small.
5	If E_{ess} is big then ΔP_{grid} large.
6*	If V_{pcc} is small then ΔP_{grid} small.
7	If V_{pcc} small then β large.

*Three realizations of this rule were investigated: small, unchanged and large.

The rule base was developed in order to attempt to balance the needs to smooth the output fluctuations, reduce the output power during fault condition, and ensuring that the storage device remains in operation all times. In essence, the initial set point is determined using the predicted power output during the interval of interest, which is provided by a prediction method. This reference value is modified by the algorithm to ensure that there is always some base amount of energy storage in the device and likewise that there is always a certain threshold below the upper limit.

For the transient component of the control, a number of variations were studied using the measured voltage magnitude is monitored. In the event of a voltage sag, the algorithm was set to either reduce, increase, or to not affect the reference power. This series of tests was attempted in order to determine the effect that it may have on the ability of the system to help improve the

recovery of the system voltage. Together the normal and transient functions of the management system were designed to help smooth the output power, ensure the storage device remains in operation, and to provide LVRT.

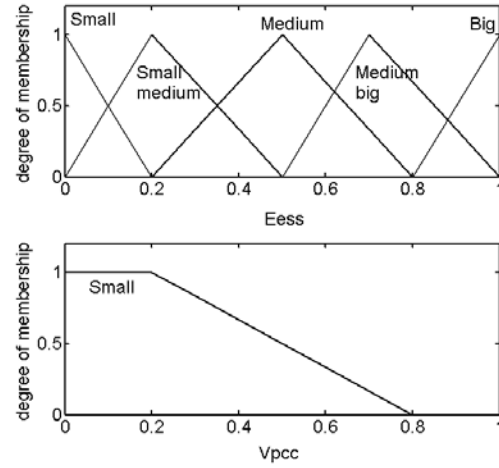

Figure 4: Membership functions for stored energy, E_{ess} , and the voltage at point of common coupling, V_{pcc} .

The rules were implemented following standard fuzzy logic techniques. Following fuzzification, each of the rules was fired through combination of the fuzzy sets using the fuzzy equivalents of AND and NOT, i.e.:

$$AND(\mu_x, \mu_y) = \min(\mu_x, \mu_y) \quad (1)$$

$$NOT(\mu_x) = 1 - \mu_x \quad (2)$$

Inference and aggregation of the rules was then used in order to produce the final value for the reference power, a value between 0 and 1, which is then converted to a reference value using the base power. The weighting of the various rules is most easily represented by the following:

$$\Delta P_{grid,ref} = \frac{\sum_{i=1}^K b_i c_i}{\sum_{i=1}^K b_i} \quad (3)$$

Where K is the number of rules and b_i and c_i are the degree of fulfillment and consequent of the i^{th} rule, respectively. The consequents for each of the rules in Table 1 are given in Table 2 below. As can be noted the values for rules 1 and 2 are negative which makes $\Delta P_{grid,ref}$ negative and thus has the effect of decreasing $P_{grid,ref}$.

Table 2: Consequents for determination of $\Delta P_{grid,ref}$

Rule	1	2	3	4	5	6*
c_i	-0.6	-0.2	0	0.2	0.6	0.2

*Here c_6 took values of 0.2, 0, and -0.2

The final reference power, $P_{grid,ref}$ that is inevitably sent to the converter control, is obtained by the sum of the change in the reference value, as determined by the management algorithm and the estimated turbine power as predicted by the wind speed and power prediction algorithm.

$$P_{grid,ref} = P_{grid,pred} + \Delta P_{grid} \quad (4)$$

As β is a result of only one rule it simply has the effect of increasing the pitch angle during a low voltage event, which helps to limit the input torque during a local system fault.

5 SYSTEM CHARACTERISTICS

The models were developed using the new electromagnetic transient programming (EMTP) as described in [13],[14]. Using the developed models both normal operating characteristics as well as response to disturbances was obtained using the same platform. The medium voltage interconnection of the wind generator was modeled using a network equivalent and load models as shown in Figure 5.

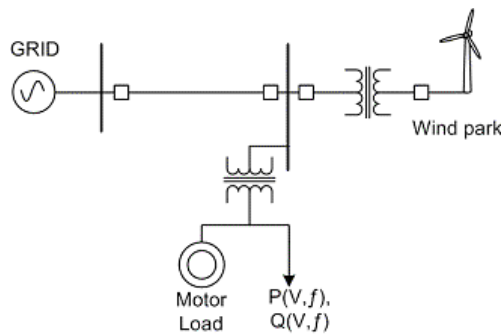

Figure 5: Interconnection of wind energy to medium voltage transmission network used for system studies.

5.1 Normal operating conditions

The operation of the storage management scheme is shown in Figure 6, where the power supplied from the stator of the machine, the converter and that supplied to the grid are shown. As well the evolution of the wind speed over the time range considered can be compared with the output power, along with the level of storage in the device. It can be noted that the supply side converter is able to absorb the high frequency fluctuations of the wind.

The benefits of the storage management scheme were also compared with other available technologies. The conventional WTG and a conventional DFIG implementing the power smoothing technique as described in [8] were run along with the DFIG with energy storage, implementing the proposed management scheme, Figure 7. As well the average power obtained using a con-

ventional WTG with maximum power point tracking (MPPT) is shown as the base case.

As expected, the DFIG without energy storage is subject to much greater power oscillations. In the second case, the strategy of smoothing the output power by operation at suboptimal power points proves to be quite useful in regulating the output power. The main cost is of course a reduction of efficiency, where the loss of energy is the difference between that output power and the average power using MPPT. As well, the usefulness at higher wind speeds requires further investigation since there is an upper speed limit on the machine that must be respected.

Using the proposed method, the DFIG with storage is able to maintain a relatively smooth output power over the entire time period. The short-term fluctuations are virtually eliminated while the slow variation persists as the algorithm accounts for the limitations of the device. The variation in the output power is effectively reduced although it still changes slightly over the interval. It may be that the algorithm could be optimized in order to push the storage to its further to its limits, however would leave one susceptible to errors in power prediction. Also compared with the power smoothing algorithm the power at a given moment is much less volatile due to the fast acting ability of the power electronics to schedule the required power slack whereas in the former case, the power smoothing is based upon tracking the appropriate suboptimal points and is therefore slower due to the large time constant of the combined turbine and blade system.

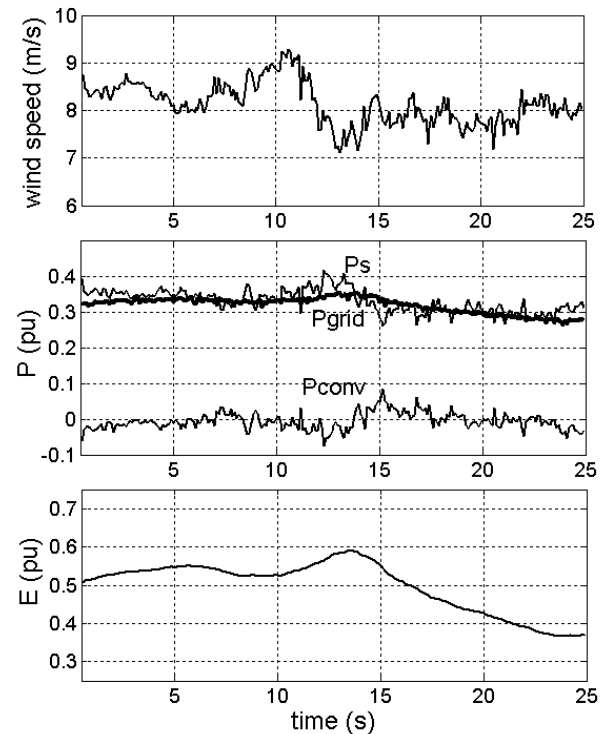

Figure 6: Normal operation showing (a) wind speed, (b) generator output power and (c) storage level for ESS.

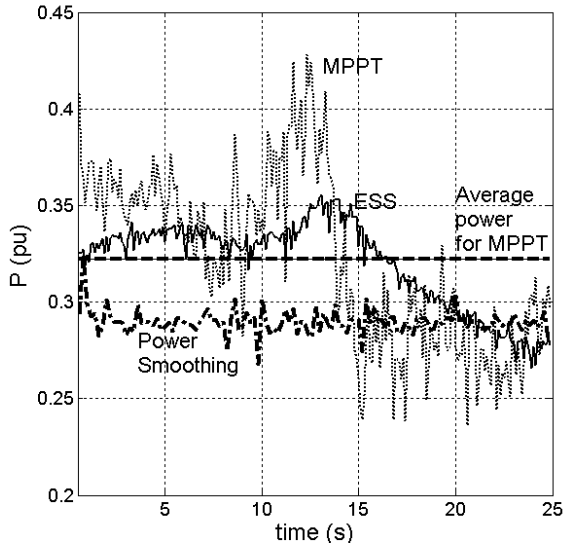

Figure 7: Grid power for (a) DFIG operating with MPPT algorithm, (b) DFIG with ESS operating using proposed algorithm and (c) DFIG operating with power smoothing algorithm.

5.2 Transient Operation

The response of the system following a 12 cycle two-phase fault was obtained for a DFIG using active crowbar and for the DFIG-ESS using the three different voltage signals, i.e. power boost, power curtailed and unchanged. The fault is applied at the midpoint of the transmission line at 1.6 s and is cleared 200 ms later. The curves for the voltage magnitude at the PCC, Figure 8, wind farm reactive power, Figure 9, and slip for both the generators and the local motor loads, Figure 10 were obtained

In the first case, the conventional DFIG, the machine has been modeled such that it has been equipped with active crowbar capability, whereby the rotor terminals are short-circuited during the fault and the converter gating signals are blocked, and therefore emulates a conventional induction generator throughout the duration of the fault. In the second case, the storage provides the ride through capability for the generator by limiting the overvoltage on the dc link. As mentioned three different signals were considered for the transient component of the storage algorithm: i) curtailing of the power reference, ii) P_{ref} unchanged, and increasing of the power references in response to a voltage sag. An interconnection with a short circuit ratio (SCR) of 3 was considered in order to represent a weak system.

The energy storage solution proves superior in the case of limiting the overspeed, which would be even more evident for longer fault durations. This is primarily due to the ability to hold the dc voltage and support the ac system. As can be noted the voltage drop does not continue following initiation of the fault, due to the ability to supply the magnetizing current to the machine and maintain its internal voltage. In contrast, the voltage in the case of the DFIG with crowbar continues to fall

and only reestablishes following return of the ac system. For longer fault durations complete loss of the generators is inevitable. The reactive power demand is high following fault clearing as a result of saturation of the voltage controllers and the need to supply the reactive currents of the magnetizing branch.

When considering the influence of the different voltage signals in the management scheme for the ESS it can be noted that curtailing of real power during the fault results in slightly reduced performance, suggesting that the power reference should in fact be either boosted or left unchanged following voltage drops. This leads one to conclude that in fact the presence of stored energy not only aids in support of the dc voltage control but of the ac system behavior as well. Supply of power during and subsequent to a disturbance may aid one in limiting the depth of the voltage drop and shaping the recovery of the local voltage following fault clearing.

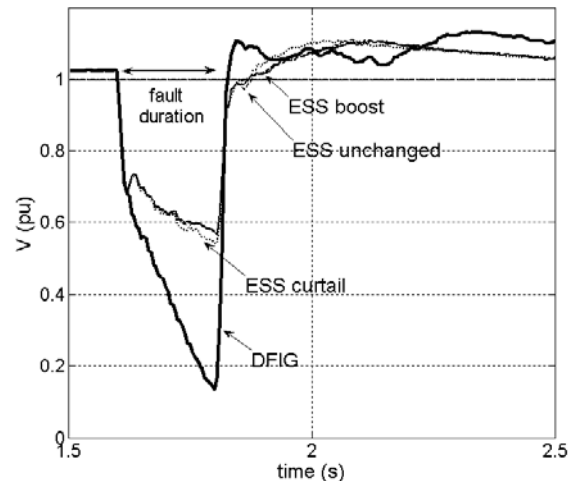

Figure 8: Response of voltage magnitude at PCC for (a) crowbar, (b) ESS – power boost, (c) ESS – curtailed power, and (d) ESS – P no change. SCR = 3, 12 cycle two-phase fault (1.6 to 1.8 s).

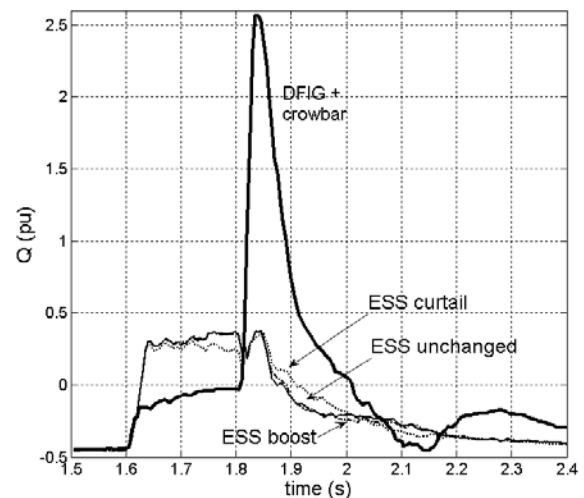

Figure 9: Reactive power delivered during two-phase, 12 cycle fault (1.6 to 1.8 s) for four cases.

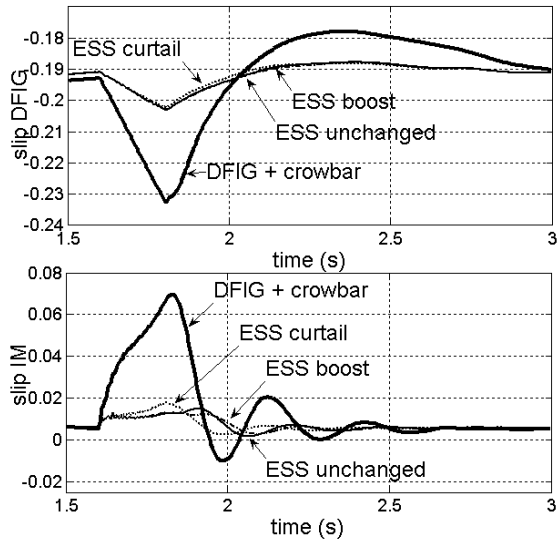

Figure 10: Response of generator (top) and motor load (bottom) slips during two phase, 12 cycle fault (1.6 to 1.8 s) for four cases.

6 CONCLUSION

This paper has proposed an algorithm for energy management of a storage device integrated into the design of a wind generator. The system was compared with a conventional WTG with MPPT algorithm as well as against power smoothing operation using suboptimal power points and demonstrated superior performance both in terms of regular operation and in response to transients. Results show that this system offers improvements over conventional WTG on the basis of smoother output power and improved voltage support and recovery following voltage drops. While power smoothing using operation at suboptimal points offers similar benefits in terms of reduction of power fluctuations it is unable to provide the same improvements in transient stability that the ESS offers. Furthermore the method has reduced efficiency and requires a wider speed range. Overall, the WTG-ESS offers good improvements in power quality and also provides greater flexibility to shape the recovery of the voltage following transients.

REFERENCES

- [1] Bolik, S. M., "Grid requirements challenges for wind turbines", Fourth International Workshop on Large Scale Integration of Wind Power and Transmission Networks for Offshore Wind Farms, Oct. 2003.
- [2] Electric Systems Consulting, ABB Inc., "Integration of Wind Energy into the Alberta Electric System", prepared for the Alberta Electric System Operator, <http://www.aeso.ca/market/6389.html>.
- [3] Bossanyi, E., Z. Saad-saoud, and N. Jenkins, "Prediction of flicker produced by wind turbines", *Wind Energy*, Vol. 1, Issue 1, pp. 35-51, 1998.
- [4] Niiranen, J., "Voltage ride through of a doubly-fed generator equipped with an active crowbar", Nordic Wind Power Conf., Chalmers University of Technology, March 2004.
- [5] E. ON Netz GmbH, "Grid code for high and extra high voltage", Bayreuth, Germany, August 2003, www.eon-netz.com.
- [6] Enslin, J.H.R., J. Knijp, C.P.J. Jansen, and P. Bauer, "Integrated approach to network stability and wind energy technology for on-shore and offshore applications", *Power Quality Proceedings*, pp. 185-192, May 2003.
- [7] Abbey, C., and G. Joos, "A doubly-fed induction machine and energy storage system for wind power applications", IEEE PESC 2004, Aachen, Germany, July 2004.
- [8] Ran, L., J.R. Bumby, and P.J. Tavner, "Use of turbine inertia for power smoothing of wind turbines with a DFIG", 11th International Conference on Harmonics and Quality of Power, pp. 106-111, Sept. 2004.
- [9] Datta, R. and V. T. Ranganathan, "Variable-speed wind power generation using doubly fed wound rotor induction machine – a comparison with alternative schemes," *IEEE Trans. Energy Conv.*, Vol. 17, No. 3, Sept, 2002
- [10] Marques, A. B., G. N. Taranto, and D. M. Falcao, "A knowledge-based system for supervision and control of regional voltage profile and security", *IEEE Trans. Power Sys.*, Vol. 20, Issue 1, pp. 400-407, Feb. 2005.
- [11] Pandiaraj, K., P. Taylor, N. Jenkins, and C. Robb, "Distributed load control of autonomous renewable energy systems", *IEEE Trans. Energy Conv.*, Vol. 16, No. 1, March 2001.
- [12] Schouten, N. J., M. A. Salman, and N. A. Kheir, "Fuzzy logic control for parallel hybrid vehicles", *IEEE Trans. Control Sys. Tech.*, Vol. 10, No. 3, May 2002.
- [13] Mahseredjian, J., L. Dubé, and L. Gérin-Lajoie, "New Advances in the Simulation of Transients with EMTP: Computation and visualization Techniques". Proceedings of 7th International conference on Modeling and Simulation of Electric Machines, Converters and Systems, Montreal, August 18-21, 2002.
- [14] Mahseredjian, J., S. Dennerrière, L. Dubé, B. Khodabakhchian and L. Gérin-Lajoie, "On a new approach for the simulation of transients in power systems", IPST 2005, Montréal, June 19-23, 2005.