

# PERFORMANCE VERIFICATION OF TCSC CONTROL AND PROTECTION EQUIPMENT USING RTDS

Arunachalam, M; Ghamandi Lal; Rajiv C G;  
Bharat Heavy Electricals Limited (BHEL), Electronics Division, Bangalore, India  
and  
Babu Narayanan MM  
Central Power Research Institute (CPRI), Bangalore, India

**Abstract** – This paper describes the evaluation of the performance of the controller developed by Bharat Heavy Electricals Limited (BHEL) for Thyristor Controlled Series Capacitor (TCSC) using Real Time Digital Simulator (RTDS). The TCSC controller was developed for the Kanpur-Ballabgarh 400kV single circuit ac transmission line located in North India. It is designed to perform important functions like impedance control, current control in the line and damping of power swing oscillation caused by system disturbances. It also reduces the stress on Metal Oxide Varistor (MOV) during faults and protects the capacitor against overvoltage and the Thyristor Controlled Reactor (TCR) against over current. The control system block diagram scheme has been arrived at after rigorous digital simulation studies in MATLAB. The developed scheme is implemented in the control panel using high-speed processor based hardware. TCSC controller was interfaced to RTDS and studies were performed in stages. Initially, a simplified circuit consisting of Kanpur-Ballabgarh line with both ends represented by Thevenin equivalent source and impedance was considered. The transient response of the controller was studied for step changes in TCSC impedance and line current. In the second phase of the studies, the northern region power system was represented and various contingencies were simulated. The performance of the controller in damping the power swing oscillation in the Kanpur-Ballabgarh line was demonstrated.

Some of the important results of RTDS studies have been compared with the MATLAB digital simulation results. Both the results were in close concurrence.

**Keywords:** TCSC, RTDS, and TCR

## 1 INTRODUCTION

In India the demand for electrical power is increasing at a rapid pace and it is becoming important to make the transmission system more effective. Flexible AC Transmission Systems (FACTS) are being employed more and more in present scenario to enhance the capability of the transmission system. TCSC is an important FACTS device that enhances the power delivery capability and improves the system stability. India's first series compensation scheme on 400KV ac line is installed at Ballabgarh substation of Power Grid Corporation of India Limited (PGCIL) on the Kanpur-Ballabgarh 400km long single circuit ac line. The project is implemented in two phases. In phase-I, Fixed Series Compensation (FSC) has been installed. The

FSC consists of two capacitor banks of 27% and 8% providing 35% compensation to the line. The FSC scheme is already in operation. In phase-II, the 8% compensation is made variable up to 20% by TCSC, which is formed by parallel connection of TCR. The variable portion of the phase-II was test commissioned recently and is in the process of being put into continuous operation.

Thyristor valves and control system for TCSC are developed at Electronic Division, BHEL, Bangalore, India. The control system philosophy is developed in association with Indian Institute of Technology (IIT), Mumbai, India. The control system block diagram scheme has been arrived at after rigorous digital simulation studies in MATLAB. The developed scheme is implemented in the control panel using high-speed processor based hardware. As the controller is being developed for the first time, the system very complex and the limited time to commission the system made it imperative to test and tune the controller using a real time simulator. The RTDS at Central Power Research Institute (CPRI), Bangalore, was used to carry out this performance verification studies and tuning of the controller as per IEEE standards [1].

After production checks at BHEL works, the TCSC controller was interfaced to RTDS. Studies in RTDS were performed in stages. Initially, a simplified circuit consisting of the Kanpur-Ballabgarh line with both ends represented by Thevenin equivalent source and impedance was considered. The transient response of the controller was studied for step changes in TCSC impedance and line current. In the second phase of the studies, the northern region power system was represented and various contingencies were simulated. The performance of the controller in damping the power swing oscillation in the Kanpur-Ballabgarh line was demonstrated.

The important results of RTDS studies have been compared with the MATLAB digital simulation results. Both the results have a close agreement. The RTDS studies were helpful in carrying out the commissioning tests at site, as the open loop and closed loop tests were conducted very smoothly. The controller when tested on the RTDS had demonstrated a steady state low frequency oscillation when a voltage based damping controller was used or a current based controller with large gain was used. This was confirmed during field trials.

## 2 THE SYSTEM AND ITS REPRESENTATION

### 2.1 The system under study

The TCSC is installed at the Ballabgarh end of the Kanpur-Ballabgarh 400kV line. The range of variable compensation is 8% - 20 % of the line reactance. Figure 1 shows the single line diagram of the TCSC scheme.

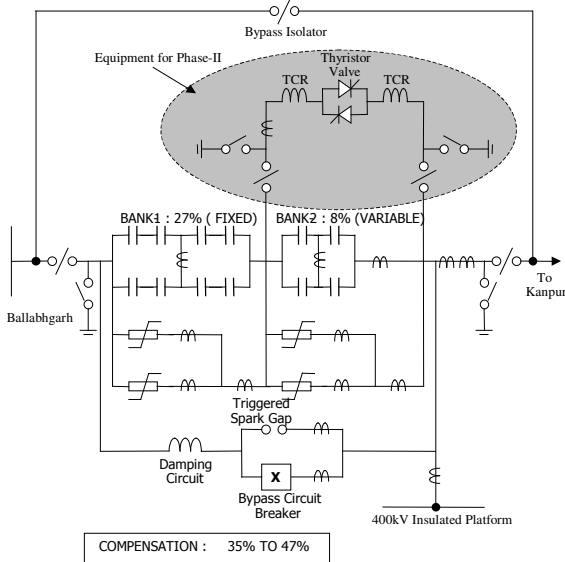

**Figure 1:** Single line diagram of the TCSC scheme.

The major parameters of the system under study are:  
Kanpur-Ballabgarh 400 kV transmission line (400 km):

Positive sequence parameters –

$$L = 1.044\text{mH/km}, C = 16\text{nF/km}, R = 0.0296\Omega/\text{km}$$

Zero sequence parameters –

$$L = 3.259\text{mH/km}, C = 9\text{nF/km}, R = 0.2986\Omega/\text{km}$$

Fixed portion Series Capacitor:  $C = 90.7\mu\text{F}$

TCSC: Fixed capacitor:  $C = 306\mu\text{F}$ ,

$$\text{TCR: } L = 4.4\text{mH}, Q = 50$$

The NREB system comprises of the following elements:

- 87 Generating Stations: 312 generating units with their unit transformers.
- 1003 Lines + Transformers (excluding generator transformers).
- 404 high voltage nodes (132 kV and above) and 312 generator terminal nodes.
- One HVDC bipolar link (Rihand - Dadri) – rated total capacity 1500 MW.
- Two "Back to Back" HVDC links (Vindhyachal and Sasaram).
- One SVC at Kanpur rated at 280 MVAR.
- TCSC (27% fixed 8%-20% variable) on the Kanpur Ballabgarh Line.

As this is a complex network, for RTDS testing purpose a reduced equivalent representation of the system as described in section 2.3 was used.

### 2.2 The system representation for the first phase.

The TCSC was modeled in RTDS with its capacitors, MOVs, spark gap, by pass breaker and TCR. The TCR was modeled with the reactor and the thyristor valve with its snubber circuits and over voltage protection. The fixed series compensation portion was also modeled.

For the first phase of the study, the following parameters were considered to represent the transmission line.

Thevenin resistance / inductance at

Kanpur:  $0.1\Omega, 0.043\text{H}$

Ballabgarh:  $0.1\Omega, 0.026\text{H}$

Quiescent phase angle between the two ends:  $35^\circ$ .

Quiescent voltage magnitudes at both ends: 400 kV line-line rms.

The transmission line, with sources at both ends and voltage and angles adjusted, to achieve the requisite power flow was used. A simplified representation of the transmission line, FSC and TCSC with its RTDS models as shown in figure 2.

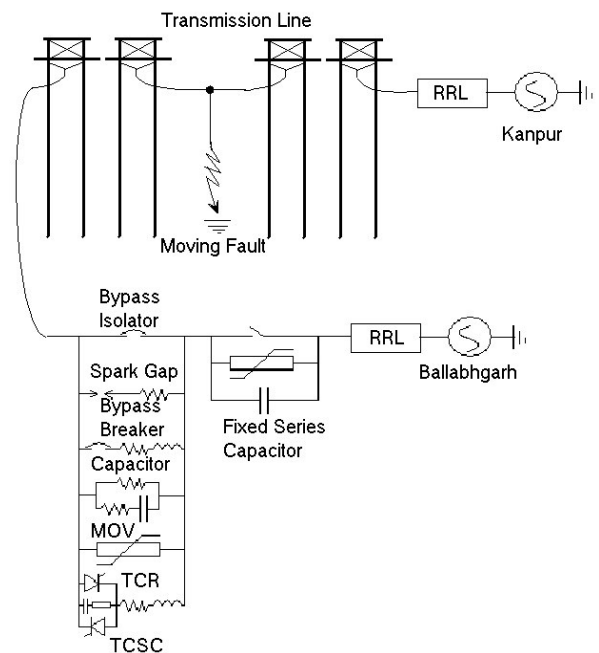

**Figure 2:** Simplified representation of the line, FSC and TCSC RTDS models.

### 2.3 The system representation for the second phase.

As mentioned earlier the size of the NREB system is large and it was not possible to represent the entire system in the RTDS due to its limitations. Hence a reduced equivalent of the system given by the utility as shown in figure 3 was considered for the second phase of the study.

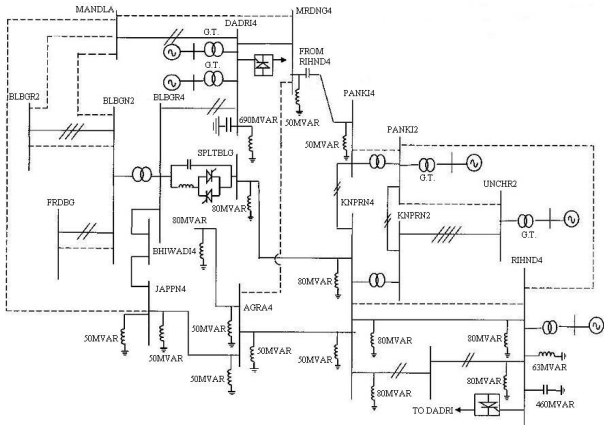

**Figure 3:** Reduced network representation

The reduced network comprised of the following elements:

- 14 infinite sources behind a series impedance.
- 22nos of 400kV lines.
- 11nos of 220kV lines.
- 10nos of fictitious line were modeled as series impedance between buses.
- One HVDC bipolar link (Rihand - Dadri) – rated total capacity 1500 MW.
- One SVC at Kanpur rated at 280 MVAR.
- TCSC (27% fixed 8%-20% variable) on the Kanpur Ballabgarh Line.

### 3 TCSC CONTROL & PROTECTION AND INTERFACE WITH RTDS

#### 3.1 Control Structure

The structure of the controller can be divided into the four levels as follows.

##### 3.1.1 Master Control

This level comprises of the mode selection (current/reactance), open/closed loop selection, voltage and current measurement and interlocking. The required reactance/current level setting is also carried out at this level.

##### 3.1.2 Sub-segment Control

At this level of control depending on the system requirements the Thyristors are blocked, bypassed or put in Vernier Mode. The capacitor overvoltage protection, TCR over current protection, damping control and firing angle control are also carried out.

##### 3.1.3 Base Electronics and Thyristor monitoring

This comprises of the interface of the firing pulses to the thyristor valves and its health monitoring.

##### 3.1.4 Thyristor Control Unit

This level comprises of the electronics to trigger the Thyristor and send feedback to the thyristor monitoring system.

As the controller under test comprised of only the master control and the sub-segment control, the functions of Base Electronics and Thyristor control units were modeled into the RTDS.

#### 3.2 Block Diagram of the TCSC and its control system

Figure 4 gives a block diagram of the TCSC and its controls system.

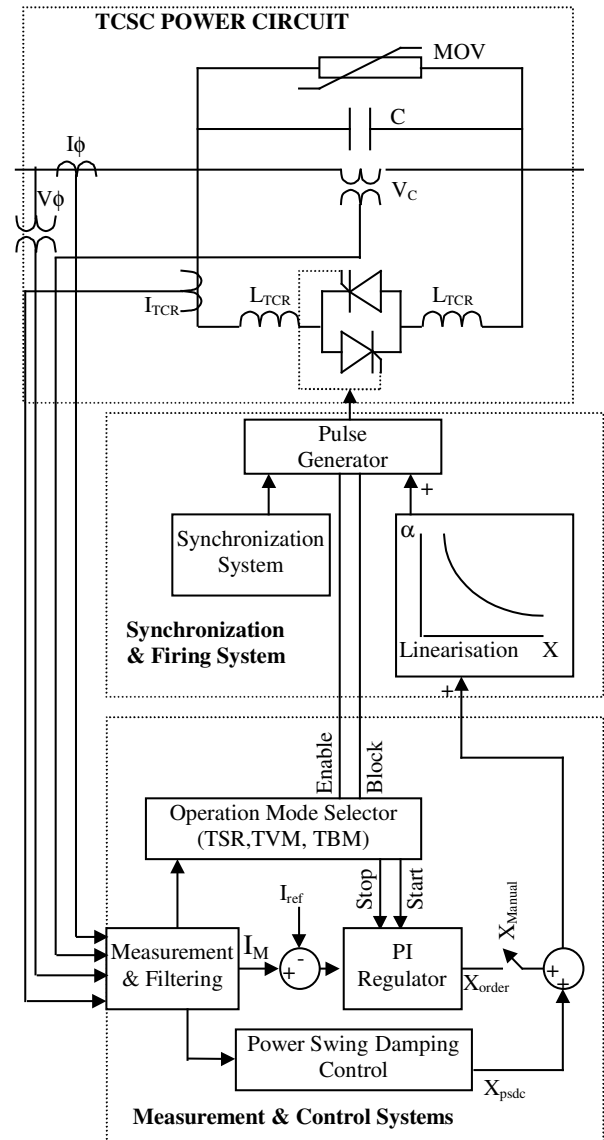

**Figure 4:** Block schematic of the TCSC and its control system.

Abbreviations used in figure 4 which gives a brief outline of the TCSC are:  $I_\phi$  - Line current,  $V_\phi$  - Line voltage, MOV- Metal Oxide Varistor, C- Capacitor,  $V_C$  - Capacitor Voltage,  $L_{TCR}$  - Thyristor Controlled Reactor,  $I_{TCR}$  - Thyristor Controlled Reactor Current,  $\alpha$  - Firing angle, X - impedance, TSR -Thyristor Switched Reactor, TVM - Thyristors in Vernier Mode, TBM - Thyristors in Blocked Mode,  $I_M$  - Measured line current,  $I_{ref}$  - Reference line current, PI - Proportional Integral,  $X_{order}$  - Ordered impedance,  $X_{Manual}$  - Open

loop impedance setting,  $X_{psdc}$  – Impedance modulated by the damping controller.

### 3.3 Interfaces to the RTDS

The line voltage and line current inputs from the RTDS were scaled down and given as voltage signals to the controller. The analog signals, TCR current, Capacitor voltage and fault to platform current were fed as scaled voltage signals to the controller. The digital inputs were given as opto-isolated inputs to the controller.

The firing pulses from the controller were given as digital inputs at 5V level to the RTDS. The other signals like “Block” and “Bypass” were given through opto-isolated inputs to the RTDS.

### 3.4 Control and Protection features

The following are the main features provided in the controller.

#### 3.4.1 Reactance scheduler

The reactance scheduling can be done by the operator depending on the network requirements. The default value is  $12.5\Omega$  working at a boost factor of 1.2, though the operator can choose a value in the range of  $10.4\Omega$  to  $25\Omega$  i.e. a boost factor of 1 to 2.5. The reactance scheduler is a slow controller that adjusts the firing angle to achieve the set reactance level in steady state. This controller is overridden by other faster controllers like the damping controller and voltage and current limiters.

#### 3.4.2 Current (Power) scheduler

The reactance-scheduling mode is the default mode of operation but an operator can select a current or power scheduler mode depending on the system requirements. The current or power scheduler mode is similar to the reactance scheduler. It will be active only if the reactance controller is disabled and the current control activated. The controller permits a current setting in the range of 150A to 1200A. The controller will change the firing angle to achieve this within its range. In case of overload the limiters will come into action.

#### 3.4.3 Power swing oscillation damping control

The power swing oscillation-damping controller is a fast controller that modulates the output of the scheduler to damp out the power swing oscillations detected. The damping controller was tested for two cases of input signals (i) line current and (ii) line voltage. The line current based damping controller calculates the drop in voltage across the transmission line using the line current as an input whereas the line voltage based damping controller uses the measured line voltage directly.

#### 3.4.4 SSR mitigation

Studies have revealed [2] that the TCSC working in the constant impedance mode with nominal firing angle is inductive in the SSR frequency range. Hence, no additional SSR mitigation controller was envisaged.

#### 3.4.5 Capacitor overvoltage control

The TCSC can be operated at maximum boost continuously only for a line current of about 600A, but for higher line currents it can operate at maximum boost only for a short duration. The short time voltage rating of the capacitor is taken into consideration and time dependent voltage limiter is incorporated to reduce the boost automatically.

#### 3.4.6 TCR over-current control

Similar to the capacitor's voltage rating, the TCR also has a short time current rating. A time dependent over current limiter is incorporated to reduce the boost automatically.

#### 3.4.7 TSR mode on internal line faults

The controller detects the internal line faults from the amplitude of the line current and sets the TCSC into the TSR mode.

#### 3.4.8 Open loop control

The open loop controller is provided only for checking the controller in the manual mode during testing and trials.

#### 3.4.9 Thyristor Monitoring system

The thyristor valve comprises of a number of thyristors in series. The thyristor monitoring system continuously monitors all the thyristor levels of the valves. Alarms and trip is generated based on the number of failures exceeding the pre-defined number of thyristor levels.

#### 3.4.10 Valve cooling control

De-ionized water is circulated in the thyristor valve to cool the thyristors and the snubber resistors. The controller controls the pumps and heat exchangers of the cooling system. It also monitors the water temperature, flow and conductivity of the cooling system. Depending on the healthiness of the various cooling system parameters, change over of pumps or requisite alarms and trips are initiated.

#### 3.4.11 Self Diagnostics

The controller has self-diagnostic features built-in. It continuously monitors its own healthiness and a trip is generated in the event of its hardware failure.

## 4 TESTING AND RESULTS

### 4.1 First phase of testing

The first phase of testing was carried out using the simplified network described earlier. The following studies were carried out with this simplified network.

#### 4.1.1 Open loop or manual mode checking.

The open loop or manual mode was tested to ensure proper synchronization and interfacing to the RTDS. The firing angle was manually increased and decreased to result in the desired increase and decrease in boost.

#### 4.1.2 Impedance control mode.

In the impedance control mode, step changes were given to increase and decrease the boost. The set impedance level was changed from  $12.5\Omega$  to  $26\Omega$  and back from  $26\Omega$  to  $12.5\Omega$ , as shown in figures 5 and 6 respectively.

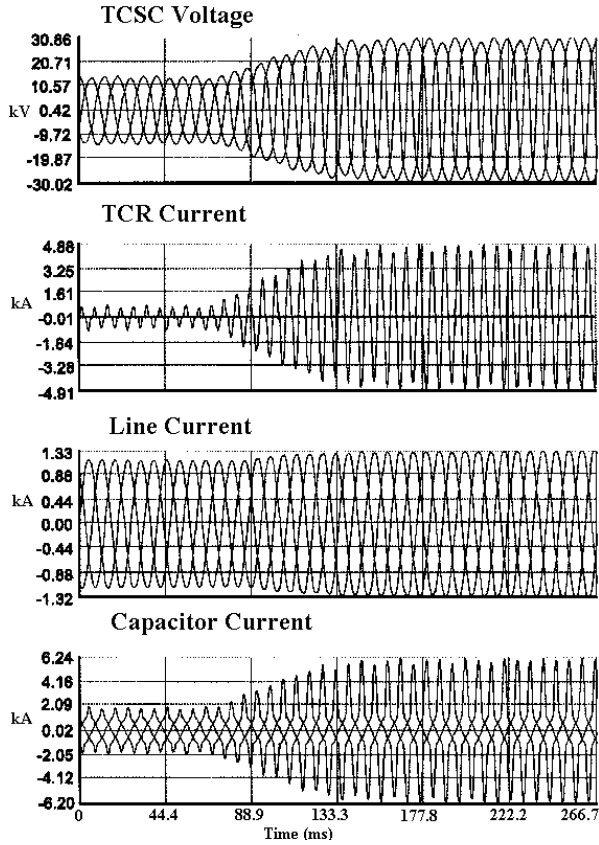

Figure 5: Step increase in the impedance setting.

Though the reactance scheduler is a slow controller the response times were decreased to demonstrate that a fast change was also smooth and did not cause any system disturbance.

#### 4.1.3 Current control mode.

In the current control mode, step changes from 700A to 800A and back from 800A to 700A, as shown in figures 7 and 8 respectively, were given to increase and decrease the boost. As the current scheduler is a slow controller the response times were kept at around 3 seconds, the response was smooth and did not cause any system disturbance. As response time is large, the figures 7 and 8 show only an envelope of the waveforms.

#### 4.1.4 Frequency compensation.

The frequency compensation provided in the controller was tested by gradually changing the system frequency from 47Hz to 53Hz. The controller did not demonstrate any abnormality and found to be working satisfactorily.

#### 4.1.5 Capacitor over voltage and TCR overcurrent protection.

For continuous operation, the entire impedance range of  $12.5\Omega$  to  $26\Omega$  of the TCSC can be used only for a line current of less than 600A. But for a line current of greater than 600A will result in an over voltage across the capacitor at higher impedance values. Hence an automatic time dependant voltage-limiting feature is provided in the controller. This feature was checked by increasing the line current and creating an overvoltage across the capacitor. It was demonstrated that firing angle was automatically varied to reduce the over voltage.

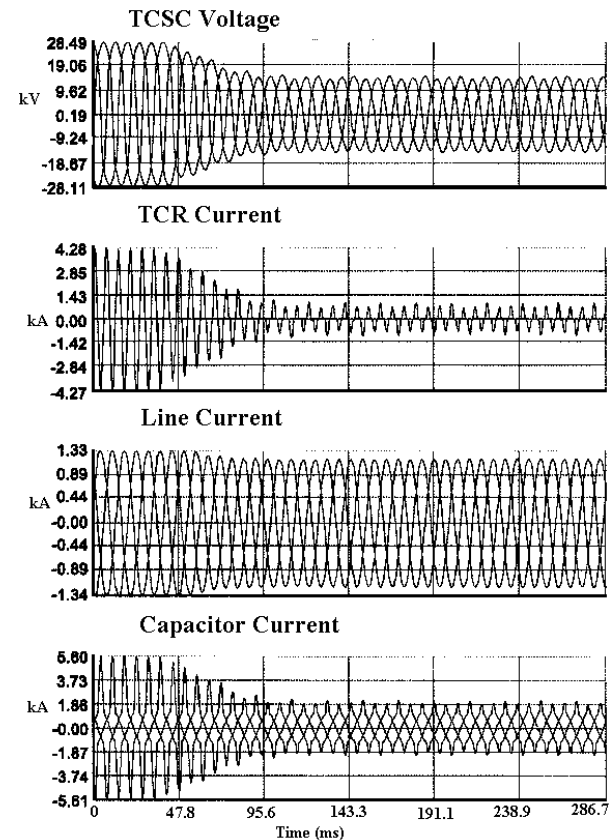

Figure 6: Step decrease in the impedance setting.

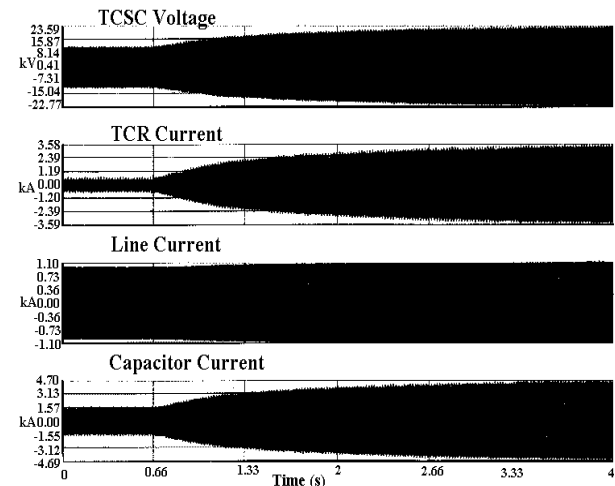
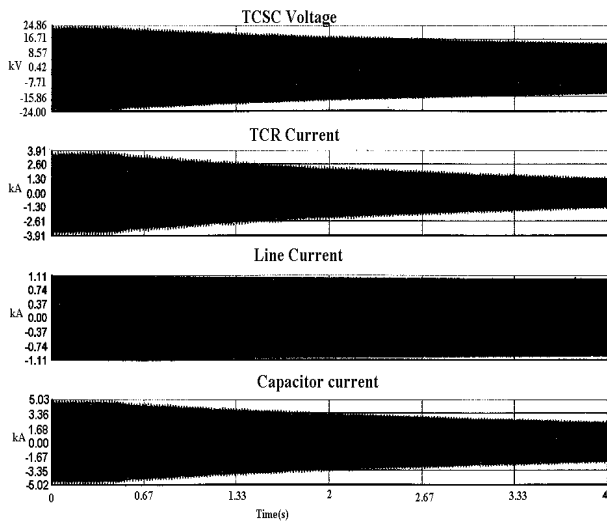

Figure 7: Step increase in the current setting.



**Figure 8:** Step decrease in the current setting

Similarly, operation at line currents greater than 600A and higher values of TCSC impedance also results in an over current in the TCR. This over current needs to be limited depending on the capability of the TCR. An over current was created in the thyristor-controlled reactor by increasing the line current and the time dependant current limiting feature was checked.

At the installation, the TCSC voltage and the TCR current signals to the controller are obtained by means of an Optically Powered Data Link (OPDL) with a voltage divider and a CT kept on the 400KV platform.

#### 4.1.6 Internal line faults.

Fault on the Kanpur – Ballabgarh transmission line are considered as internal line faults. In case of any fault on this line, the Thyristor switched reactor (TSR) mode should be activated. It was demonstrated that for internal line faults the TSR mode was successfully enabled helping in reducing the stress on the MOV as shown in figure 9.

#### 4.2 The second phase of testing

The second phase of testing was carried out using the reduced network described earlier. The studies carried out in the first phase were repeated to verify the performance. The following system disturbances were carried out with this reduced network.

##### 4.2.1 External Line faults.

An external line fault refers to any fault on any transmission line other than the Kanpur – Ballabgarh transmission line. In case of external faults, the Thyristor switched reactor (TSR) mode should not be activated. This feature was successfully tested by simulating faults like outage of the HVDC line and outage of the neighbouring lines like the Panki-Muradnagar line.

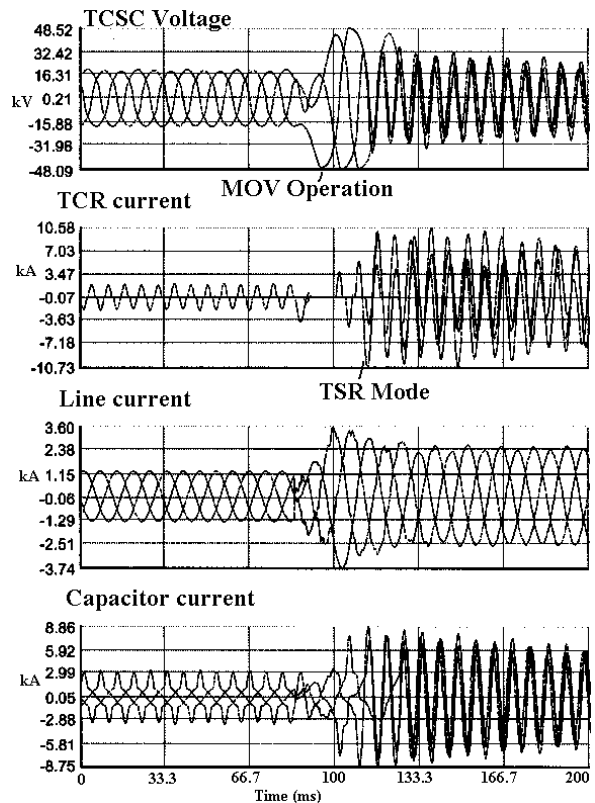

**Figure 9:** Three phase to ground fault on the Kanpur – Ballabgarh transmission line.

##### 4.2.2 Power swing oscillations.

An outage of any major parallel transmission line or an outage of the HVDC line results in a power swing. The effectiveness of the damping function was checked. In the MATLAB studies [3], [4] conducted primarily, two signals were considered, (i) the line current, from which the voltage drop in the line was calculated, and (ii) the line voltage, for the damping controller, as shown in figures 10 and 11 respectively.

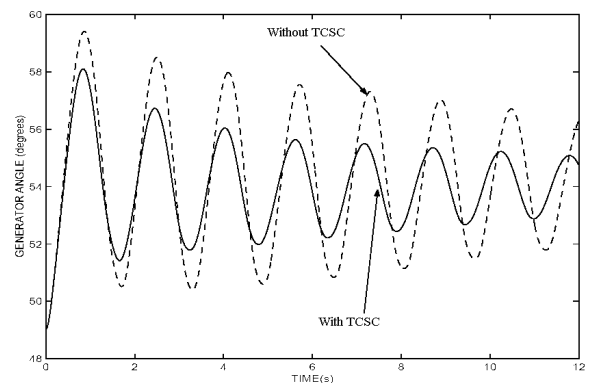

**Figure 10:** Damping on outage of HVDC line with the current based controller on MATLAB.

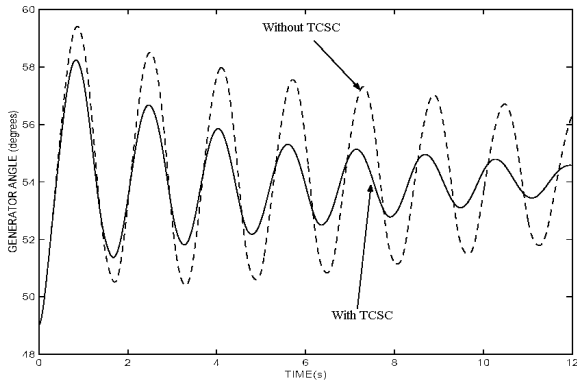
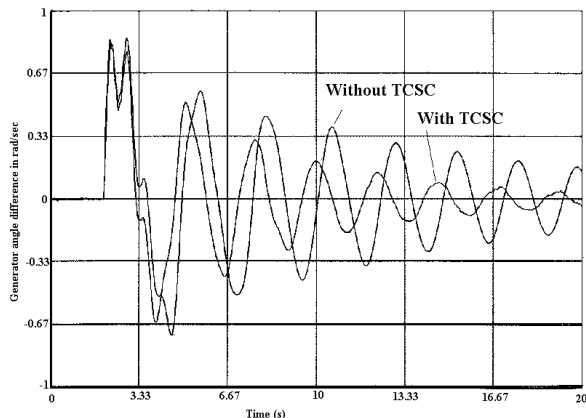

**Figure 11:** Damping on outage of HVDC line the voltage based controller on MATLAB.

The MATLAB studies had shown that the voltage based damping controller provided better damping but it introduced a low frequency oscillation on steady state.

It was confirmed during RTDS testing that though the voltage based damping controller yielded better damping, it also created a disturbance in the steady state as shown in figure 12. This result concurred with the MATLAB simulation results.

The current based damping controller provided satisfactory damping without disturbances in steady state. This is clear from figure 13. However, in this case also, a disturbance in the form of a low frequency oscillation was noticed under steady state with larger values of gain.



**Figure 12:** Damping on outage of HVDC line with the voltage based controller on RTDS.

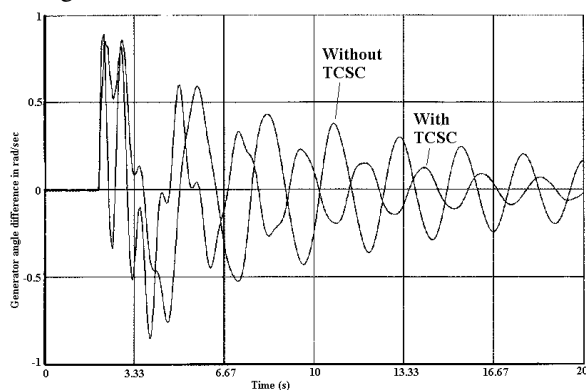

**Figure 13:** Damping on outage of HVDC line with the current based controller on RTDS.

### 4.3 Conclusions

The TCSC controller was tested for its performance under normal system conditions as well as during system disturbances. Impedance control mode, current control mode, changing operating modes, open loop, closed loop operation and frequency compensation were checked, and the response found satisfactory. The capacitor over voltage and TCR over current protection features were successfully tested. Internal and external line faults were created and the controller behaved as desired. The damping controller with voltage and current based damping were studied and the results were in close concurrence with MATLAB simulation results.

Steady state commissioning tests of the TCSC have been carried out in the field. The controller's steady performance at site is in concurrence with the RTDS studies. It was also noticed at site that the increase in gain of the line current based damping controller affects the controller's steady state performance in the form of a low frequency oscillation.

## 5 ACKNOWLEDGEMENTS

The authors are thankful to the management of M/s Bharat Heavy Electricals Limited (BHEL) for their kind permission in publishing this paper and the support rendered. The authors would also like to thank Mr. Manoj Kumar (BHEL-IS) and Dr. Kulkarni (IIT, Mumbai) for their contributions.

## 6 REFERENCES

- [1] IEEE Std 1534-2002 IEEE Recommended Practice for Specifying Thyristor-Controlled Series Capacitors.
- [2] Luiz A. S. Pilotto, Andre Bianco, Willis F. Long and Abdel-Aty Edris "Impact of TCSC control methodologies on subsynchronous oscillations", IEEE transactions on Power Delivery vol 18, pp 243-252, January 2003.
- [3] A.M. Kulkarni, "A study of critical swing modes of NREB and Damping controller design of the Kanpur – Ballabgarh TCSC", March 2002.
- [4] A.M. Kulkarni, "Design and Simulation of lower level controllers for Kanpur-Ballabgarh TCSC", March 2003.