

ADVANCED PROBABILISTIC POWER FLOW METHODOLOGY

George Stefopoulos, A. P. Meliopoulos and George J. Cokkinides
School of Electrical and Computer Engineering
Georgia Institute of Technology
Atlanta, Georgia 30332-0250, USA

Abstract – A comprehensive model for stochastic load flow analysis in electric power systems is proposed for the purpose of estimating the statistics of bus voltage magnitudes, circuit currents and transmission line power flows. The proposed method is driven by a realistic non-conforming stochastic electric load model, defined in terms of few independent stochastic processes; it is based on the quadratized power flow formulation and it can account for the major operating practices of electric power grids, such as economic dispatch, congestion management or other network constraints. The statistics of circuit currents, bus voltage magnitudes, and line power flows are computed from linearized models of these quantities with respect to the independent stochastic load variables at multiple points. The method is validated via Monte Carlo simulations in which the problem is fully solved for each random sample, incorporating nonlinearities resulting from the AC power flow equations and operating constraints. The proposed method is demonstrated with the IEEE Reliability Test System (RTS) and results are presented in the paper.

Keywords: Monte-Carlo simulation, Multi-point linearization, Probabilistic power flow, Sensitivity analysis, Stochastic load flow

1 INTRODUCTION

Load flow analysis is the most widely used tool for steady-state studies in power systems. Its application is based on the assumption that the system loading is precisely known. That is, the electric load and generation are deterministically known quantities. However, in many cases the load needs to be assumed stochastic in nature and therefore the power system operation has to be studied based on estimates of this demand and taking into consideration the probabilistic nature of the load. This is performed using the stochastic load flow analysis, also referred to as probabilistic power flow analysis. Probabilistic power flow is a term that refers to power flow analysis methods that directly treat the uncertainty of electric load and generation.

The first notions of probabilistic power flow analysis appeared in the early 1970s [1]–[3]. In [2] and [3] a simplified probabilistic load flow is proposed, based on the assumptions that the active bus loads are independent random variables and the transmission system is represented by the DC network model (thus the reactive power flow is neglected). The generation dispatch procedure is modeled with an arbitrary function which allocates the variation of the total electric load to specific generation buses. Since the variables of the active electric load at each bus are assumed independent, the probability density

function of the circuit flows can be computed with a series of convolutions. Later, this basic method was extended and it was also applied to the AC network model [4,5]. A conventional deterministic power flow analysis is performed initially, assuming net bus loads equal to their mean values. This solution determines the operating point about which the load flow equations are subsequently linearized.

The assumption of independence of the nodal electric loads is, however, quite unrealistic. In [6] a linear dependence between nodal powers in probabilistic load flow is suggested. This assumption is also implied by Allan *et al.* in [7]. In [8], a linear dependence model of electric loads is proposed, again, along with a method which combines Monte Carlo simulation and convolutions, using a linearized power flow model. In [9], Dopazo *et al.* used a method which models the correlation between the loads at any two buses. Their proposed method assumes that circuit flows and bus voltage magnitudes are Gaussian distributed and, thus, only their variance should be computed. However, Monte Carlo simulations indicate that it is unrealistic to assume, a priori, Gaussian distributions of circuit flows and bus voltages [7,8,10]. For this reason, Sauer and Heydt [11] have proposed the use of higher moments (third and fourth) for accurate representation of the probability distribution functions. The topic of probabilistic power flow was further investigated in the mid and late 80's. Some typical extensions and improvements can be found in [12-15]. An extended literature review on power system probabilistic analysis (until the late 80's) can be found in [16].

An efficient method for treating the correlation among bus loads and the generation dispatch procedure is proposed in [17]. The model assumes Gaussian distribution of bus loads and a linearized economic dispatch model. The circuit flows and bus voltages are expressed as a linear combination of the bus loads only, and are assumed to be normally distributed. The linearized equations are utilized to determine the moments of probability density function of circuit flows and bus voltages. The inclusion of this model in a reliability analysis method resulted in more accurate representation of the electric load at reduced computational requirements [17]. While this approach models the economic redispatch of generating units due to electric load variations, it is based on the linearized power flow equations and the linearized economic dispatch model. In [18] the method was further extended addressing the issues of the economic dispatch of the generating units, the effects of nonlinearities of the power system model and the uncertainty associated with

the availability of the generating units. In [19] the basic ideas from [17] and [18] were extended to the problem of transmission loss evaluation. Furthermore the a priori assumption that the circuit loadings and bus voltages are normally distributed was waived.

This work extends some of the ideas presented in [17], [18] and [19]. More specifically this paper applies a stochastic load flow methodology to the quadratized power flow model [20-22]. In addition it introduces a non-conforming stochastic electric load representation. Details on the quadratic power flow formulation can be found in [20-22]. This paper focuses on the non-conforming load model which represents the electric load accurately and realistically with a few independent stochastic processes, $[v]$. The parameters of these processes are determined from historical bus-load data. The proposed methodology computes statistics of quantities under study from their linearized models with respect to the independent load variables $[v]$, around the expected value of the non-conforming load. Emphasis is given in the ability of taking into consideration major operating practices such as economic dispatch and possibly congestion management or observation of network constraints. The intended application of the proposed methodology is operations planning. However, it is our belief that it can be easily extended to long term planning or on-line operation.

2 PROBLEM STATEMENT

Consider an electric power system consisting of the power grid, the loads, and the generating units. Given the probabilistic load model, it is desired to calculate the statistics of the voltage magnitude at each bus and of the current magnitude and power flow at each system branch considering the operating constraints and optimization practices of the system.

More specifically it is desired to compute the statistics of the current magnitude I_{km} (or the apparent power flow T_{km}) of any circuit connecting buses k and m , or the voltage magnitude at any bus k , V_k . The operation of the system is constraint by circuit capacities, voltage magnitude regulation and the need to optimize the operation of the system (minimize operating cost, economic dispatch). We view circuit flows and voltage magnitudes as functionals of the parameters affecting the operation and which account for major operating practices such as economic dispatch and congestion management.

3 PROPOSED MODEL DESCRIPTION

3.1 Non-conforming electric load stochastic model

The electric load representation is a key issue in a probabilistic load flow methodology. Total independence of bus loads has been extensively assumed in literature [2,3,5,7,9,10]. This assumption, in combination with linearized power flow equations results in the solution of the probabilistic load flow being a sum of independent random variables weighted by sensitivity coefficients.

Therefore, it can be obtained by a series of convolutions. However, this assumption of independence is quite unrealistic [4,6,8,18,19], since there are various reasons for correlation to exist between bus loads [8].

A typical probabilistic load model is a conforming electric load model, i.e. a specific bus load is a fixed percentage of the total system load. Statistically, this means that the bus loads are correlated one hundred percent. This practice fails to represent the fact that the actual loads are not fully correlated. For a more realistic representation of the electric load, it is necessary to represent the bus electric load as a non-conforming load. We propose a generalized nonconforming electric load model which is defined in terms of n independent and zero mean random processes (typically no more than three to five). At a certain instance of time (or certain time interval) the stochastic processes become random variables with specific probability distribution functions and of zero mean. The characterization of the random variables and thus the determination of the non-conforming load model can be obtained from bus historical data using load forecasting methods, which are, however, outside the scope of this paper. Here we assume that the model of the independent stochastic processes is given. If the number of bus loads in the system is L the entire system active and reactive loading can be represented as two L -dimensional vectors:

$$\vec{P}_d = \vec{P}_d^0 + \vec{v} \cdot \vec{P}_d, \quad (1)$$

$$\vec{Q}_d = A \cdot \vec{P}_d, \quad (2)$$

where

\vec{P}_d : L -dimensional active load vector, $\vec{P}_d = [P_{dk}]$,

\vec{P}_d^0 : L -dimensional base case load vector, $\vec{P}_d^0 = [P_{dk}^0]$,

\vec{v} : n -dimensional vector of stochastic load variables,

\vec{P}_d : nxL matrix of participation coefficients,

$$\vec{P}_d = [p_{dk}^i], \quad i=1, \dots, n \text{ and } k=1, \dots, L,$$

\vec{Q}_d : L -dimensional reactive load vector,

A : $L \times L$ diagonal matrix of proportionality constants

$$A = \text{diag}(a_k) \quad k=1, \dots, L.$$

It is assumed that the load at each bus k maintains a constant power factor; therefore the reactive power consumption at bus k is proportional to the active power consumption, with a constant of proportionality a_k . This assumption may be rather limitative, however, it is a commonly made assumption in many cases (including actual utility practices and studies) and provides a good starting point. It will be waived in future work by slightly complicating the load model. Specifically, the parameters a_k will be replaced with stochastic processes, which will enable realistic representation of power factor variations.

The presented non-conforming load model assumes variable correlation between the various bus loads. Note that in a conventional conforming load model the bus loads are fully correlated. If $v_i = 0$ for $i=2, \dots, n$ then the

non-conforming load model becomes a simple conforming load. The load variations at every bus have the exact same statistics, imposed by the single random variable v_1 . If $n \geq 2$ then the above model becomes a non-conforming load model. The ability of this model to represent the variable correlation between bus loads is illustrated with the very simple system in Figure 1.

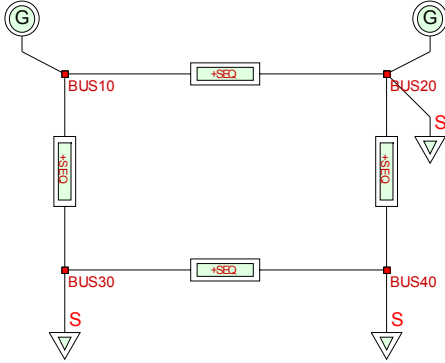

Figure 1. System for illustration of the correlation among bus loads when using non-conforming load representation

We assume that the bus loads are given by:

$$\begin{aligned} P_1 &= 100 + 4v_1 + v_2, \\ P_2 &= 50 + 2v_1 + 5v_2, \\ P_3 &= 200 + 8v_1, \end{aligned} \quad (3)$$

where $v_1 \sim N(0,1)$ and $v_2 \sim N(0,2)$.

Computation of the correlation of the bus-loads gives:

$$\begin{aligned} \text{Cor}[P_2, P_3] &= 0.577 \\ \text{Cor}[P_2, P_4] &= 0.943 \\ \text{Cor}[P_3, P_4] &= 0.272 \end{aligned} \quad (4)$$

which indicates that there is variable correlation among the loads. Note that if a conforming load model of one random variable was used then every bus load would be 100% correlated with each other.

3.2 Generation model

The probabilistic nature of the load imposes variations to the total generation required by the system. This is mainly due to the variation of the power demand, and to a lesser degree on changes of transmission losses as the power demand changes.

The total change in generation that is to be dispatched among the units is set equal to

$$\Delta P_g = \gamma \cdot \sum_{k=1}^L \sum_{i=1}^n p_{dk}^i \cdot v_i, \quad (5)$$

where the involved quantities are

- ΔP_g : total generation change,
- γ : coefficient accounting for the change in system losses (computed at the base case),
- v_i : i^{th} random variable from the set of n independent zero mean load random variables,
- p_{dk}^i : participation coefficient for the i^{th} random variable v_i (provided by the load model),

L : total number of constant power loads in the system.

Here coefficient γ expresses the change in losses as a percentage of the change in the load demand. It is a coefficient computed at the base-case operating point.

In order to distinguish between the cases of load increase and load decrease (i.e., $\Delta P_g > 0$ or $\Delta P_g < 0$) two additional random variables, w^+ and w^- , are introduced,

representing the total load increase and total load decrease, respectively. The distinction between load increase and decrease is necessary since we will assume a linearized unit dispatch and the participation factors for increase and decrease in load are in general different for each unit, especially if a unit is operating close to one of its limits. Similarly, two coefficients for the losses, γ^+ and γ^- are defined. Therefore, equation (5) can be rewritten as

$$\frac{w^+}{\gamma^+} - \frac{w^-}{\gamma^-} = \sum_{k=1}^L \sum_{i=1}^n p_{dk}^i \cdot v_i, \quad (6)$$

with the additional constraints:

$$w^+, w^- \geq 0, \quad (7)$$

$$w^+ \cdot w^- = 0. \quad (8)$$

Equation (8) imposes that only one of w^+ or w^- is non-zero and both cannot be nonzero at the same time. Equation (6) provides a linear relation between the independent random variables, v_i 's, and the dependent variables w^+ and w^- .

The re-dispatch is performed linearly among the units based on the values of the participation factor of each generator, at the base case operating point. Each unit k is assigned one participation factor for load increase and one for load decrease, denoted as p_{gk}^+ and p_{gk}^- respectively. In general these two have different values, especially close to the upper or lower limit respectively. If a unit is operating at its upper or lower limit then the corresponding participation factor is zero while the other one is non-zero. Thus the active power generation of each unit k is

$$P_{gk} = P_{gk}^0 + p_{gk}^+ w^+ - p_{gk}^- w^-, \quad (9)$$

where the symbols are defined as

P_{gk} : new active power production of unit k ,

P_{gk}^0 : base case active power production of unit k ,

p_{gk}^+ : participation factor of unit k for total demand increase,

p_{gk}^- : participation factor of unit k for total demand decrease,

w^+ : dependent random variable of total demand increase,

w^- : dependent random variable of total demand decrease.

The values of the participation factors are calculated by the economic dispatch algorithm. However, in this paper they are assigned based on how close to its upper or lower limit respectively each unit is operating. Therefore the participation factors are proportional to the difference between the actual production at base case and the unit limits.

For the generated reactive power of units operating in PQ mode, we assume that the power factor is constant, therefore the change in their reactive production is proportional to the change in the active power production, so that the power factor is kept constant.

3.3 Transmission network model

The network quantities (circuit currents, power flows or bus voltages) are also treated as random variables that depend on the stochastic load variables, v_i 's. Linear dependence is assumed for small deviations around an operating point, and therefore circuit currents, flows and bus voltages are linearized with respect to the load variables, v_i . Specifically, a network quantity F (i.e. line current, power flow or bus voltage) is expressed as a linear combination of the load random variables as:

$$F = F^0 + \sum_{i=1}^n (c_i \Delta v_i), \quad (10)$$

where

F^0 : Base case value of F ,

c_i : Linearization coefficient of quantity F with respect to v_i .

Since v_i 's are independent random variables the statistics of the quantity F are derived from the statistics of the v_i variables by simply performing a series of convolutions on the probability density functions of v_i 's.

The proposed method is based on the concept of utilizing a linearized model around a specific value of electric load as defined by a sample of the electric load model variables. The linearized model is constrained with the operational practices such as economic dispatch, congestion management and others. The performance of the system in terms of distributions of bus voltage magnitudes, circuit currents and flows is derived from the linearized model. To further improve on the accuracy of the proposed method the non-conforming load model is sectionalized into a small number of segments as it is depicted in Figure 2. A specific combination of a segment from each variable defines an electric load event. Such an event C_i is illustrated in Figure 2. We then consider the conditional probability of the electric load given that the electric load belongs to the electric load event C_i . Subsequently, we consider the conditional expected value of the electric load given that the load belongs to event C_i . The operating conditions of the system at the conditional expected value are determined by simulation of the elec-

tric power network. Then the linearized model of the system is computed around this operating point. Finally, the conditional (given event C_i) performance of the system in terms of distributions of bus voltage magnitudes, circuit flows and total operating cost are derived from the linearized model and the known conditional electric load model. The procedure is applied to all possible electric load events and the results are weighted with the probabilities of the electric load events and summarized into an overall probabilistic model. It is important to note that at each expected value of a load event congestion management or any other type of remedial actions can be applied, if necessary, as well as the effect of possible contingencies can be accounted for.

The basis of this idea is depicted in Figure 2. Three stochastic load variables are assumed, namely v_1 , v_2 and v_3 following some probability distribution in the interval $[a, b]$. This interval is divided into three sections, and the expected value of each load random variable is calculated in each section. The triplet of such expected values of each load variables defines a specific load profile and therefore a base case operating point. Furthermore, a triplet of such sections, one for each variable, defines a possible event, i.e. event \mathcal{E} of Figure 2 is defined as:

$$C_i = \{v_1 \in (d_{12}, b_1) \cap v_2 \in (d_{21}, d_{22}) \cap v_3 \in (d_{31}, d_{32})\} \quad (11)$$

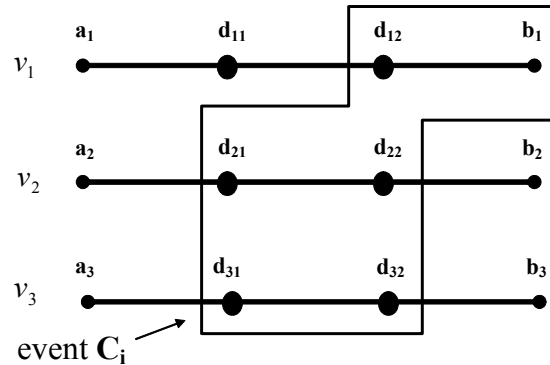

Figure 2. Schematic representation of non-conforming load sectionalization

For each electric load event, the base case conditions of the electric power network are computed as well as the linearized model around the base case conditions. Assuming n random processes and m sections for each process the total number of events to be considered is m^n . Although the number of events can be very large, leading to bulky computations, in practice we anticipate that no more than three to five random processes will be needed and three to five sections for each variable can provide adequate results. This results in several hundreds or maybe a few thousand events, and therefore load flow computations. This is still typically one or two orders of magnitude better than Monte Carlo simulation, where several tenths or even hundreds of thousands of trials might be necessary in a typical situation to get credible results. It should be clarified, however, that since linearization are involved there is always some approximation involved in the results, which is greater as the degree of

nonlinearity increases. Multi-linearization mitigates this effect, but cannot eliminate it.

4 MONTE CARLO SIMULATION

The proposed multiple-point-linearization based methodology is validated with an independent method based on Monte Carlo simulation. Specifically, the same problem is also solved via Monte Carlo simulation in which each random sample is fully solved, thus incorporating nonlinearities resulting from the AC power flow equations and major operating practices such as economic dispatch and congestion management or other necessary remedial actions. Both the linearization solution and the Monte Carlo approach are based on the Single Phase Quadratic Power Flow model.

The basic idea of Monte Carlo simulation is to simulate a specified system with a reasonable number of random draws of all possible system states according to their probability distributions. In this model, the circuit currents, line power flows and bus voltages are computed for a system state determined from a random draw of the state of electric load, that is, by a random draw of the values of the stochastic load variables. Economic dispatch and congestion management, or other possible remedial actions take place at any state that it is necessary, in order to bring the system to an acceptable and secure operational condition. In the Monte Carlo simulation a large number of random draws are generated. The process generates the statistics of circuit currents and the bus voltages. Specifically the cumulative probability distribution function of these quantities is generated. From this distribution, other quantities, such as the probability density function, the expected value, the variance, the standard deviation, etc. can be computed.

5 PRELIMINARY RESULTS

The proposed method has been applied to the IEEE 24-Bus Reliability Test System (RTS-24), illustrated in Figure 3. The system is operating at peak loading, at base case. The detailed system data for each system component can be found in [23]. The nonconforming load model consists of two zero mean stochastic load variables namely v_1 and v_2 , which are assumed to be normally distributed with zero mean and variance of 0.1. Therefore, each bus load is expressed as a linear function of these two random variables, i.e.,

$$P_{dk} = P_{dk}^0 + p_{dk}^1 \cdot v_1 + p_{dk}^2 \cdot v_2, \quad (12)$$

where

P_{dk} : active power demand (load) at bus k ,

P_{dk}^0 : base case load value at bus k ,

p_{dk}^1 : participation coefficient for the 1st random variable,

p_{dk}^2 : participation coefficient for the 2nd random variable.

Three cases are considered for the proposed multi-linearization approach. The stochastic load variables are

segmented into one, three and five sections. Comparative results from all the cases are presented. For validation purposes and for the small IEEE RTS-24 20000 Monte Carlo trials are used. Since Monte Carlo simulation is used only for validation purposes, at this stage, no attempt was made to formally estimate the required number of trials, for a particular confidence level.

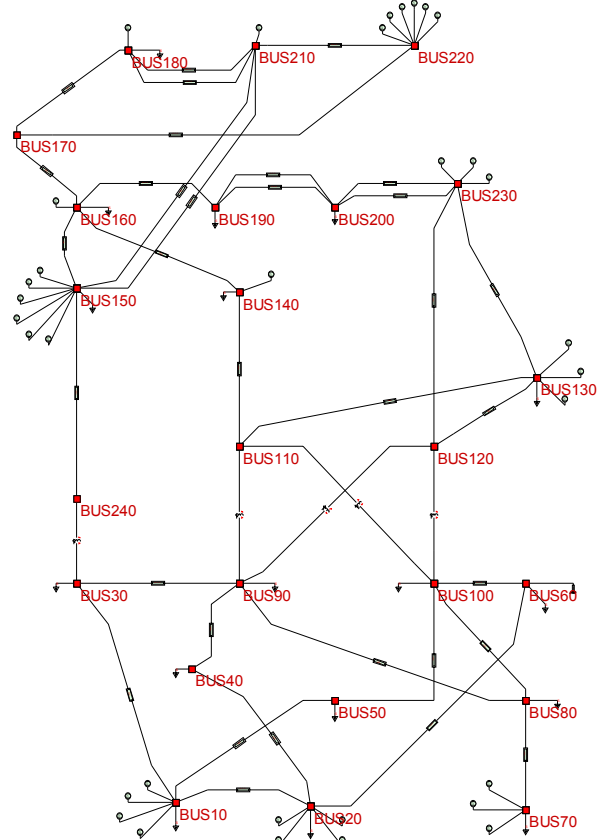

Figure 3. The IEEE 24 Bus Reliability Test System

Tables 1 and 2 provide a comparison between the mean value, standard deviation and third and fourth moments for several network quantities, as calculated using the proposed approach and using the Monte Carlo (MC) simulation results. A close agreement between the results is observed for the voltage magnitudes of the PQ system buses, even when using single point linearization. A very close agreement, even when using single linearization, is also observed for the majority of the circuit currents, as shown in Table 2. Figure 4 shows the probability density and distribution function for the current magnitude at circuit 200-230 as obtained using the proposed multi-point-linearization method and Monte Carlo simulation.

In only few of the circuits was there a significant mismatch between the proposed method with single linearization and the MC simulation results. This mismatch is minimized or even eliminated when multi-linearizations are used. Results from these circuits are shown in Table 3 and probability distribution plots of such a case are presented in Figure 5.

Bus		Proposed Method			MC
		1 Lin.	3 Lin.	5 Lin.	
90	Mean (kV)	131.96	131.91	131.90	131.86
	Std. Dev. (kV)	0.71	0.73	0.73	0.73
	Skewness	0.02	-0.54	-0.59	-0.65
	Kurtosis	2.99	3.52	3.58	3.79
100	Mean (kV)	133.04	132.99	132.98	132.93
	Std. Dev. (kV)	0.81	0.83	0.83	0.83
	Skewness	0.02	-0.50	-0.55	-0.59
	Kurtosis	3.00	3.45	3.50	3.67
110	Mean (kV)	223.77	223.70	223.68	223.62
	Std. Dev. (kV)	1.09	1.12	1.11	1.11
	Skewness	0.03	-0.57	-0.63	-0.68
	Kurtosis	3.00	3.57	3.63	3.84
120	Mean (kV)	224.79	224.73	224.71	224.65
	Std. Dev. (kV)	1.15	1.17	1.17	1.17
	Skewness	0.03	-0.49	-0.54	-0.59
	Kurtosis	3.00	3.43	3.48	3.64

Table 1: Comparison of proposed linearization method and Monte-Carlo simulation results for PQ bus voltage magnitudes

Circuit		Proposed Method			MC
		1 Lin.	3 Lin.	5 Lin.	
210-220	Mean (A)	332.51	332.52	332.52	332.51
	Std. Dev. (A)	1.96	1.96	1.96	1.95
	Skewness	0.03	0.06	0.06	0.04
	Kurtosis	3.00	3.00	3.01	3.01
200-230	Mean (A)	358.74	359.04	359.12	358.30
	Std. Dev. (A)	54.68	54.74	54.71	54.38
	Skewness	0.00	0.05	0.06	0.07
	Kurtosis	3.00	3.00	3.00	3.00
40-90	Mean (A)	207.29	207.73	207.93	207.36
	Std. Dev. (A)	37.66	37.81	37.80	37.61
	Skewness	0.00	0.09	0.10	0.12
	Kurtosis	3.00	3.03	3.04	3.04
60-100	Mean (A)	459.47	460.02	460.21	459.61
	Std. Dev. (A)	46.29	46.38	46.35	46.08
	Skewness	0.00	0.11	0.12	0.13
	Kurtosis	3.00	3.02	3.02	3.03

Table 2: Comparison of proposed linearization method and Monte-Carlo simulation results for circuit currents

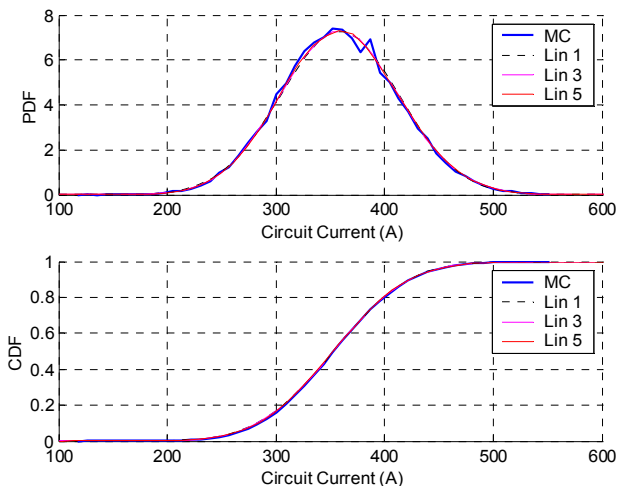

Figure 4. Comparison of proposed method and Monte Carlo simulation results. Probability Density and Cumulative Distribution Function of Circuit 200-230 current

		Proposed Method			MC
		1 Lin.	3 Lin.	5 Lin.	
20-40	Mean (A)	164.35	166.33	167.06	166.96
	Std. Dev. (A)	0.70	3.42	3.48	3.51
	Skewness	0.06	2.76	2.74	2.79
	Kurtosis	3.00	14.65	15.52	14.80
20-60	Mean (A)	185.02	186.05	186.38	186.48
	Std. Dev. (A)	3.53	3.82	3.87	3.77
	Skewness	0.06	1.70	1.76	1.81
	Kurtosis	3.00	7.21	6.94	7.45
70-80	Mean (A)	564.66	565.93	566.42	566.26
	Std. Dev. (A)	16.43	16.15	16.18	15.90
	Skewness	0.02	0.73	0.79	0.81
	Kurtosis	3.00	3.62	3.61	3.69
80-100	Mean (A)	76.05	77.72	78.66	78.77
	Std. Dev. (A)	31.68	30.06	29.35	28.74
	Skewness	0.01	0.60	0.71	0.77
	Kurtosis	3.00	3.14	3.22	3.25
160-190	Mean (A)	87.97	95.70	98.16	99.43
	Std. Dev. (A)	55.33	48.06	46.20	43.37
	Skewness	0.02	0.77	0.99	1.11
	Kurtosis	3.00	3.53	3.61	3.96

Table 3: Comparison of proposed linearization method and Monte-Carlo simulation results for circuit currents

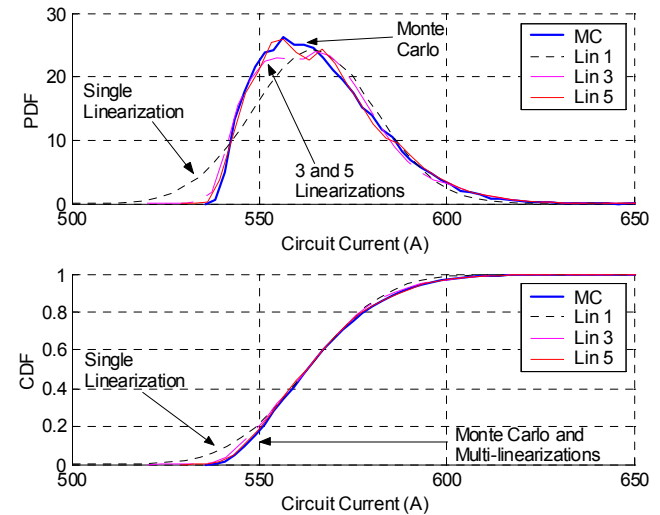

Figure 5. Comparison of proposed method and Monte Carlo simulation results. Probability Density and Cumulative Distribution Function of Circuit 70-80 current

6 CONCLUSION

This paper presented a new comprehensive methodology for probabilistic power flow analysis. The methodology is based on a stochastic non-conforming electric load model and it is applied on the quadratized power flow model of the system. It is capable of incorporating the operating practices and constraints of the power system. The methodology is useful in computing the expected performance of the system defined in terms of probabilistic distributions of bus voltage magnitudes, circuit flows and operating cost. The proposed method has been validated with an independent method based on Monte Carlo simulation. The current development and implementation of the methodology only takes into consideration load uncertainty. However, in the presented multi-linearization

framework other uncertainties can be easily incorporated like generation uncertainty, effects of possible network contingencies or uncertainties in system parameters.

The methodology is very useful in assessing the reliability of the electric power system. The recent several massive failures of the electric power grid with the most noticeable August 2003 blackout in US have generated renewed interest in the reliability of the power grid, because of the complexity of the system model and the complexity of the operating practices and constraints, it is necessary to develop methodologies that incorporate these issues. The proposed methodology is very promising towards this goal.

REFERENCES

- [1] R. R. Booth, "Power System Simulation Methods Based on Probability Analysis", *IEEE Trans. Power Apparatus and Systems*, vol. PAS-91, pp. 62–69, Jan./Feb. 1972
- [2] B. Borkowska, "Probabilistic load flow", *IEEE Trans. Power Apparatus and Systems*, vol. PAS-93, No. 3, pp. 752–759, May/June 1974
- [3] R. N. Allan, B. Borkowska, C. H. Grigg, "Probabilistic analysis of power flows", *Proc. of the IEE*, vol. 121, No. 12, pp. 1551–1556, Dec. 1974
- [4] R. N. Allan, C. H. Grigg, D. A. Newey, R. F. Simmons, "Probabilistic power flow techniques extended and applied to operational decision making", *Proc. of the IEE*, vol. 123, No. 12, pp. 1317–1324, Dec. 1976
- [5] R. N. Allan, M. R. G. Al-Shakarchi, "Probabilistic techniques in AC load flow analysis," *Proc. of the IEE*, vol. 124, No. 2, pp. 154–160, Feb. 1977.
- [6] R. N. Allan, M. R. G. Al-Shakarchi, "Linear dependence between nodal powers in probabilistic AC load flow," *Proc. of the IEE*, vol. 124, No. 6, pp. 529–534, June 1977.
- [7] R. N. Allan, A. M. Leite da Silva, and R. C. Burchett, "Evaluation methods and accuracy in probabilistic load flow solutions", *IEEE Trans. Power Apparatus and Systems*, vol. PAS-100, No. 5, pp. 2539–2546, May 1981
- [8] A. M. Leite da Silva, V. L. Arienti, R. N. Allan, "Probabilistic load flow considering dependence between input nodal powers", *IEEE Trans. Power Apparatus and Systems*, vol. PAS-103, No. 6, pp. 1524–1530, June 1984
- [9] J. F. Dopaso, O. A. Klitin, A. M. Sasson, "Stochastic load flows", *IEEE Trans. Power Apparatus and Systems*, vol. PAS-94, No. 2, pp. 299–309, Mar./Apr. 1975
- [10] R. N. Allan and A. M. Leite da Silva, "Probabilistic load flow using multilinearisations", *Proc. of the IEE*, vol. 128, Pt. C, No. 5, pp. 280–287, Sep. 1981
- [11] P. W. Sauer, G. T. Heydt, "A generalized stochastic power flow algorithm", presented at the IEEE/PES Summer Meeting, July 1978, Paper A78-544-9
- [12] A. M. Leite da Silva, R. N. Allan, S. M. Soares, and V. L. Arienti, "Probabilistic load flow considering network outages", *Proc. of the IEE*, vol. 123, Pt. C, pp. 139–145, May 1985
- [13] A. M. Leite da Silva, V. L. Arienti, and M. H. Barbosa, "Probabilistic techniques in load flow analysis – A practical application", *Proc. of 1st Int. Symp. Syst. (ISPMAEPS)*, Toronto, Canada, pp. 643–651, July 1986
- [14] A. M. Leite da Silva, S. M. P. Ribeiro, V. L. Arienti, R. N. Allan, and M. B. Do Coutto Filho, "Probabilistic load flow techniques applied to power system expansion planning", *IEEE Trans. Power System*, vol. 5, No. 4, pp. 1047–1053, Nov. 1990
- [15] A. M. Leite da Silva and V. L. Arienti, "Probabilistic load flow by multilinear simulation algorithm", *Proc. of the IEE*, vol. 137, Pt. C, No. 4, pp. 276–282, July 1990
- [16] M. Th. Schilling, A. M. Leite da Silva, R. Billinton, and M. A. El-Kady, "Bibliography on power system probabilistic analysis (1962–1988)", *IEEE Trans. Power Systems*, vol. 5, No. 1, pp. 1–11, Feb. 1990
- [17] A. P. Meliopoulos, A. G. Bakirtzis, R. Kovacs, "Power system reliability evaluation using stochastic load flows", *IEEE Trans. Power Apparatus and Systems*, vol. PAS-103, No. 5, pp. 1084–1091, May 1984
- [18] A. P. Sakis Meliopoulos, George J. Cokkinides, Xing Yong Chao, "A new probabilistic power flow analysis method", *IEEE Trans. Power Systems*, vol. 5, No. 1, pp. 182–190, Feb. 1990
- [19] A. P. Meliopoulos, X. Chao, George J. Cokkinides, R. Monsalvatge, "Transmission loss evaluation based on probabilistic power flow," *IEEE Trans. Power Systems*, vol. 6, No. 1, pp. 364–371, Feb. 1991.
- [20] A. P. S. Meliopoulos, S. Kang, G. J. Cokkinides and R. Dougal, "Animation and visualization of spot prices via quadratized power flow analysis", in *Proc. 36th Annu. Hawaii Int. Conf. on System Sciences*, 6–9 Jan., 2003, pp. 49–55
- [21] A. P. S. Meliopoulos, G. J. Cokkinides and R. Lasseiter, "A multiphase power flow model for μ Grid analysis", in *Proc. 36th Annu. Hawaii Int. Conf. on System Sciences*, Jan. 6–9, 2003, pp. 61–67
- [22] A. P. S. Meliopoulos, W. Gao, S. Li, G. J. Cokkinides and R. Dougal, "Quadratized induction motor model for power flow analysis", in *Proc. 2nd IASTED Int. Conf., EuroPES*, Crete, Greece, June 25–28., 2002, pp. 194–199
- [23] IEEE Committee Report, "IEEE Reliability Test System," *IEEE Trans. Power Apparatus and Systems*, vol. PAS-98, No. 6, pp. 2047–2054, Nov./Dec. 1979.