

POWER FLOW CONTROL BY MOBILE AGENT-BASED MANAGEMENT OF DISTRIBUTED ENERGY RESOURCES

Kenta Furukawa, Hiroumi Saitoh*
Tohoku University
Sendai, Japan
* saito@ecei.tohoku.ac.jp

Junichi Toyoda
Hachinohe Institute of Technology
Hachinohe, Japan

Abstract – In a future electric power system, there will exist a lot of distributed energy resources such as energy storage devices, renewable generation and cogeneration in the demand side. A system operator can utilize the distributed energy storage devices to control power flow of transmission networks and supply-demand balance concerned with bilateral transactions.

For management of such distributed energy storage devices, a mobile agent which can migrate in computer networks is available. This paper proposes an application of the mobile agent to management of the distributed storage devices for power flow control of transmission network. Management of distributed storage devices is done hierarchically. On the transmission-level, the system operator controls power flows by using a lot of distributed storage devices connected in distribution networks. On distribution-level, the mobile agent aggregates the information about such distributed storage devices and makes charge-discharge schedules of individual storage devices. The mobile agent is called Storage Device Management (SDM) Agent in this paper. A prototype of SDM Agent is developed by using Java language.

Keywords: mobile agent, intelligent system, energy storage device, optimal power flow, Java language

1 INTRODUCTION

In many countries in the world, deregulation in power industries has been done to reduce electricity price through introduction of competitive electricity market. In this context, power flow profile becomes more complicated because of many kinds of electricity transactions, so that it is important to maintain power throughput capability in any system conditions.

On the other hand, distributed energy resources such as energy storage devices, renewable generation and cogeneration are expected to load leveling, improvement of power quality, reduction of carbon dioxide and effective use of thermal energy. Distributed energy resources can be utilized for power flow control on transmission network by aggregating those resources with an intelligent system such as mobile agent.

Mobile agent is one of computer programs that can move from one computer to the other computers through communication networks such as the Internet, and which can process various kinds of tasks ordered by users of the agent such as solving optimization problems, searching data files, exchanging data with other agents and etc [1]. In the field of power systems, some applications of mobile agent have been studied in [2, 3].

This paper proposes an application of the mobile agent technology for management of distributed energy storage devices with the aim of controlling power flow on transmission network. Management of distributed storage devices by using the mobile agent is done hierarchically. On the transmission-level, the system operator controls power flows by using a lot of distributed storage devices connected in distribution networks. On distribution-level, the mobile agent aggregates the information about such distributed storage devices and makes charge-discharge schedules of individual storage devices. The mobile agent is called Storage Device Management (SDM) Agent in this paper.

In simulation studies, a prototype of the SDM agent is developed by using Java language. The function of the SDM agent is verified under a small LAN environment including several PCs in our laboratory. The result shows that the mobile agent is promised approach to control power flow in the future power system.

2 A FUTURE ELECTRIC POWER SYSTEM

2.1 Utilization of Distributed Energy Resources

The authors anticipate that many kinds of distributed energy resources such as energy storage devices, renewable generation and cogeneration are introduced by consumers, and are interconnected with existing distribution networks in future as shown Fig.1^[4,5]. If there exist many storage devices and enough surplus energy is stored, then the system operators which have responsibility of supervising overall system, can utilize the storage devices as one of the solutions to overcome power flow problems and supply-demand imbalance problems on transmission level.

When the system operator utilizes a lot of distributed storage devices, it is difficult for the operator to collect much information about storage devices and manage them efficiently. To overcome such difficulty, a new facility is required which can aggregate those storage devices located over geographically wide area in distribution networks. In this paper, such facility is called Power Router. In the future electric power system, the Power Router is installed at each distribution networks and manages distributed storage devices in individual distribution networks as shown in Fig.1. The Power Router needs three key functions to manage the distributed storage devices. One is to acquire the information about the stored energy of storage devices supervised by

the PR. The second one is to provide the system operator with the aggregated information about storage devices. The third one is to make charge-discharge schedules of individual storage devices.

2.2 The Necessity of Mobile Agent

Mobile agent is the computer program with the following features. One of the features is that mobile agent can move from one computer to the others, and can determine its destination based on the processing results obtained before the movement. In other words, by using mobile agent, the data acquisition system can be developed which can search and find autonomously the information required by users of agent. This feature is suitable for the implementation of the first and second function of Power Router described in the previous section. The other feature is that mobile agent can perform various kinds of tasks such as solving optimization problems and exchanging data with the other agents. This feature can be used for the implementation of the third function of Power Router. The mobile agent performing the three functions of Power Router is called Storage Device Management (SDM) Agent in this paper.

3 PROPOSAL OF POWER FLOW CONTROL BY STORAGE DEVICE MANAGEMENT AGENT

3.1 Hierarchical Strategy for power flow control

In order to control power flow in transmission network, the System Operator (SO) and the Power Router (PR) schedule charge-discharge actions of storage devices hierarchically as shown in Fig.2. SO determines power flow between transmission network and distribution network so as to reduce line overloading and supervise supply-demand balance concerned with bilateral transactions. Individual PR determines charge-discharge schedules of energy storage devices so as to achieve the power flow which is decided by SO. Fig.2 shows scheduling process of distributed energy storage devices by cooperative works between SO and PRs. Detailed and step-by-step actions of the hierarchical strategy are given below. Circled numbers listed below correspond with numbers in Fig.2.

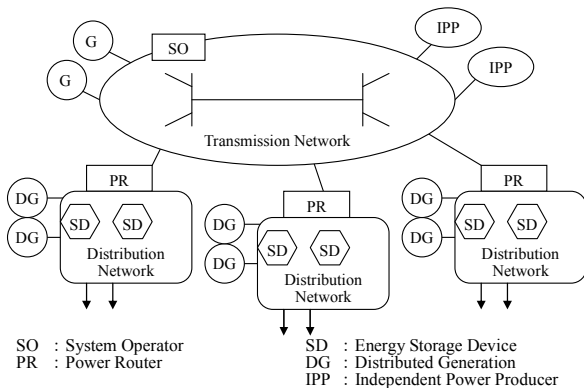

Figure 1: Configuration of a future electric power system.

- ① Request phase (transmission-level)
 First, SO requests all PRs to collect amount of energy storage functions of storage devices.
- ② Acquisition phase (distribution-level)
 Individual PR acquires data about distributed storage devices by using the SDM Agent. This data includes stored energy and limit charge or discharge power of storage devices.
- ③ Report phase (distribution-level)
 PR provides SO with the aggregated information about storage devices.
- ④ OPF phase (transmission-level)
 Based on the data reported from all PRs, SO determines power flows between distribution networks and transmission network by OPF calculation. That is macro schedules of storage devices groups so as to reduce line overloading and supervise supply-demand balance concerned with bilateral transactions.
- ⑤ Report phase (transmission-level)
 SO reports results of OPF calculation to all PRs and requests all PRs to provide energy storage functions aggregated by SDM Agent.
- ⑥ Allocation phase (distribution-level)
 Individual PR determines charge-discharge schedules of individual storage devices by using the SDM Agent so as to satisfy the SO's request.

3.2 Scheduling Process of Transmission-Level Power Flow pattern

SO determines power flow on transmission-level by OPF calculation based on the assumption that individual PR is a large storage device aggregated by SDM Agent. OPF problem which is solved by SO is formulated as follows.

$$\min_{\mathbf{P}_{PR}(t)} J(\mathbf{P}_{PR}(t))$$

$$J(\mathbf{P}_{PR}(t)) = (\mathbf{E}_{PR_i}(t+T) - \mathbf{E}\mathbf{c})^T (\mathbf{E}_{PR_i}(t+T) - \mathbf{E}\mathbf{c}) \dots(1)$$

$$\text{s.t. } \mathbf{E}_{PR}(t+T) = \mathbf{E}_{PR}(t) - T\mathbf{P}_{PR}(t) \dots(2)$$

$$|\mathbf{f}(\mathbf{P}_{PR}(t))| \leq \mathbf{f}_{\max} \dots(3)$$

$$\mathbf{f}(\mathbf{P}_{PR}(t)) = \mathbf{B}_L \mathbf{C} \mathbf{B}^{-1} (\mathbf{P}(t) + \mathbf{P}_{PR}(t)) \dots(4)$$

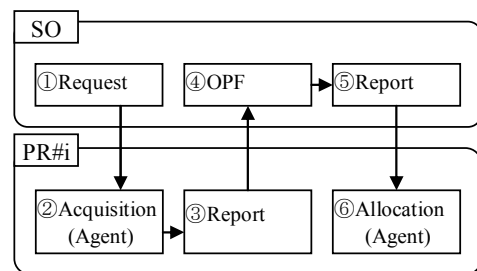

Figure 2: Scheduling process of distributed energy storage devices.

$$\mathbf{P}_{PR\min} \leq \mathbf{P}_{PR}(t) \leq \mathbf{P}_{PR\max} \dots\dots\dots (5)$$

$$\mathbf{0} \leq \mathbf{E}_{PR}(t+T) \leq \mathbf{E}_{PR\max} \dots\dots\dots (6)$$

$$\sum_i P_{PRi}(t) = - \left(\sum_i P_{Pi}(t) + \sum_i P_{Ci}(t) \right) \dots\dots\dots (7)$$

where,

$P_{PRi}(t)$ [MW]: inflow from distribution network (positive sign) or outflow (negative sign) to distribution network should be controlled by PR on bus #i at time t

$E_{PRi}(t)$ [MWh]: total energy of distributed energy storage devices of distribution network #i at time t

E_c [MWh]: target energy

T [hour]: time constant of control for P_{PR}

f [MW]: active power flow

f_{\max} [MW]: transmission capacity

B_L, B : line susceptance matrix, susceptance matrix

C : network connection matrix

$P_{Pi}(t)$ [MW]: power of producer concerned with bilateral transaction on bus #i at time t

$P_{Ci}(t)$ [MW]: power of consumer concerned with bilateral transaction on bus #i at time t

Eq.1 is an objective function, which is a sum of differences between target energy and stored energy at T hour later. In this paper, the target energy is set to a half of capacity. This is the way to retain charge-discharge function of storage devices managed by PRs. Energy of storage devices managed by PRs changes as Eq.2 with time. The inequality Eq.3 is transmission line power flow constraint. Transmission line power flow is formulated as Eq.4 by DC-flow method. The inequality Eq.5 represents limitation of P_{PR} . The inequality Eq.6 shows total energy limitation of storage devices. Eq.7 represents supply-demand balance concerned with bilateral transactions.

3.3 Management of Storage Devices by SDM Agent

Fig.3 shows the action of SDM Agent for data acquisition and charge-discharge scheduling of storage devices. It is assumed that every storage device have communication environment for SDM Agent, and SDM Agent know locations of storage devices such as IP Address in communication network. When SDM Agent is sent by PR, it goes around every storage devices and acquires data about capacity, stored energy and limit output or input power. When SDM Agent returns to PR, PR reports acquired data to SO as shown in Fig.3.

After SO reports inflow or outflow to PR by OPF calculation, SDM Agent allocates the power of inflow or outflow to energy storage devices to meet the requests from SO by solving following minimization problem.

$$\min_{\mathbf{Ps}} J(\mathbf{Ps}(t))$$

$$J(\mathbf{Ps}(t)) = (\mathbf{Ps}^*(t) - \mathbf{Ps}(t))^T (\mathbf{Ps}^*(t) - \mathbf{Ps}(t)) \dots\dots\dots (8)$$

$$\text{s.t.} \quad \sum_j P_{S_j}(t) = P_{PRi}(t) \dots\dots\dots (9)$$

$$\mathbf{Ps}_{\min} \leq \mathbf{Ps}(t) \leq \mathbf{Ps}_{\max} \dots\dots\dots (10)$$

$$\mathbf{Es}(t+T) = \mathbf{Es}(t) - T\mathbf{Ps}(t) \dots\dots\dots (11)$$

$$\mathbf{0} \leq \mathbf{Es}(t+T) \leq \mathbf{Es}_{\max} \dots\dots\dots (12)$$

$$\mathbf{Ps}^*(t) = \frac{1}{2}(\mathbf{Ps}_{\min} + \mathbf{Ps}_{\max}) \dots\dots\dots (13)$$

where,

$P_{S_j}(t)$ [MW]: charge power (negative sign) or discharge power (positive sign) of storage device #j at time t

Ps_{\min}, Ps_{\max} [MW]: upper limit and lower limit of Ps

$Ps^*(t)$ [MW]: target of charge-discharge power of storage device at time t

$P_{PRi}(t)$ [MW]: power flow requested from SO at time t (If positive, it means outflow to transmission network)

$Es(t)$ [MWh]: energy of individual storage device at time t

4 SIMULATION STUDIES

4.1 Power System Model and LAN used for Simulation

In order to verify the function of the SDM Agent, we developed the SDM Agent which works in a small LAN environment in our laboratory using Java language.

Fig.4 shows a power system model for verification of power flow control by SO and PRs. This model is

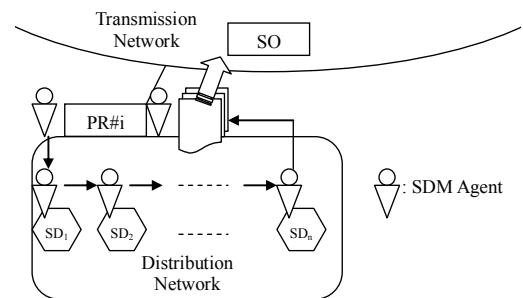

(a) ②Acquisition phase to ③Report phase (PR).

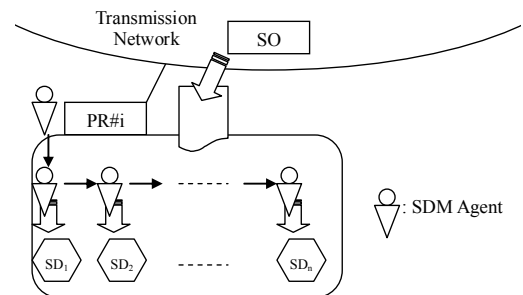

(b) ⑤Report phase (SO) to ⑥Allocation phase.

Figure 3: Actions of SDM Agent.

modified IEEJ-EAST10-model [6] to apply DC-flow OPF calculation. And it is assumed that three power producers make contracts of bilateral transactions with three consumers respectively as shown in Fig.4. Each transaction is driven as shown in top and bottom patterns in Fig.4. When those transactions start, a line overloading occurs on line #17-#31 in the direction of the arrow. For the overloading reduction, the system operator schedules inflows from the Power Routers. The Power Routers are installed at bus #18, #40, #41 and #47, which is dotted in Fig.4. Each Power Router manages four energy storage devices respectively.

A computer network environment in Fig.5 is assumed to be a communication system of SO, PRs and storage devices. Four Personal Computers (PC) are used for verification of SDM Agent. The system operator is assigned on PC1. The system operator program is so designed as to communicate with SDM Agents and calculate OPF on PC1. Four Power Routers are assigned on PC2. Actually, four Java programs for SDM Agents are executed on PC2. Storage devices are assigned on PC3 and PC4 as shown in Fig.5. Similarly, 8 Java programs assumed as storage devices are executed on PC3 and PC4 respectively. These PCs are connected in a local area network. SDM Agent is developed so as to communicate with SO on PC1 and migrate to PC3 or PC4 to acquire information of storage devices.

Capacities and initial energies of distributed energy storage devices are shown in Table 1. Storage device #1, #2, #5 and #6 are middle size. #3, #7, #11 and #15

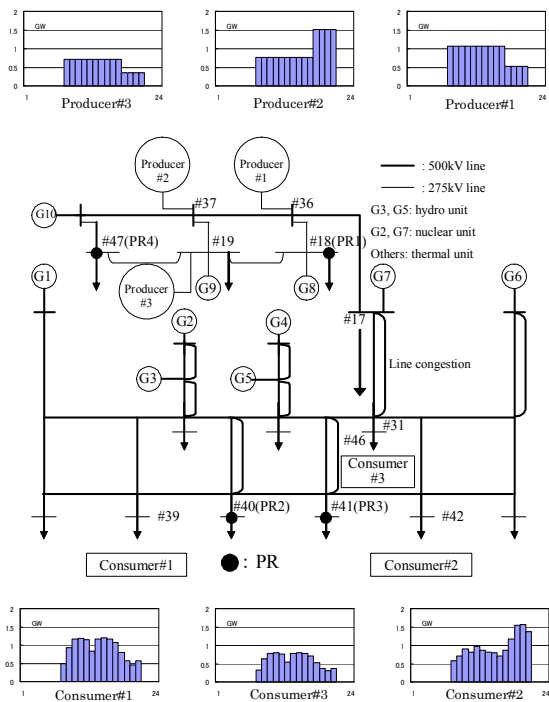

Figure 4: IEEJ East 10-machine system model including bilateral transactions.

Number of Storage Device	#1,#2, #5,#6	#3,#7 #11,#15	#4,#8 #12,#16	#9,#13	#10,#14
$E_{S_{max}}$ (p.u.MWh)	8	4	16	8	8
E_{S_0} (p.u.MWh)	4	2	8	1	7
$P_{S_{max}}$ (p.u.MW)	4	2	5	4	4
$P_{S_{min}} = -P_{S_{max}}$					

Table 1: Capacity and initial energy of distributed energy storage devices.

are small size. #4, #8, #12 and #16 are big size. These storage devices start with half energy of capacity. Storage device #9 and #13 are middle size and start with less energy. And it is assumed that much energy is stored in storage device #10 and #14.

4.2 Prototype of SDM Agent

Using above computer network, communication function between SO and SDM Agents is checked. Fig.6 shows computer screens from left to right, SO on PC1, PR#1 on PC2, storage device #1 on PC3. The circled numbers in Fig.6 correspond to the numbers in Fig.2.

First, SDM Agent created by PR#1 tries to connect with SO. Suppose that this SDM Agent called SDM Agent#1. When SO receives the connection from SDM Agent#1, acceptance message is displayed on the screen of PC1 as pointed by "Connection" in Fig.6. If all SDM Agents connect with SO, the system operator request unified information about distributed storage devices to SDM Agents as shown at "①Request" in Fig.6. At same time, waiting message is displayed on PC1. The SDM Agent who receives the request from SO acquires information about distributed storage devices, and then displays the information on PC2 as shown at "②Acquisition" in Fig.6. SDM Agent reports acquired data to SO ("③Report"). When all SDM Agents report the data to SO, SO executes OPF calculation. After that, SO reposts schedules of inflow from PRs to SDM Agents ("⑤Report"). Finally, individual PR allocates the power to the storage devices using the SDM Agent in order to control power flow between distribution network and transmission network requested from SO ("⑥Allocation phase").

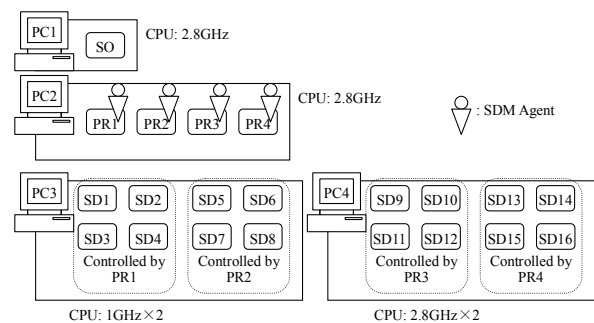

Figure 5: Computer network environment for SDM agent.

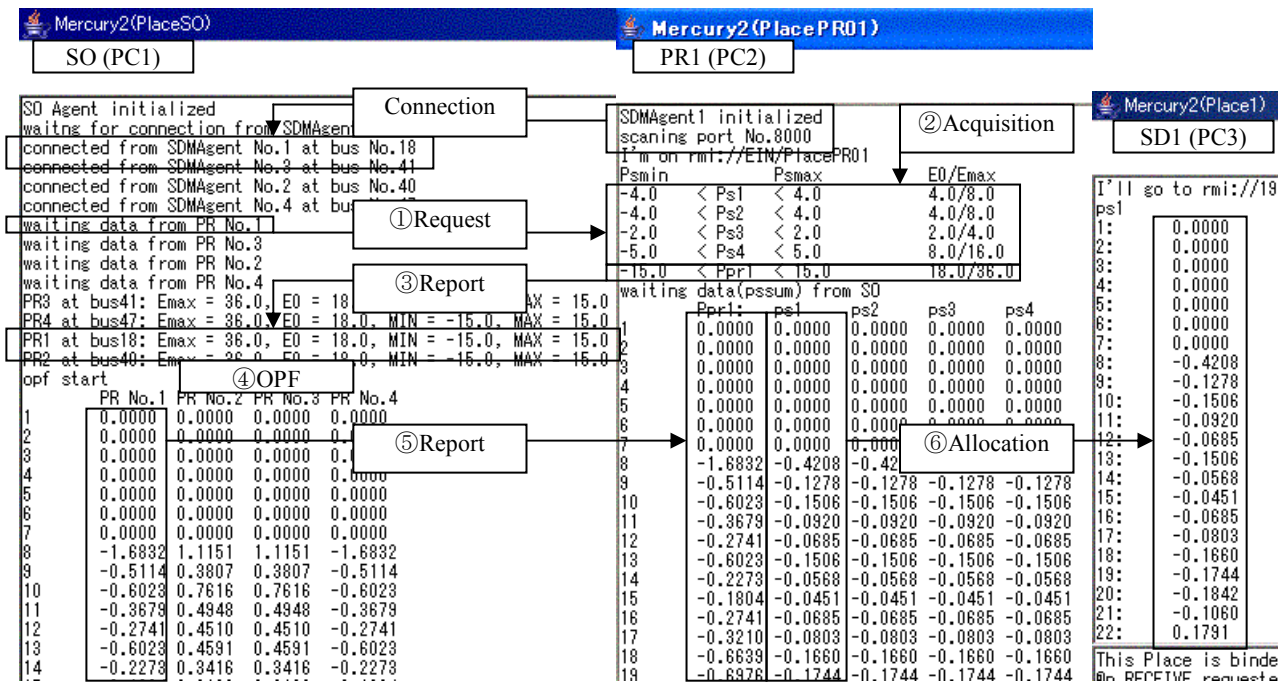

Figure 6: Computer screens of the system operator, Power Router #1 and storage device #1.

4.3 Result of Storage Device Scheduling

Simulation studies following three cases were done to verify the power flow control function of SO.

- Case 1: Without bilateral transactions.
- Case 2: Including three bilateral transactions with-out power flow control function of SO.
- Case 3: Including three bilateral transactions with power flow control function of SO.

Fig.7 shows power flow patterns of above 3 cases. In case 1, there is no line overload, therefore power flow don't need controlling. In case 2, three bilateral transactions occur line overload from 8a.m. to 9p.m. SO has to reduce the line overload in this case.

Fig.8 shows input-output power flow patterns of PRs and variations in energies of storage devices at simulation case 3. From 8a.m. to 9p.m., PR#2 and PR#3 discharge, on the other hand, PR#1 and PR#4 charge to reduce line overload. Fig.7 (c) indicates that inflow control by PRs in Fig.8 (a) control power flow on the line #17-#31 to 12p.u.MW. These actions decrease energy of storage devices controlled by PR#2 and PR#3, and increases energy of storage devices controlled by PR#1 and PR#4 as shown in Fig.8 (b).

From 9p.m. on the first day to 8a.m. on the second day, there is no line overloading as shown in Fig.7 (b). However, when PRs control power flow, line power flow at this time increases up to limit power flow. This phenomenon is caused by energy adjustment action of PRs. PR#2 and PR#3 that discharge during line overloading have to charge energy for next day. Con-

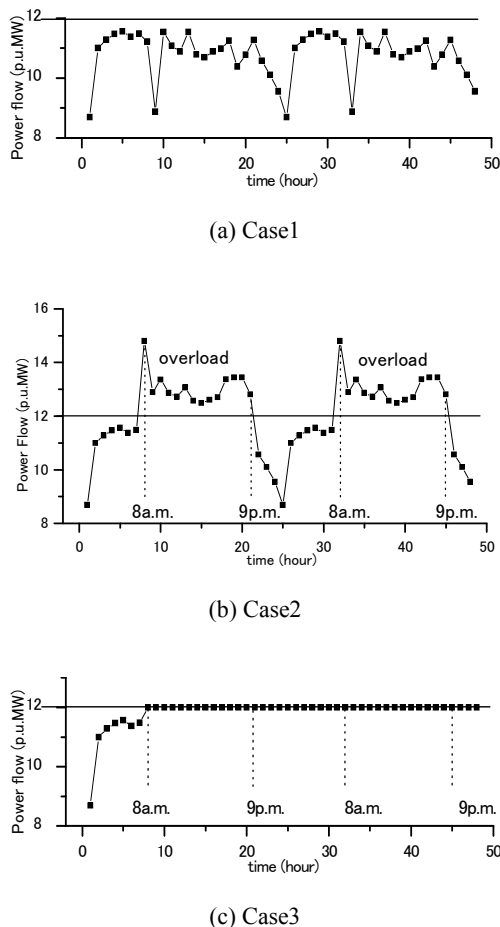

Figure 7: Power flow on the line #17-#31.

versely, PR#1 and PR#4 that charge during line overloading have to reduce energy of storage devices. Fig.8 (b) shows that PRs' energy return to near by initial energy at 8a.m. on the second day.

Fig.9 shows charge-discharge schedules and variations in energy of storage devices #9, #10, #11 and #12 controlled by PR#3. These charge-discharge patterns are scheduled so as to satisfy SO's request by SDM Agent#3.

5 CONCLUSIONS

This paper proposed an application of mobile agent for hierarchical management of distributed energy resources such as storage devices for power flow control. In the simulation, it is verified that SDM Agent can execute designed functions such as migration for data acquisition and calculation for charge-discharge scheduling of storage devices in a small LAN environment. Although the simulation environment was a small LAN, the results shows that mobile agent is promising to aggregation of distributed energy resources for power flow control in the future power system.

For the implementation of the proposed management system, there are several problems which should be resolved. One of the problems is that highly efficient and low-cost storage devices should be developed and used by many consumers, because many storage devices are required to control power flow on transmission level. The other problem is how the individual storage devices are controlled by using mobile agent through communication system. In this paper, scheduling process of storage devices is only discussed. It is necessary to develop control strategy of the storage devices. The final one is how to give the economical incentives to owners of storage devices to draw cooperation for power flow control on transmission level.

The further works are the development of learning ability of mobile agent for flexible scheduling of storage devices and the development of cooperation ability of mobile agent to obtain the feasible solutions of power flow problems on transmission level.

REFERENCES

- [1] V. Anh Pham, A. Karmouch, "Mobile Software Agents: An Over View", IEEE Communications Magazine, Vol.36, No.7, pp26-37, 1998
- [2] K. Furukawa and H. Saitoh, "An Application of Mobile Agent for Power Flow Control of Open Electric Energy Network", Proceedings of the 2004 IEEE International Conference on Electric Utility Deregulation, Restructuring and Power Technologies (DRPT 2004), Volume: 2, pp.774-779, Apr. 2004
- [3] T. Otani, "System Configuration and QoS Control of Mobile Agents for a Next-generation of Distribution System", IEEJ Trans. EIS, Vol.124, No.3, pp921-928, 2004 (in Japanese)
- [4] K. Furukawa and H. Saitoh, "An Application of Mobile Agent for Optimal Power Flow Control using

Decentralized Energy Storage Devices", Joint Technical Meeting on Power Engineering and Power Systems Engineering, Japan, PE-04-106, PSE-04-106, pp.25-30, Sep. 2004 (in Japanese)

- [5] H. Saitoh, S. Miyamori, T. Shimada and J. Toyoda, "An Autonomous Decentralized Control Mechanism for Power Flow in an Open Electric Energy Network", Electrical Engineering in Japan, Vol.121, No.4, pp.28-37, 1997
- [6] Japanese Power System Models. [Online]. Available: <http://www/iee.or.jp/pes/model/english>.

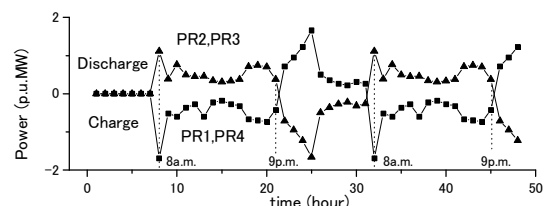

(a) Power

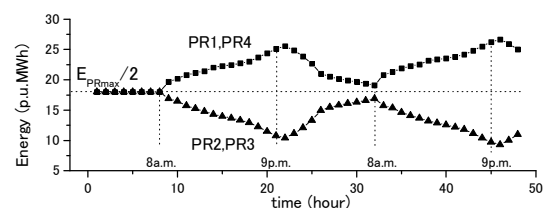

(b) Energy

Figure 8: Input-output power flow of PRs and energy of energy storage devices.

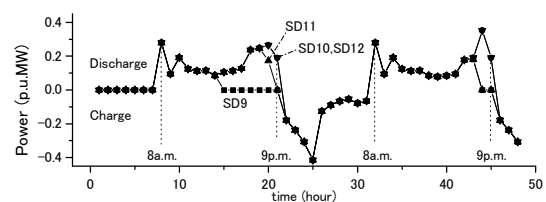

(a) Power

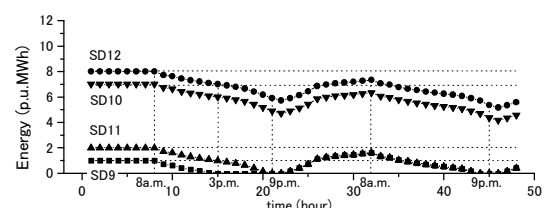

(b) Energy

Figure 9: Charge-discharge schedules and energy of storage devices controlled by PR3.