

A NEW APPROACH TO ASSESS THE VALUE OF REACTIVE POWER PRODUCTION

H. MORENO
Supélec
Gif-sur-Yvette, France
hugo.moreno@supelec.fr

G. GUTIERREZ
ITMorelia/ISU
Méx./ USA
ggutier@iastate.edu

S. PLUMEL
Supélec
Gif-sur-Yvette, France
sophie.plumel@supelec.fr

P. BASTARD
Supélec
Gif-sur-Yvette, France
patrick.bastard@supelec.fr

G. B. SHEBLE
Iowa State University
Ames, USA
gsheble@iastate.edu

Abstract – In a deregulated electricity market, Ancillary Services are essential for the adequate operation of the bulk power system. In order to procure reactive power support, it is necessary to quantify the value of the VAR's available sources within the system. This paper focuses on reactive power supply and voltage control on transmission networks. An optimization approach is proposed to determine the minimum total cost of reactive power support. The variation of the minimum amount of reactive power (Q_{th}) required by a given generator to deliver its own active power is taken into account. The optimization program is formulated as linear programming problem and is solved using MATLAB® and JPélec©. The interaction between active and reactive power for accurate calculation of generators' reactive power capacity is also evaluated. The proposed method is tested with a 13-bus test system and the 24-bus CIGRE network.

Key words: reactive power valuation, ancillary services, power grid.

1 INTRODUCTION

The structural reform of the electric energy sector introduces real competition between producers in the whole European Community. This requires definitions of new mechanisms to allocate and to incentive power producers to provide reactive power services taking into account that the control of voltage profile and overcoat of reactive power issues is made only by the Transmission System Operator (TSO).

In a deregulated electricity market, the procurement and remuneration of Ancillary Services (AS) plays an important role. AS are essential for the adequate operation of the bulk power system. As part of AS policies, it is desirable to find a mechanism to motivate the producers to contribute to the voltage control in order to avoid lack of service. Several methods to achieve these objectives have been proposed.

1.1 Former work

Many authors have approached the topic of voltage support as an AS and have opted for different methods and considerations to dispatch reactive power and also to assess reactive power production.

In [1], a cost function structure is proposed and solved by OPF for reactive power by a two part conformed method. The authors propose a reactive power market with a new reactive power offers structure. An analysis of the cost of reactive power support is presented in [1]. For each generator, an

opportunity cost analysis and a methodology for the dispatching is proposed.

In [3], a method to assess the amount of avoided VAR compensation means on a grid is presented. A value is assigned to the reactive power production according to the amount of VAR compensations needed to compensate the lack of reactive power production by each existing generator. The added compensator means are supposed to maintain the same degree of network security. The concept called the value curve is introduced.

In [4], the authors established the importance for a generator to provide reactive power in order to deliver active power to the consumers. This minimum amount of necessary reactive power is calculated according to system conditions and depends on the active power production of a generator and the distance to the load center. A detailed analysis of the minimum amount of reactive power a generator needs to produce to supply its active power production is presented. The authors state that each generator needs a certain amount of reactive power to support the transmission of its own active power. In fact, compensation to a generator's reactive power output should be made only to the amount that is above this minimum quantity of reactive power (Q_{min}) and allows the generator to begin to contribute to the voltage control service.

In [5], an OPF (Optimal Power Flow) of reactive and active power considering the congestion problem is proposed. The method divides the system into active and reactive zones and defines Power Transfer Distribution Factors (PTDF) both for active and reactive power.

1.2 Context of the paper

In order to procure reactive power support at minimum cost, it is necessary to know the cost of the VAR's available sources in the system. An optimization approach is proposed to determine the minimum total cost of reactive power support. The optimization program is formulated as linear programming problem and it is solved using MATLAB® and JPélec© [11]. In order to linearize the equations, optimal reactive power is scheduled using a sensitivity matrix. The interaction between active and reactive power for accurate calculation of generators' reactive power capacity is also evaluated. The variation of the minimum amount of less-remunerated reactive power (called Q_{th} in this paper) required by a given generator to deliver its own active power is taken into account [2]. The analysis was

performed only for the case of supply. The case of absorption needs to be evaluated.

The capability curve of every generator is considered in the OPF constraints.

The capacitors banks have been assigned an equal cost function equation. To model uncertainty in the reactive power demand, a Monte Carlo technique is used. For each level of load, the most probable optimal reactive power procurement plan is evaluated by using a reactive OPF. The proposed method is tested with a simple test system and then with a normalized network.

The method provides useful information to the TSO to select zones with the same price level and assign a reactive power value.

2 FORMULATION

Several authors propose sensitivity analysis as a tool to relate the reactive power production to the voltage variation in every bus of the system [3,6,8].

2.1 Sensibility matrix:

At bus i , sensibility of reactive power provided by generator j is given by:

$$s_{ij} = \frac{\Delta V_i}{\Delta Q_j} \quad (1)$$

Technically, a sensibility equal to zero shows that voltage at node i is insensible to the variations of reactive power produced by generator j . On the contrary, a big sensibility signs dependency of the voltage at node i to a reactive power production of generator j . In fact, it is depending on the location of the slack node, which balances production and consumption both in active and reactive power. But this problem could be solved by the following process: forcing the value of the active and reactive powers at the slack node to zero [13]. It could be done by dispatching (OPF) the production/consumption of active power at the slack node on the other producers. Concerning the reactive power, the value at the slack node can be forced to zero by controlling the voltage at this bus.

The sensibility matrix was obtained with thanks to the full load flow simulator JPélec, which is coupled with Matlab.

The sensibility matrix is computed as follows:

1. All generator busses are PV controlled for the first calculation of load flow.
2. Setting all the generators to PQ controlled busses, with the reactive power calculated in the previous step.
3. Elimination of active and reactive production of the slack bus. The active power reaches zero by re-dispatching using an OPF of active power with losses minimization. The reactive power in the slack bus is controlled by changing the reference voltage at this bus.
4. A load flow is computed to obtain initial voltage values.
5. Increment of $\Delta Q_j = 1 \text{ MVAR}$ (for example) of the reactive power produced by a generator

(every generators are studied one after the other).

6. Setting to zero the reactive power production at the slack node by iterating the 3rd step.
7. All the values of voltage are obtained, and voltage variations can be computed.
8. The sensibility matrix is obtained:

$$\text{Sensibility matrix} = \begin{bmatrix} \frac{V_1}{\Delta Q_1} & \frac{V_2}{\Delta Q_1} & \dots & \frac{V_i}{\Delta Q_1} \\ \vdots & \vdots & \ddots & \vdots \\ \frac{V_1}{\Delta Q_j} & \frac{V_2}{\Delta Q_j} & \dots & \frac{V_i}{\Delta Q_j} \end{bmatrix} \quad (2)$$

2.2 Cost function

We have to define the cost function of each generator for its production of reactive power. It is assumed to be nonlinear, with a less-remunerated base. Every generator produces at its marginal cost and this one is constant [2][7]. Figure 1 presents the proposed cost function for the generators. It is assumed that TSO can construct a cost function that takes into account a payment for capacity each generation unit.

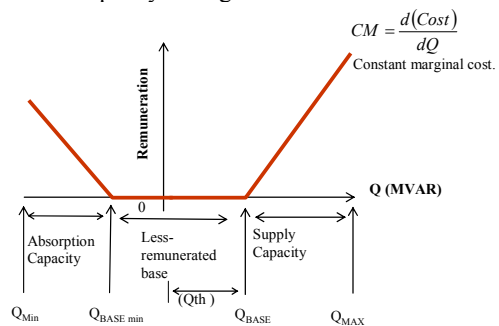

Figure 1: Cost function reactive power production

The cost function for the capacitor banks is constant and equal to its marginal cost.

2.3 Definition and calculus of Q_{th} .

Q_{th} is defined as the minimal amount of reactive power needed from each generator to maintain the voltage control. It should expect remuneration from TSO [2].

The methodology used in this article is the same as the one proposed in [2]. A polynomial of the second degree that relates the active power production of every generator to the Q_{th} will be obtained. In this article we propose to consider as a constraint that the value of Q_{th} is variable in the OPF of reactive power production. In absorption Q_{th} is fixed. A curve as the one shown in figure 2 is expected to be obtained for every generator.

2.4 Capability curve of the generator

Figure 3 represents a capability curve of a generator that takes in account the constraints. In the same figure, we observe that the relationship between the reactive power and the active power has as boundaries both lines composed between Q_{max} and P_{oa} , Q_{oa} and P_{ob} . It is assumed that TSO knows this curve.

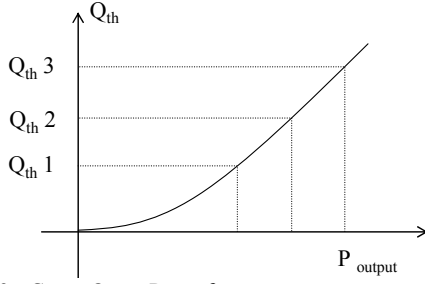

Figure 2: Curve Q_{th} vs P_{output} for every generator.

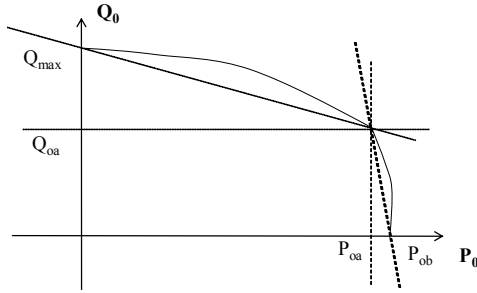

Figure 3: Capability curve for a generator.

The constraint for optimization is the following:

$$P_o < P_{oa} \quad (3)$$

$$Q_{omax} = Q_{max} + (((Q_{oa} - Q_{max}) / P_{oa}) * P_o)$$

$$P_o > P_{oa} \quad (4)$$

$$Q_{omax} = Q_{oa} + (((-Q_{oa} / (P_{ob} - P_{oa})) * (P_o - P_{oa})))$$

where P_o is the active power production in MW.

The maximum capacity of reactive power injection for each generator Q_{max} is calculated as a function of the maximum active power capacity, P_{max} . It is assumed that: $Q_{max} = 0.32 P_{max}$ and $Q_{min} = -0.35 P_{max}$.

For the Q_{th} in absorption an equal value is fixed for all the generators.

3 OPTIMIZATION

3.1 Active Power

An OPF of active power is done, its objective function is to minimize the production cost, the transmission congestion is taken in account in the constraints using of the Power Transfer Distribution Factors (PTDF) [12].

$$\min \sum_{i=1}^{Gq} (CM_i \cdot P_i) \quad (5)$$

The real PTDF's are defined as the ration variation (ΔP_{ij}) in the k^{th} transmission line which connects bus- i to bus- j , due to variation in the power injections (ΔP_n) at any bus n .

$$PTDF_n^k = \frac{\Delta P_{ij}}{\Delta P_n} \quad (6)$$

From (6) we can obtain a PTDF matrix that relates every line of the test system with each active power

injection (MW). The constraint for optimization is the following:

$$\Delta P_{ij}^{min} \leq PTDF_g^k * \Delta P_g \leq \Delta P_{ij}^{max} \quad (7)$$

where ΔP_g is the variation of active power production for the g^{th} generator.

$$\sum_g P_g = \sum_d P_d + losses \quad (8)$$

where P_g is the active power production of the g^{th} generator and P_d is the active power consumption of the d^{th} consumer.

Equation (8) establishes the balance between demand and generation. The optimization implicates that the optimal solution is found with a losses minimization.

3.2 Reactive power

The cost minimization is expected.

$$\min \sum_{i=1}^{Gq} (CM_i Q_i + CF_i) \quad (9)$$

where Gq is the number of sources of reactive power in the test systems, CM_i is the marginal cost of the i -th source of reactive power, Q_i is the quantity of reactive power given by the i -th source of reactive power and CF_i is the fixed cost of the i -th source of reactive power.

The inequality restrictions are of the following form:

$$A \cdot X \leq B$$

$$V_k \leq V_{max_k}, k \in [1, N] \quad (10)$$

$$V_k \geq V_{min_k}, k \in [1, N]$$

$$V_k = V_{k0} + \left(\frac{\Delta V_k}{\Delta Q_1} \right) \Delta Q_1 + \dots + \left(\frac{\Delta V_k}{\Delta Q_{Gq}} \right) \Delta Q_{Gq}, \quad (11)$$

$$k \in [1, N], k \neq n$$

where N is the number of buses of the system, V_k is the voltage magnitude at bus k , and V_{k0} is the initial voltage magnitude at bus k . More explicitly:

$$V_{k0} + \sum_j \frac{\Delta V_k^j}{\Delta Q_j} \cdot \Delta Q_j \leq V_{max_k} \quad (12)$$

$$V_{k0} + \sum_j \frac{\Delta V_k^j}{\Delta Q_j} \cdot \Delta Q_j \geq V_{min_k}$$

where V_{k0} is the initial voltage at bus k , ΔV_k^j is the voltage variation at bus k for a variation of the reactive power production in bus j ΔQ_j , the ratio $\frac{\Delta V_k^j}{\Delta Q_j}$ is available in the sensibility matrix, V_{max_k} , V_{min_k} are the

bounds of voltage at bus k , and ΔQ_j is the increase of reactive power production at bus j .

$$\begin{aligned} 0 \leq Q_1 \leq Q_{th} & \quad R_1 = 0 \\ Q_{th} \leq Q_2 \leq Q_{max} & \quad R_2 = CM_s \\ Q_{thmin} \leq Q_3 \leq 0 & \quad R_3 = 0 \\ Q_{min} \leq Q_4 \leq Q_{thmin} & \quad R_4 = CM_a \end{aligned} \quad (13)$$

where CM_s is the marginal cost for reactive power supply and CM_a the marginal cost for reactive power absorption.

In equation (13) the cost function is split into 4 parts in order to linearize the problem. 4 variables (Q_1 to Q_4) associated to 4 constant remunerations (R_1 to R_4) are defined.

In this case A is the sensibility matrix; X is the solution that represents the re-dispatching of the reactive power with regard to the original ones. B is a vector of maximum voltage in every bus.

The upper and lower limits of the variable to search are:

$$Q_{min} - Q_0 \leq (Q - Q_0) \leq Q_{max} - Q_0 \quad (14)$$

Then in the problem there will not be equality constraints.

In this article, it is supposed that the active power has been predetermined using an OPF.

3.3 Final process

The result of the active power optimization is loaded in the test system to optimize it in terms of reactive power. The process is continued until the result of the optimization converges.

The figure 4 presents the flow diagram of the proposed method.

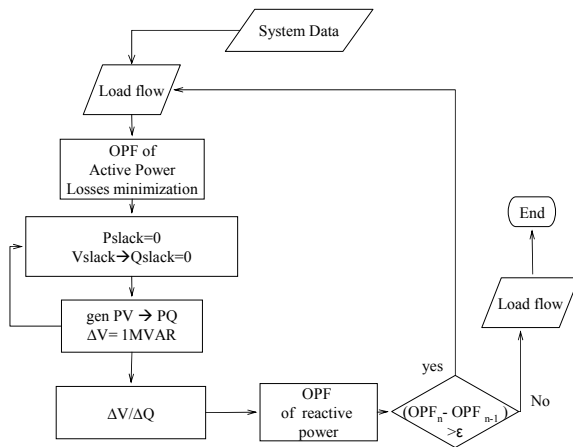

Figure 4: Flow diagram of reactive power optimization

3.4 Uncertainty in reactive power demand

A normal probability distribution function is considered to simulate the uncertainty of the reactive power demand. Three different conditions are assumed, medium, maximum and minimum values of reactive

power demand. A production curve is obtained for the reactive power of each generator. The optimal solution for each Monte Carlo simulation sample is calculated using the methodology detailed above.

4 SYSTEM STUDIES

The proposed method is first tested with a simple test system and then with a normalized network.

4.1 Example for 13 buses test system

The figure 5 presents a test system with 4 generators, 6 loads and a capacitors bank. The operative voltage level is 400 kV.

The active power OPF and the reactive power OPF have been obtained following the formulation of equations (5) to (14). Q_{th} calculus is presented for each generator of the system.

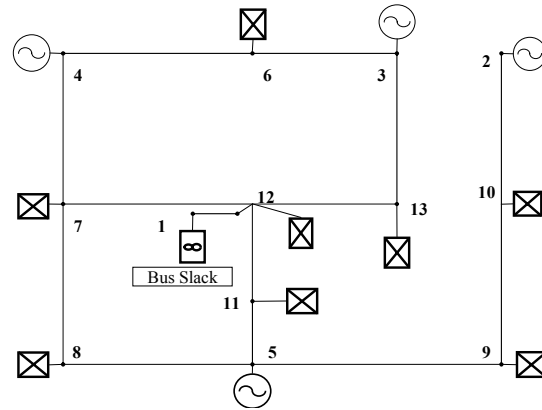

Figure 5: 13-bus system

Table 1 presents the values obtained for initial conditions after the active power OPF and elimination of the slack bus influence. The voltage limits are $V_{max} = 420$ kV and $V_{min} = 365$ kV.

Bus Number	Voltage In	CM*	MW Max	MW Min	MW	Q _{max}	Q _{min}
1	398.50						
2	400.00	50	1000	300	470.66	variable	variable
3	400.00	90	2000	300	380.55	variable	variable
4	400.00	60	1000	300	470.66	variable	variable
5	400.00	100	1500	300	470.66	variable	variable
6	393.57						
7	394.40						
8	394.91						
9	393.33						
10	391.22						
11	396.82						
12	398.45						
13	396.73						

*MU: Monetary unit

Table 1: Initial conditions for reactive power OPF

The figure 6 shows that the generator connected to bus 2 has a part of negative Q_{th} . In facts, it is necessary established that for the calculation of any negative Q_{th} , its value is automatically set to zero.

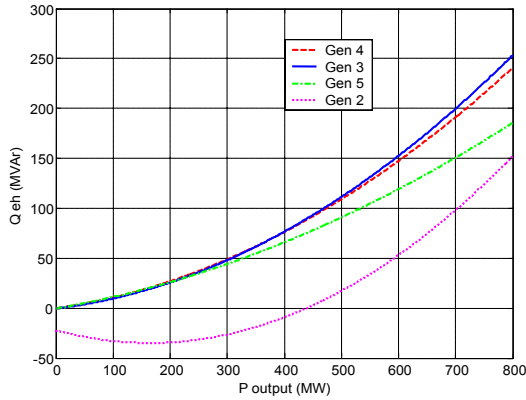

Figure 6: Curve Qth for 13-bus system

Tables 2 and 3 show the system data.

Bus Number	Minimum		Medium		Maximum	
	MW	fp	MW	fp	MW	fp
6	252	0.90	224	0.90	280	0.90
7	315	0.90	280	0.90	350	0.90
8	180	0.80	160	0.80	200	0.80
9	315	0.95	280	0.95	350	0.95
10	180	0.85	160	0.85	200	0.85
13	180	0.90	160	0.90	200	0.90

Table 2: Bus data of 13-bus system.

From Bus	To Bus	R (Ω/km)	X (Ω/km)	Y/2 (μF/km)	Length (Km)
4	7	0.05	0.4	0.01	100
4	6	0.05	0.4	0.01	100
6	3	0.05	0.4	0.01	100
7	12	0.05	0.4	0.01	100
5	9	0.05	0.4	0.01	100
10	9	0.05	0.4	0.01	100
2	10	0.05	0.4	0.01	50
8	5	0.05	0.4	0.01	50
8	7	0.05	0.4	0.01	100
11	5	0.05	0.4	0.01	50
12	11	0.05	0.4	0.01	100
1	12	0.05	0.4	0.01	0.001
13	3	0.05	0.4	0.01	100

Table 3: Circuit data of 13-bus system.

Table 4 presents the optimal solution for the dispatching of reactive power after the heuristic treatment with initial load whereas.

Bus Number	V optimal	MW (OPF)	MVAr (OPF)
1	398.42		
2	400.00	466.00	117.27
3	400.00	385.92	8.2786
4	400.00	470.76	27.851
5	400.00	470.76	66.570
6	393.57		
7	394.38		
8	394.90		
9	393.35		
10	391.24		
11	396.81		
12	398.43		
13	396.71		
Cost*			
Losses	13.66 MW		

*MU: Monetary unit

Table 4: Optimal solution test system

Table 5 the results with differ load conditions system are shown. The differences between the MW column of table 1 and the MW (OPF) column of table 4 (initial load) are due to the re-dispatching of reactive power which generates a different amount of active losses.

Note that only variable costs are taken into account. In the first simulation, a null cost is obtained, because the optimal reactive production is into the limits of Q_{th} .

The optimum production in initial conditions has null costs. It means that all the generators produce inside of the base of no-remuneration

Bus Number	+25 Load			+40% Load		
	V optimal	MW (OPF)	MVAr (OPF)	V optimal	MW (OPF)	MVAr (OPF)
1	406.71			417.84	0	0
2	373.02	590.19	83.925	371.57	661.87	55.251
3	420.23	477.55	116.15	420.18	535.74	62.541
4	415.45	590.19	97.812	417.91	661.87	70.824
5	399.85	590.19	138.73	415.48	661.87	310.55
6	409.68			409.56		
7	401.73			409.15		
8	397.29			408.35		
9	378.71			385.9		
10	365.29			365.26		
11	398.48			412.23		
12	406.71		25	417.8		100
13	409.97			414.78		
Cost *		24.858			151.58	
Losses		23.17			29.77	

*MU: Monetary unit

Table 5: Optimal solution test system differs load condition

Figure 7 shows utilization of reactive power production expected for each generator after the heuristic treatment. It is possible to observe that generator 5 is the most used at the +40% load. In this case, a zone of similar price can be defined for generators 2, 3 and 4. This figure allows visualizing the reserve margin for each generator.

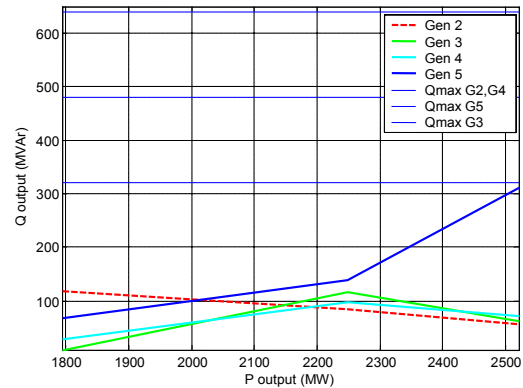

Figure 7: Reactive power production for each generator

Note that in figure 7 the 3 simulation points (initial, +25%, +40% load) have been interpolated.

4.2 Example for 24-bus system (CIGRE)

The software used for the load flow calculation is limited in the number of PV-nodes. The method proposed in this paper is tested with a normalized 24-bus test system. However, at this time the proposed algorithm is being adapted to be used with commercial

software in order to perform OPF studies with large networks. The results of this analysis will be reported in further publications.

Systems Data are available in [10]. Figure 8 represents the system's single line diagram. A supplementary line has been added to join bus 2 (slack node) to bus 17. This changes the number of buses from 24 to 25. A capacitor bank of 300 MVar is connected to the system at bus 24. In this system there are 10 generators with different capacities. The 24-bus system has two different voltage levels, the transmission voltage (230 kV) and sub-transmission voltage (13.8kV).

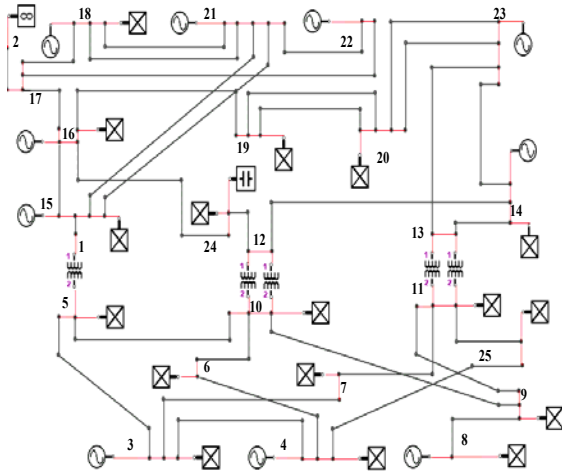

Figure 8: 25 buses Test system (CIGRE modified)

Figure 9 shows that only 4 out of 10 generators have a positive Q_{th} .

In this example it is assumed that each generator is capable to generate a minimum of $0.32 P_{max}$ of reactive power, when it needs to product P_{max} . Consequently, the conditions of the capability curve have been established.

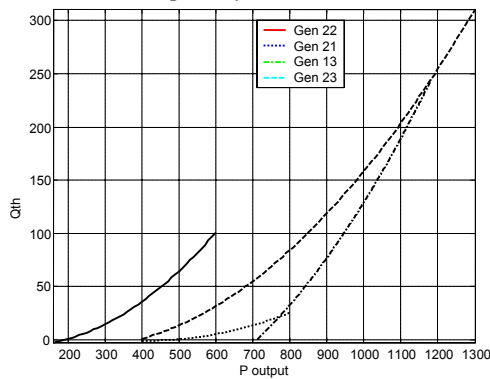

Figure 9: Curve Q_{th} for 24 bus test system CIGRE

Table 6 presents the GICRE 24-bus system data after the reactive power OPF. In table 7 the results under two different load conditions are presented. These results have been obtained with an accepted voltage range of +5%/-10% of nominal voltage.

Bus Number	MW (OPF)	MVAr (OPF)	Q_{th}	Q_{max}
16	310.00	99.2		99.20
21	400.00	218.60		646.40
22	600.00	30.50	100.99	192.00
14	706.96	56.91		881.17
3	384.00	91.44		122.88
4	384.00	70.39		122.88
8	600.00	152.56		192.00
23	1320.00	264.36	322.73	422.40
15	430.00	137.60		137.60
18	400.00			640.00
24		300.00		300.00
Cost *				
Vslack (kV)				

*MU: Monetary unit

Table 6: Results of the OPF reactive power for the test system CIGRE

Bus Number	MW (OPF)	MVAr (OPF)	Q_{th}	Q_{max}	MW (OPF)	MVAr (OPF)	Q_{th}	Q_{max}
16	310	99.2		99.2	160	100.6		250.4
21	429.4	284.2		635.1	400			646.4
22	600	25.77	100.9	192	600	145.1	100.9	192
14	1182	354.1	244.5	378.2	480	72.23		977.7
3	384	105.3		122.8	384	88.76		122.8
4	384	78.75		122.8	384	59.48		122.8
8	600	159.2		192	600	137.0		192
23	1320	221.9	322.7	422.4	946.4	145.9	136.5	929.8
15	430	137.6		137.6	430	137.6		137.6
18	429.5			628.2	400			640
24		300		300		300		300
Cost *		4.9 e4				1.76e7		
V slack		225.92 kV				224.17 kV		

*MU: Monetary unit

Table 7: Results of the OPF reactive power for different load conditions

Figure 10 shows the amount of reactive power produced by each generator. It shows for example that Gen 22 is not requested much. Additionally, Gen 14 as the load increases becomes essential for the voltage (and reactive) support, due to the localization of the capacitors bank (node 24).

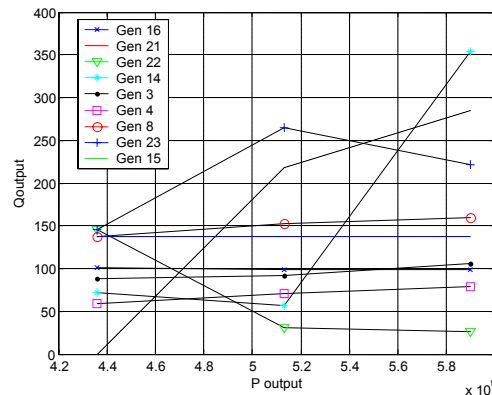

Figure 10: Production expected for each generator

As a consequence, generators connected at buses 4, 3,16,15,21 may be in the same remuneration area. Generator 16 decreases its reactive production as the load increases. In fact, generator 14 supports the reactive needs. Generator 23 and 8 could be remunerated in similar way. The difference, in this case, is that Genera-

tor 23 can still be remunerated for the reactive reserves. Generator 18 is never requested.

5 CONCLUSIONS

The main contribution in this article is the idea of combining the OPF based procedure with the calculation of the minimum amount of reactive power needed from each generator to maintain the security level of the system. To do this, the introduction of variable Q_{th} (different for each generator) as a constraint to reactive OPF problem is proposed. The level of remuneration for the participant diminishes because the reactive production needed to control the voltage is often less than Q_{th} . This method allows tracing the curve of daily-expected reactive power production plan in a network operated in stable condition. The remuneration level can be calculated using the utilization percentage of each generating unit.

In the minimum load conditions, all generators supply reactive power. We did not simulate a load conditions in which reactive power absorption is needed. Further work will be done to include such condition

In most of the cases, the quantity of reactive power that must be remunerated is void or very small since Q_{th} is very near to Q_{max} . Thus, the TSO can manage to fulfill the constraints of the optimization without leaving the limits of Q_{th} . However, in the GIGRE system, several generators do not have positive Q_{th} . In this case, TSO would have to remunerate these generators from the first produced MVar at the variable cost.

The utilization graphics (figures 7 and 10) allow calculating the needs in reactive power production of all generators. The margin of reserve and the eventuality that certain generators will be operated near their maximum capacity may also be easier to be determined using these figures. The utilization graphic is obtained, taking into account Q_{th} and Q_{max} according to the capability curve of the generator.

The remuneration of the capacitors bank is considered as generator of reactive power but without variable cost. In the practice only its capacity is remunerated.

Zones of similar price can be defined by comparing the utilization ratio of all reactive producers.

The linear optimization program was first solved by MATLAB and JPelec©. Then, the problem was modeled with the GAMS modeling language. The final results are very similar. Computational execution time differs because in the first case, an iterative process is executed between MATLAB and JPelec©. In the second case, the problem is also modeled sequentially. However, there is no need for data transfer which implies a time reduction.

Perspectives to the present work are to obtain these graphs of utilization under N-1 contingencies to assess the value of reactive power reserve.

REFERENCES

- [1] Kankar Bhattacharya and Jin Zhong, "Reactive Power as an Ancillary Service", IEEE Trans. On power Systems, vol. 16, No.2, May.2001. pp. 294-300.
- [2] Jonh W. Lamont, Jian Fu, "Cost Analysis of Reactive Support," IEEE Trans. on Power Systems, Vol. 14, No.3 August 1999. pp. 890-898.
- [3] W. Xu, Y. Zhang, L.C.P. da Silva and P. Kundur, "Assessing the value of generator reactive power support for transmission access," IEE Proc. Gener Transm. Distrib., Vol 148, No.4 July 2001. pp. 337-342.
- [4] Yuanning Wang, Wilsun Xu, "An Investigation on the Reactive Power Support Service Need of Power Producers", IEEE Trans. on Power Systems, vol. 19, No. 1 February 2004. pp. 586-692
- [5] Ashwani Kumar, S. C. Srivastava and N. Singh, "A Zonal Congestion Management Approach Using Real and Reactive Power Rescheduling," IEEE Trans. On power Systems, vol. 19, No. 1 February 2004. pp. 554-562.
- [6] John Peschon, Dean S. Piercy, Willian F. Tinney, "Optimum Control Reactive Power Flow," IEEE Trans. On power apparatus and Systems, January 1968, Vol pas 87, No. 1. pp. 40-47.
- [7] P. Sakis Meliopoulos, Murad A. Asa'd, G.J. Cokkinides, "Issues for Reactive Power and Voltage Control Pricing in a Deregulated Environment," Proc. of the 32 Hawaii Int. Conf on Syst. Scien., 1999. pp 1-6.
- [8] Kenji Iba, Hiroshi Suzuki, Ken-ichi Suzuki, Katsuhiko Suzuki, "Practical Reactive Power Allocation / operation planning using successive linear programming", IEEE Trans. On Power Systems, Vol 3, No. 2 May 1988. pp. 558-566
- [9] Seshadri P S, A.D. Patton, "Bus Voltage Sensitivity: An Instrument for pricing voltage control service", IEEE Trans. On Power Systems, Vol 3, May 1999. pp. 703-707
- [10] "Methods and tools for costing ancillary services," Task Force 38.05.07 June 2001 CIGRE. pp. 69-73.
- [11] S. Deladreue, P. Bastard, "A new tool to deal with uncertainty in the emerging electricity market structure", Proc. RIMAPS 2001, Porto, September 2001.
- [12] F. L. Alvarado, "Solving power flow problems with a Matlab implementation of the power system applications data dictionary Source," Proceedings of the 32nd Annual Hawaii International Conference on Systems Sciences. 1999. HICSS-32. 1999, p 7 pp.
- [13] P. Yan, "Modified distributed slack bus load flow algorithm for determining economic dispatch in deregulated power systems," in Proc. IEEE Power Eng. Soc. Winter Meeting, 2001, pp. 1226-1231.