

# Integrated Optimal FACTS Allocation With Power System Stability Constraint

C. Unsihuay  
Federal University of Itajubá  
MG, Brazil  
unsihuay@ieee.org

R. C. Leme  
Federal University of Itajubá  
MG, Brazil  
leme@iee.efei.br

A. C. Zambroni de Souza  
Federal University of Itajubá  
MG, Brazil  
zambroni@iee.efei.br

J. W. Marangon Lima  
Federal University of Itajubá  
MG, Brazil  
marangon@iee.efei.br

M. A. Tomim  
University of British Columbia  
Vancouver, Canada  
marcelo@ece.ubc.ca

**Abstract** - Due the economic and technique importance of power systems operation, it is necessary to formulate static and dynamic constraints in the optimal FACTS allocation problem. This paper proposes an integrated framework for allocating optimal series compensation considering both static and dynamic stability constraints. The proposed method consists of two sequential and interactive stages: (i) allocation procedure, in order to assess the optimal series compensation allocation in the network and (ii) feedback control input signals selection for the series compensation degree, to maintain the small signal stability margin in an acceptable range. For these tasks it is used an optimal series compensation stage formulated as a mixed integer nonlinear programming problem for large dimensions, and a small signal stability assessment in the sense of subsynchronous resonance (SSR) employing a new index based on the geometric mean of the absolute values of dominant eigenvalues of the Jacobean matrix and the number of eigenvalues with positive real part. Simulations and analysis using a 6-bus test system are carried out, which verifies the quality of the implemented approach, rendering the proposed methodology as effective.

**Keywords** - *FACTS devices, series compensation, power system stability, optimal power flow, interior point method, investment cost.*

## 1 INTRODUCTION

DEregulated markets for electric for electric energy associated whit social and economic constraints created an environment whit more restrict stability and security margin [1], affecting both generations and transmission operation and planning scenarios. For instance, due to environment constraints, transmission lines are more difficult to be built nowadays, thus resulting in a need for transmission system operation with the highest possible levels of efficiency [2]. Hence, there is an interest in better utilization of available capacities by installing Flexible AC Transmission Systems (FACTS) devices such as thyristor-controlled series compensators, thyristor-controlled phase angle regulators and unified power flow controllers. These devices, by controlling the power flows in the network, can help to reduce the flows in heavily loaded lines, resulting in an increased loadability, low system loss, improved stability of the network, reduced cost of production and fulfilled contractual requirement. The possibility of con-

trolling power flow in an electric power system without generation rescheduling or topological changes can improve the performance considerably [9]. In this context, it is important to ascertain the optimal location for placement of these devices because of their considerable costs and their impact on the static and dynamic power system performances.

Many works in optimal allocation of FACTS devices have been presented using optimization with different objective functions, algorithms and models. The objective functions studied and presented in the literature are : overall operation cost minimization[3], [4], [5] system loadability maximization, [7], [6] [8], congestion management[9], optimal reactive power dispatch [10], and others. Since FACTS devices improve static and dynamic power system security many works also focus exclusively on this problem. In, [11], [12], and [13] FACTS allocation was allocated to improved the static power system security. Applications of these devices for improving the dynamic performance and security of the system are also well documented in [15], [16], [17], and [18]. In addition of the voltage collapse problems are discussed in [19]. Although the optimal FACTS allocation may slightly influence the dynamic stability of the power system, it may still compromise the system security. Most of the mentioned works do not consider both static and dynamic problem in an integrated form. Thus, it is important to develop an optimal power flow considering FACTS and small signal stability of power systems as constraints all together. Few researches have been reported concerning this problem, which provides more realistic solutions. However, more recently, in [18] it was reported an interesting work which includes the voltage-stability constraint during the VAR planning using FACTS.

Besides, series capacitive compensation in electrical power systems is generally recognized as a very economical and powerful means for increasing long-distance transmission lines capability. However, when a series capacitor is connected to the transmission system, subsynchronous resonance (SSR) may arise, mainly if there are thermal generating units connected to the system. This is related to the many masses of the turbine-generator shafts, which oscillate in frequencies mostly below the synchronous one [20]. Hence, an analysis considering this phenomenon becomes crucial when series compensation planning is performed using FACTS devices.

The above discussion shows clearly the importance to formulate the static and dynamic constrains of power systems operation for optimization of economically and technically (security) allocation of FACTS in the network.

This paper presents an integrated framework for choosing the optimal series compensation degree and location, considering small signal stability analysis as a constraint during the optimization process. The optimal allocation is performed using the interior point method and the small signal stability is assessed using a new index based on the geometric mean of the absolute values of dominant eigenvalues of the Jacobian matrix and the number of eigenvalues with positive real part. Simulations using a 6-bus test system are carried out, which verifies the validity and feasibility of the implemented approach, rendering the proposed methodology as effective

## 2 MATHEMATICAL MODEL

In this paper, the main interest relies on optimizing the transmission capacity given an available operating point originated, for instance, from an optimal economic dispatch [3]. Then the transmission system capability is increased by re-distributing the power flows through optimal series compensation in the network considering, in addition, their impact on dynamic stability of power system. This objective function would be a special case of transmission system planning, where the system loadability would be improved only by optimal series compensation allocation. As with all preliminary studies of transmission system planning the objective function is more related to active power flows, the optimization problem algorithm considers a dc power flow model as tradeoff between accuracy and tractability.

### 2.1 Series Capacitor Model

The following series capacitor representation is suitable to perform the steady-state analysis with dc load flow model. Fig. (1) shows a branch, representing a transmission line  $i$ , with susceptance  $\gamma_i$  in series with an susceptance  $\Delta\gamma_i$  due the capacitive compensation.

Besides,  $\gamma_i = 1/X_i$ , where  $\gamma_i$  and  $X_i$  is susceptance and reactance of transmission line  $i$ , respectively.

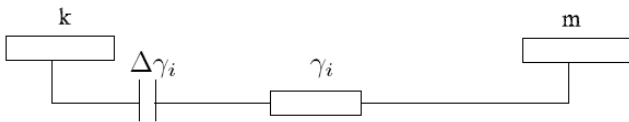

**Figure 1:** Model of series compensator in transmission line  $i$  connecting buses  $k$  and  $m$

The dc active power flow  $P_{km}$  through the transmission  $i$  is a function of total susceptance ( $\gamma_i + \Delta\gamma_i$ ) and the phase angle between buses  $k$  and  $m$ :

$$P_{km} = (\gamma_i + \Delta\gamma_i)(\theta_k - \theta_m) \quad (1)$$

Considering then the series compensation in this transmission line, the new total transmission line reactance  $X_i^{new}$  is:

$$X_i^{new} = \frac{1}{1/X_i + \Delta\gamma_i} \quad (2)$$

Thus, the the value of series capacitive compensation in terms of capacitance is as follows:

$$\Delta X_i = X_i^{new} - X_i \quad (3)$$

To avoid the over compensation, the operating range of the series compensator may be defined as done in [4]:

$$0 \leq \Delta\gamma_i \leq \Delta\gamma_i^{max} \quad (4)$$

where,

$$\Delta\gamma_i^{max} = \min\left(\frac{1}{0.3X_i}; \Delta\gamma_i^{stbmax}\right) \quad (5)$$

And  $\Delta\gamma_i^{stbmax}$  is due to the small signal stability constraint. In this case, the value  $\frac{1}{0.3X_i}$  is adopted because levels of passive series compensation higher than 70% can produce intense long-lasting oscillations in the system. Regarding FACTS, higher series compensation degrees can be achieved, as long as an adequate control system is implemented [4].

### 2.2 Objective Function

The objective function in this paper is to minimize the overall cost ( $US\$/year$ )[3] of installing the series compensation:

$$CT_{sc} = \sum_{i=1}^L C_{sc_i}(\Delta\gamma_i) \quad (6)$$

Where:  $L$  is total number of installed series compensators,

$$C_{sc_i} = (VCF_i + IC_i/\Delta\gamma_i) \quad \forall \Delta\gamma_i \neq 0 \quad (7)$$

$$C_{sc_i} = VCF_i \quad \forall \Delta\gamma_i = 0 \quad (8)$$

Furthermore, the series compensation cost in line  $i$  is given by [3]:

$$VCF_i = c \frac{(\bar{f}t_i)^2}{BP} \frac{1}{\gamma_i^0(\gamma_i^0 + \Delta\gamma_i^0)} \quad (9)$$

Where,  $c$  is a positive constant that represents the series compensator cost. In this paper it is assumed 26.3  $US\$/MVar \cdot year$ ;  $\bar{f}t_i$  is the thermal limit of line  $i$ ,  $BP$  is the base power (100 MVA);  $\gamma_i^0$  is the susceptance of transmission line  $i$  without the series compensation. Last but not least  $IC_i$  is the installation cost of a series compensation at line  $i$  [3].

### 2.3 Small Stability Analysis

When a series capacitor is installed, for example in a hydro thermal power system, an electromechanical analysis which considers the SSR becomes necessary because of possible harmful interactions between the capacitors and mechanical systems (turbine-generator shafts) that may come up. Hence, the analysis of the problem related to SSR requires a system approach which considers, at least, lumped parameters modeling for transmission network, the electromechanical dynamics of generators and the interaction between them provided by the transformer

effect in the generators. This way, the system order increases, making the analysis very complex [20].

At first, each generator is modeled by a flux model as presented in [20]. A general expression which models a synchronous machine is outlined in the equations (10) and (11). The electrical network state equations can be computed from the graph theory, as described in [21], which assume the form presented in (12), when referred to a  $dq$ -frame which rotates at the synchronous frequency.

Finally, the mechanical system featured by the turbine shafts coupled to the generators and their innumerable pressure stages must be modeled, so all the significant oscillation modes are represented. For this task a lumped spring-mass model is used, as shown in Fig 2. It assumes the shaft may be divided into finite inertia segments ( $H$ ) connected by springs ( $K$ ) and damping dashpots ( $D$ ), which represent the elastic and the mechanical hysteresis properties of the shaft, respectively. The damping dashpot, which is represented from each turbine mass to the fixed reference frame, is due to the viscous friction between the turbine blades and the work fluid (steam damping). The state equations of the turbine shaft may be obtained from the Newton's law for rotational bodies [22], which can be sketched by a equation similar to (14).

$$\dot{V}_{dq} = -RI_{dq} - \dot{\Psi} + V_{\omega} \quad (10)$$

$$\Psi_{dq} = L_{dq}I_{dq} \quad (11)$$

$$\dot{\mathbf{x}}_{dq} = A_{dq}\mathbf{x}_{dq} + B_{1dq}\mathbf{u}_{Gdq} + B_{2dq}\dot{\mathbf{u}}_{Gdq} \quad (12)$$

$$\mathbf{y}_{dq} = C_{dq}\mathbf{x}_{dq} + D_{1dq}\mathbf{u}_{Gdq} + D_{2dq}\dot{\mathbf{u}}_{Gdq} \quad (13)$$

$$\mathbf{x}_M = A_M\mathbf{x}_M + B_M\dot{\mathbf{u}}_M \quad (14)$$

In the equations (10) and (11)  $V_{dq}$ ,  $I_{dq}$ ,  $\Psi_{dq}$ ,  $V$ , represent voltages, currents, flux linkages and speed voltages of the machine all referred to its  $dq$ -frame, respectively. The  $R$  and  $L$  are matrices that contain the machine parameters, like resistance and inductance. In equation (12) the vector  $\mathbf{x}_{dq}$  is constituted by capacitor voltages and inductor currents. The vector  $\mathbf{y}_{dq}$  represents the network output variables, which gather all generators terminal voltages. The vector  $\mathbf{u}_{Gdq}$  is formed by voltage and current sources, all referred to  $dq$ -frame of the network. The matrices  $A_{dq}$ ,  $B_{1dq}$  and  $B_{2dq}$  are the state and input matrices, while  $C_{dq}$ ,  $D_{1dq}$  and  $D_{2dq}$  are the output and the feed-forward matrices. All these matrices depend on the topology and nature of the system. For further details in power systems modeling concerning SSR see references [21] and [27].

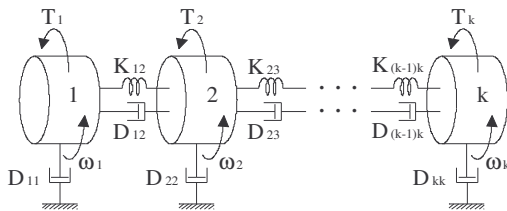

Figure 2: Spring-mass model the turbine shaft coupled to the generator.

Moreover, it is known from the dynamic systems stability theory that the behavior of a given non-linear system, as described in (15), at a critical point  $\mathbf{x}_0$ , is similar to the behavior of the same system linearized, as shown in (16), at  $\mathbf{x}_0$ .

$$\dot{\mathbf{x}}_{dq} = f(\mathbf{x}, \mu) \quad (15)$$

$$\Delta\dot{\mathbf{x}}_{dq} = J(\mathbf{x}_0, \mu_0)\Delta\mathbf{x} \quad (16)$$

$J(\mathbf{x}_0, \mu_0)$  is the jacobian matrix of the system at  $\mathbf{x}_0$ . The variable  $\mu_0$  represents a parameter responsible for changes in the structure of the system under study.

If  $J(\mathbf{x}_0, \mu_0)$  presents only eigenvalues with negative real part, the original non-linear system is locally stable at  $\mathbf{x}_0$ .

When  $J(\mathbf{x}_0, \mu_0)$  has only one pair of purely imaginary eigenvalues, and all others having non-zero real part the Hopf bifurcation takes place. At this point  $\mathbf{x}_0$  will correspond to the bifurcation value of the system [23], [24].

As electromechanical stability and SSR system models will be analyzed regarding Hopf bifurcation in this work, transmission line series compensation established by the optimization program will be adopted as the parameter. The index proposed in [25] to identify Hopf bifurcations is used in this paper. This index is given by equation (17). A reduced set of eigenvalues is calculated by the refactored bi-iteration [26], chosen as a function of the oscillation modes of the shafts. This information is obtained based on the previously known natural frequencies among other shaft torsional data [27]. Consider the set  $\Sigma = \sigma_1, \sigma_2, \dots, \sigma_i$ , where  $\sigma_i$  are associated with the real parts of a reduced set of dominant eigenvalues of the Jacobian matrix.

$$IND = \begin{cases} \sqrt[n]{\prod_{i=1}^n |\sigma_i|} \Rightarrow \{\sigma_i \in \Sigma / \sigma_i > 0\} = \phi \\ -\sqrt[n]{\prod_{i=1}^n |\sigma_i|} \Rightarrow \{\sigma_i \in \Sigma / \sigma_i > 0\} \neq \phi \end{cases} \quad (17)$$

If  $\Sigma = \{\sigma_i \in \Sigma / \sigma_i > 0\}$  is a null set, all the eigenvalues of  $\sigma_i$  present negative real parts, and  $IND$  is positive, yielding asymptotic stability of the system. Otherwise, if  $\Sigma = \{\sigma_i \in \Sigma / \sigma_i > 0\}$  is non-null,  $IND$  is negative, indicating instability of the system.

### 3 Integrated Optimal FACTS Allocation With Power System Stability Constraint

The mathematical formulation of the increasing the transmission system capability through optimal series compensation allocation considering its impacts on dynamic stability of power system is formulated as nonlinear optimization problem of a large dimension. In order to performing this problem in this paper are conducted in two sequential and interactive steps, and it can be expressed as follows:

Step 1)

$$\text{Minimize : } CTsc = \sum_{i=1}^L Csc_i(\Delta\gamma_i) \quad (18)$$

subject to

$$D(\theta, \Delta\gamma) = 0 \quad (19)$$

$$|F(\theta, \Delta\gamma)| \leq F^{max} \quad (20)$$

$$0 \leq \Delta\gamma \leq \Delta\gamma^{max} \quad (21)$$

Let the optimal series compensation found step 1 be  $\Delta\gamma^*$   
Step 2)

- Run AC power flow:  $f(\Delta\gamma^*, z) = 0$
- From 10%  $\Delta X_i$  to 100%  $\Delta X_i$  assess  $IND(\Delta X_i, z)$
- Found an  $\Delta X_i^{max_{stb}}$  such as  $IND(\Delta X_i, z) \in \text{stable/instable bound}$ .

• Assess :

$$\Delta\gamma_i^{max_{stb}} = \frac{1}{\Delta X_i^{max_{stb}} + X_i} - \frac{1}{X_i} \quad (22)$$

- $\min(IND(\Delta X_i, z)) > 0$ , then end, else go to step 1.

Where:

$D(\theta, \Delta\gamma)$  : the conventional dc power flow equations considering the transmission losses.

$F(\theta, \Delta\gamma)$  : the inequality constraints for series compensator and transmission power flows.

$\Delta\gamma, \theta$  : vectors that represent the variables of series compensator and bus angles, respectively.

$z$  : represent the static and dynamic operating state of the system.

$IND(\Delta X_i, z)$ : a power system stability index according to eq. (17).

Notice that, the cost component (18) related to the series compensation devices, is a nonlinear function of the susceptance variation. Since, with the introduction of series compensation, the susceptances vary, problem (19) also becomes a nonlinear function of the susceptance variation [3]. It makes step 1 a nonlinear programming problem of a large dimension. For solving the optimization problem of step 1, in this paper is used linear successive programming using interior points method. The first step performs the optimal facts allocation considering the objective function and all the static constraints. Then, in the second step a detailed study on small signal stability using the operating point provides by first step is executed. In this second step includes a detailed ac power flow model. Then, this second step provides to the first stage a feedback control input signals selection for the series compensation degree, in order to maintain the small signal stability margin at an acceptable level such as treated in section 2.3.. The steps 1 and 2 is executed until the optimal series compensation is found and the systems operating point is stable.

## 4 Numerical Results

### 4.1 Test system

The proposed framework was implemented in Matlab language. In order to verify the effectiveness in suitable and more comprehensive manner a small 6-bus test system [28] is used in this paper. Moreover, to obtain some transmission lines overflowed and an instable operating point was necessary to withdraw two transmission lines (line 1-5 and line 2-4) from original test system. The fig. 3 shows this modified 6 bus test system.

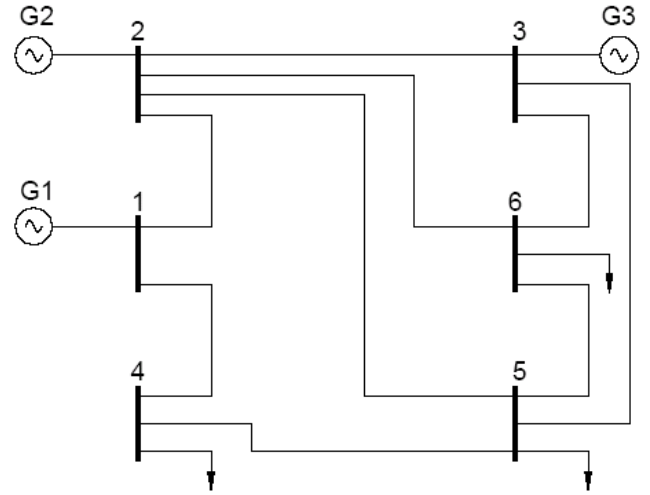

Figure 3: Modified 6-bus test system

### 4.2 Test Results

Table 1 presents results of optimal series compensation allocation with power system stability constraint for case studied for each iteration. Fig. 4 and 5 shows the  $IND$  values at first iteration and second iteration, respectively. One can notice that simulation for the studied system converged only in two iterations. In this modified test system for case base operating point only the line 1-4 is overflowed and the system is instable. It is showed at column 3, 4, 5 and 8, at first iteration row.

The maximal value of series compensation at lines are according the eq. (5). Notice that in first iteration only a series capacitor of 0.126 p.u. is allocate at branch 1-2. However, for this value, the system turns unstable and the computation of  $IND$  takes place according to step 2. It provides  $\Delta X_i^{max_{stb}}$  (which is 73.8 % of  $\Delta X_i$ ), and consequently,  $\Delta\gamma_i^{max_{stb}}$ . This fact is showed in the fig. 4.

The  $\Delta\gamma_i^{max_{stb}}$  is used, on the second iteration, as a new restriction for step 1. A new allocation of 0.125 p.u. is considered in the branch 2-5. For this condition, the system is stable and the process is concluded. Figure 5 shows  $IND$  for this iteration. One can also see that at the first iteration the total cost is lower than the second one. In other hand, at the second iteration the framework provides a stable operation point, which is the optimal solution based on a combined static and dynamic point of view.

| Iter. | Branch from-to | Flow Limit (MW) | Case base Flow (MW) | Actual flow (MW) | $\Delta\gamma^{max}$ p.u. | $\Delta\gamma^{max}_{stab}$ p.u. | IND      | $\Delta\gamma^*$ p.u. | $\Delta X^*$ p.u. | Tot. Cost $\times 10^6$ US\$/yr |
|-------|----------------|-----------------|---------------------|------------------|---------------------------|----------------------------------|----------|-----------------------|-------------------|---------------------------------|
| 1     | 1 - 2          | 35              | 27.93               | 30.323           | 16.66                     | Inf.                             | Instable | 8.695                 | - 0.126           | 0.421703                        |
| 1     | 1 - 4          | 70              | 72                  | 70               | 16.66                     | -                                | -        | -                     | -                 | -                               |
| 1     | 1 - 2          | 35              | 27.93               | 30.323           | 16.66                     | 4.319                            | Stable   | 4.319                 | - 0.092           | 0.659588                        |
| 1     | 1 - 4          | 70              | 72                  | 69.99            | 16.66                     | -                                | -        | -                     | -                 | -                               |
| 2     | 2 - 5          | 40              | 32.20               | 36.651           | 11.11                     | Inf.                             | -        | 2.389                 | - 0.125           | -                               |

**Table 1:** Results of optimal transmission line series compensation for each iteration.

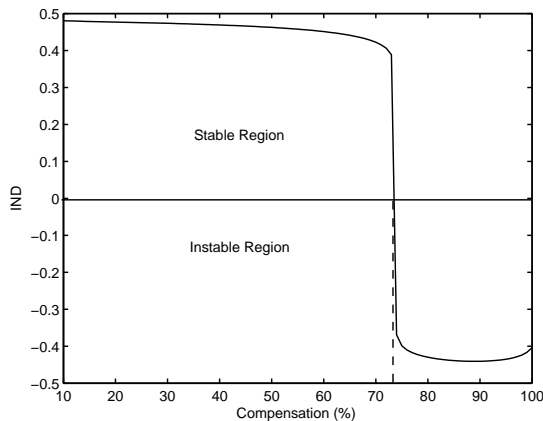

**Figure 4:** IND values at first iteration.

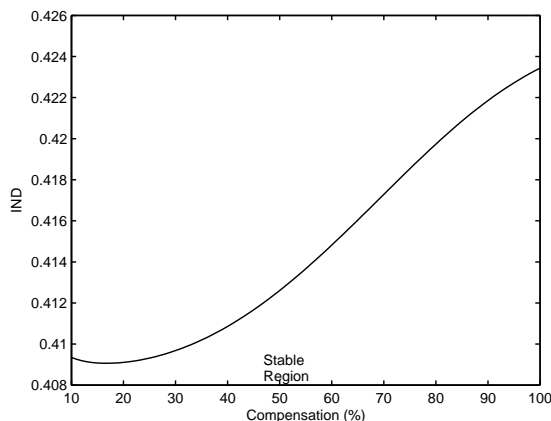

**Figure 5:** IND values at second iteration.

## 5 Conclusions

In this paper an integrated optimal FACTS allocation, which includes both static and dynamic constraints has been proposed. This framework allows an interactive selection of optimal series compensation taking into account small signal stability properties. The proposed method consists of two sequential and interactive stages: (i) allocation procedure in order to assess the optimal series compensation allocation in the network and (ii) selection of series compensation degree that keeps the system stable in a small signal stability point of view. The objective function is the increase in the transmission system capability using a minimum number of FACTS and their investments. By the numerical application carried out in the sequence, one can summarize that the proposed framework is capable of providing optimal FACTS allocations which are not only economically but also technically feasible. Besides, the framework itself is simple and can be easily implemented

interfacing optimal power flow and small signal stability programs, enabling system planners to improve transmission systems loadability and to recognize risky dynamical behavior in the system at once. Another advantage of the present approach is its flexibility in setting how far from its small signal stability margins the system must operate. For instance, in the specific case previously studied, it was just required that the system worked in a stable manner ( $\min(IND) > 0$ ), what can be easily adjusted according to a specific operation policy. In this work the considered dynamical issue was SSR. However, the same basic idea can be extended to larger power systems and interarea modes tracked along the optimization process. All these considerations show the validity and feasibility of the proposed framework.

## Acknowledgments

The authors would like to thank the support of the Brazilian institutions CAPES, CNPQ and FAPEMIG.

## REFERENCES

- [1] F. Allella, and D. Lauria, "A fast optimal dispatch with global transient stability Constraint", *IEE Proceedings - Generation, Transmission and Distribution*, Vol. 148 No. 5, pp. 471-6, 2001.
- [2] F. Allella, E. Chiodo and D. Lauria, "Probabilistic approach to series compensation design", *The International Journal for Computation and Mathematics in Electrical and Electronic Engineering* Vol. 22 No. 2, 2003 pp. 372-387.
- [3] J. W. Marangon Lima, E. J. Oliveira, K. C. Almeida, "Allocation of FACTS Devices in Hydrothermal Systems". *IEEE Transactions on Power Systems*. Nova York: , v.15, n.1, pp.276 - 282, 2000.
- [4] S. Gerbex, R. Cherkaoui, and J. Germond, "Optimal location of multi-type FACTS devices in a power system by means of genetic algorithms", *IEEE Trans. Power Syst.*, vol. 16, pp. 537-544,
- [5] C. Lehmker, "Economical Operation of FACTS-Devices in Liberalized Energy markets", *IEEE Transactions on Power Delivery*, vol. 17, no. 2, April 2002.
- [6] R. Rajaraman, F. Alvarado, A. Maniaci, R. Camfield, S. Jalali, "Determination of location and amount of series compensation to increase power transfer capability", *IEEE Trans. Power Syst.* 13 (2) (1998) 294299.

- [7] Canizares CA. et al. "Using FACTS controllers to maximize available transfer capability". *Bulk power systems and dynamics*, part IV, restructuring; 1998.
- [8] F. G. Lima, F. D. Galiana I. Kockar and J. Munoz, "Phase shifter placement in large-scale systems via mixed integer linear programming", *IEEE Transactions on Power Systems*. Nova York: , v.18, n.3, pp.1029-1034, 2003.
- [9] S.N. Singh, A.K. David, "Optimal location of FACTS devices for congestion management", *Electric Power Systems Research* Vol. 58, (2001) pp. 7179.
- [10] P. Preedavichit, S.C. Srivastava , "Optimal reactive power dispatch considering FACTS devices", *Electric Power Systems Research* Vol. 46 (1998) pp. 251257
- [11] J. Griffin, D. Atanackovic, F.D. Galiana, "A study of the Impact of FACTS on the Secure-economic Operation of Power Systems", *12th Power Systems Computation Conference*, pp.1077-1082, Dresden, August 19-23, 1996.
- [12] S.N. Singh, "Location of FACTS devices for enhancing power system's security", *Conference on Large Engineering Systems Power Engineering (LESCOPE 01)*, 2001, pp. 162166.
- [13] S.-H. Song, J.-U. Limb, S.-I. Moon, "Installation and operation of FACTS devices for enhancing steady-state security", *Electric Power Systems Research* vol. 70, pp. 7-15, June, 2004.
- [14] M. Noroozian, L. Angquist, M. Ghandhari, G. Anderson, "Improving power system dynamics by series-connected FACTS devices", *IEEE Trans. Power Deliv.* Vol. 12 No. (4), (1997), pp. 1635-1641.
- [15] Y. Tang, A.P.S. Meliopoulos, "Power system small signal stability analysis with FACTS elements", *IEEE Trans. Power Deliv.*, Vol. no. 12 (3) (1997) pp. 13521361.
- [16] G. Wu, A. Yokoyama, J. He, Y. Yu, "Allocation and control of FACTS devices for steady-state stability enhancement of largescale power system", *Proceedings of IEEE International Conference on Power System Technology*, vol. 1, 1998, pp. 357361.
- [17] A. Del Rosso, C. A. Caizares, and V. Doa, "A Study of TCSC Controller Design for Power System Stability Improvement", *IEEE Transactions on Power Systems*, Vol. 18, No. 4, November 2003, pp. 1487-1496.
- [18] N. Yorino, E. E. El-Araby, H. Sasaki, and S. Harada, "A New Formulation for FACTS Allocation for Security Enhancement Against Voltage Collapse", *IEEE Transactions on Power Systems*. Nova York: , v.18, n.1, pp.3-10, 2003.
- [19] C. Canizares , Z. Faur "Analysis of SVC and TCSC controllers in voltage collapse". *IEEE Trans Power Syst* 1999;14(1):18.
- [20] P. Kundur. "Power System Stability and Control", *McGraw-Hill*, 1994.
- [21] P.M. Anderson, B.L. Agrawal, J.E. Van Ness. "Subsynchronous Resonance in Power Systems", *Ed. IEEE Press*, 1988.
- [22] N. Balabanian, and T. Bickart, "Linear Network Theory", *Matrix Publishers, Inc.*, Beaverton, Oregon, 1981, pp. 118-132.
- [23] C.M. Ong. "Dynamic Simulation of Electric Machinery", *Prentice Hall PTR*, 1998.
- [24] F. Verhulst. "Nonlinear Differential Equations and Dynamical Systems", *Springer-Verlag Berlin Heidelberg*, 1990.
- [25] M. Tomin, B. I. L. Lopes, R. C. Leme, R. Jovita, A. C. Zamboni de Souza , P. P. C. Mendes, J. W. Marangon Lima, "Proposal of a Hopf Bifurcation Index for Power Systems Stability Assessment", *Submitted for publication in IEE Proceedings on Generation, Transmission and Distribution*, 2005.
- [26] J. M. Campagnolo, N. Martins, D. M. Falco. "Refactored Bi-Iteration: A High Performance Eigensolution Method for Large Power System Matrices". *IEEE Transactions on Power Systems*, Vol. 11, No. 3, pp. 1228-1235, August 1996.
- [27] IEEE SSR WORKING GROUP. "Terms, Definitions and Symbols for Subsynchronous Oscillations". *IEEE Transactions on Power Apparatus and Systems*, vol. PAS-104, No. 6, June 1985.
- [28] A. J. Wodd,; B. Wollenber, "Power Generation, Operation and Control. 2nd ed. New York: Wiley, 1996.