

MICROGRIDS BLACK START AND ISLANDED OPERATION

J. A. Peças Lopes, C. L. Moreira, F. O. Resende
INESC Porto – Instituto de Engenharia de Sistemas e Computadores do Porto and
FEUP – Faculdade de Engenharia da Universidade do Porto
Rua Dr. Roberto Frias 378, 4200-465 Porto, Portugal
jpl@fe.up.pt

Abstract – A low voltage distribution network with large amounts of small sized dispersed generation can be operated as an isolated system in certain conditions. This paper presents the control strategies to be used in such a system to deal with islanded operation and to exploit the local generation resources as a way to help in power system restoration after a general blackout. A sequence of actions for the black start procedure is identified and it is expected to be an advantage for power system operation in terms of reliability as a result from the presence of a very large amount of dispersed generation.

Keywords: *microgrids, power system restoration, microgenerators, energy storage, islanded operation*

1 INTRODUCTION

Following the increasing penetration of Dispersed Generation (DG) in Medium Voltage (MV) networks, the connection of microgeneration to Low Voltage (LV) grids starts attracting attention due to its potential for reducing greenhouse gas emissions, increasing reliability to final consumers and positive impacts it may carry to global system operation, planning and expansion. In this context, a new concept – the MicroGrid (MG) – is under development. A MG corresponds to a LV electrical grid where electrical loads and small generation systems (fuel cells, microturbines, wind generators, photovoltaic panels) together with storage devices (like flywheels and batteries) coexist through an embedded management and control system [3].

If a general or local blackout occurs, local generation capabilities in the LV grid can be exploited to reduce customer interruption times by: a) providing a fast black start recovery in the LV grid; b) allowing MG islanded operation to feed local consumers until the MV network becomes available.

Conventional power system restoration is a very complicated process, usually involving tasks carried out manually according to predefined guidelines [1]. They have to be completed in a fast way, in a real-time basis and under extreme stressed conditions. The complexity of this process makes decision support tools extremely valuable to assist system operators [2].

In a MG the whole restoration procedure is much simpler because of the reduced number of controllable variables (loads, switches and microsources). On the other hand, most of the microsources (MS) are not suitable for a direct connection to the LV grid due to the characteristics of the electric power produced in such units. Usually a DC/AC or AC/DC/AC power electronic

interface is required. Furthermore, it is not expected to have fully controllable synchronous generators directly connected to the LV grid, which will be liable for controlling system frequency and voltage (balance of load and generation). A scenario with the absence of controllable synchronous in a MG demands some of the MS inverters to be capable of emulating a synchronous machine operation in order to allow running into islanded mode in parallel with other MS. These units play a key role in the restoration process, as discussed in this paper. MS specificities (like primary source response time constants, intermittency of renewable energy sources, technical limits), the control characteristics of the power electronic interfaces and its thermal limitations lead to the identification of very specific restoration sequences.

After understanding the interaction among MS and local controllable loads, it is possible to define a totally automatic procedure for MG restoration, since a central control and a communication infrastructure are available. Under the MG concept such approach is possible due to specific control architecture and to the possibility of establishing communication among different types of controllers spread over the LV network.

In this paper an identification of a sequence of actions to be carried out during the MicroGrid Black Start (BS) is presented and discussed. Two inverter control techniques are described and combined to find a suitable approach for LV distribution system restoration and ensure its stable operation. In order to identify the restoration sequences two simulation platforms were developed and exploited when dealing with a LV study case network: an *EMTP-RV*® tool used to analyse initial fast transients and a *MatLab*® *Simulink*® simulation platform used to evaluate the longer term dynamic behaviour of the islanded MG.

2 MICROGRID ARCHITECTURE

As mentioned before, a MG involves a LV electrical grid, loads (some of them interruptible), controlled and uncontrolled MS, storage devices and a hierarchical-type management and control scheme supported by a communication system [3]. Such concept has been developed within the framework of the EU R&D MicroGrids project [3].

In this architecture the MG is controlled and managed by a MicroGrid Central Controller (MGCC) installed at the MV/LV substation. The MGCC possesses several key functions (such as load forecasting, demand

side management, economic scheduling of microgenerators, security assessment, etc.) and heads the hierarchical control system. In a second hierarchical control level, controllers located at loads or groups of loads (LC) and controllers located at the microsources (MC) exchange information with the MGCC and control local devices.

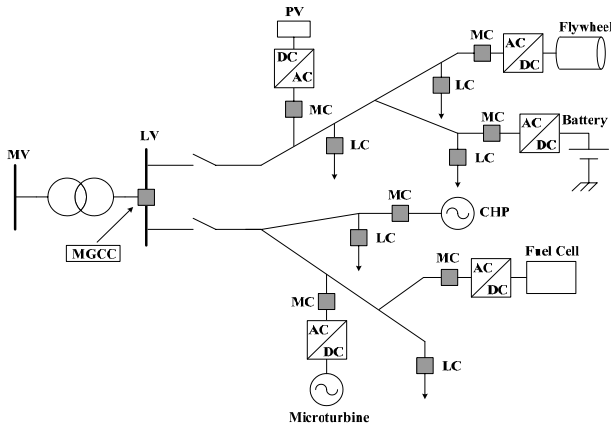

Figure 1: Microgrid with several microsources, loads, control and management equipment

The whole system operation requires communication and interaction between two sets of devices: LC on one hand, as interfaces to control loads through the application of an interruptability concept, and on the other hand MC controlling microgeneration active and reactive power production levels. The MGCC, as central controller, promotes adequate technical and economical management policies and provides set-points to LC and MC. In the approach described in this paper, the MGCC is also responsible for local BS functionalities. The BS procedure identified in advance, together with system technical limitations, will be embedded in the MGCC as a software module.

It is important to understand that the amount of data to be exchanged among the several network controllers is small, as it includes mainly set-points to LC and MC, information about the active and reactive powers and voltage levels or messages to control the LV system restoration. At the same time, the MG covers a small geographical area. These factors contribute to ease the establishment of the required communication system.

3 DYNAMIC MODELS

This section provides a brief explanation on the dynamic models adopted for MS and power electronic interfaces used in the simulation tools.

3.1 Microsource Modelling

Several MS technologies were considered to coexist in the MG and the corresponding dynamic models were derived. A detailed description of the models adopted for solid oxide fuel cells (SOFC) and single shaft microturbines (SSMT) can be found in [4]. A small asynchronous wind generator (fixed speed) directly connected to the LV grid was also included in the simulation platforms. Details of the maximum power tracking control

system were not included in the PV model. Instead, it was assumed that the array is always working at its maximum power level for a given temperature and irradiance as described in [5].

Storage devices like flywheels and batteries are modelled as constant DC voltage sources (taking into account the time span under analysis) coupled with static converters to be connected to the LV electrical network. Usually its active power is injected into the MG proportionally to the frequency deviation [6].

3.2 Inverter Modelling

Several MS, such as SSMT, SOFC and PV are not suitable for supplying power directly to the grid, since either this electricity generation is in DC form or it is generated as AC at high frequencies. Inverters are then needed to provide AC grid interface. Inverter control strategies are crucial for an adequate MG operation. Inverter controls can be divided into two types [7]: a) PQ inverter control; b) Voltage Source Inverter (VSI) control logic.

It is important to mention that when analysing the dynamic behaviour of the MG, inverters detailed modelling is usually avoided. Inverters long term dynamic models are represented by their control functions. This means that fast transients related with commutation of the solid state switches are not considered, assuming, in this way, that power is injected at the AC side without harmonics, distortions, losses or delays. If a transient analysis is required this approach demands instead a full representation of the inverter.

1) PQ Inverter Control

A PQ inverter control corresponds to a combined control of both inverter and primary energy source, when this becomes physically possible. This means that the inverter only injects into the grid the power available at its input. An example of the application of a PQ control stays in a PV unit. The reactive power injected corresponds to a pre-specified value defined locally or from the MGCC. The PQ control of an inverter can be performed using a current control technique: the inverter current is controlled in amplitude and phase to meet the desired set-points of active and reactive power [8].

2) Voltage Source Inverter Control

In this case the inverter is controlled to feed the load with pre-defined values for voltage and frequency according to a specific control strategy. The control principle of a VSI to be installed in a MG should emulate the behaviour of a synchronous machine. There is thus a possibility to control voltage and frequency on the AC system by means of inverter control.

Considering such a VSI operating in parallel with an AC system with angular frequency ω_{grid} , the active output power of the VSI is automatically defined by the well known frequency droop characteristic, as depicted in Figure 2.

Dispatching the inverter output power can be achieved by means of a convenient modification on the idle frequency (ω_{01} , ω_{02}). If the main AC system is lost,

the output power of each inverter is adjusted according the droop settings and the network frequency drifts towards a new value. The active power is shared among the inverters at the new frequency value according to these droop characteristics. Frequency variations provide an adequate way to define power sharing among several VSI operating in parallel in an islanded grid [9]. Similar considerations can be made in what concerns the voltage/reactive power control, using also a voltage droop concept [11]. A three-phase balanced model of a VSI implementing these two droop concepts was derived from a single-phase version presented in [10] and is shown in Figure 4.

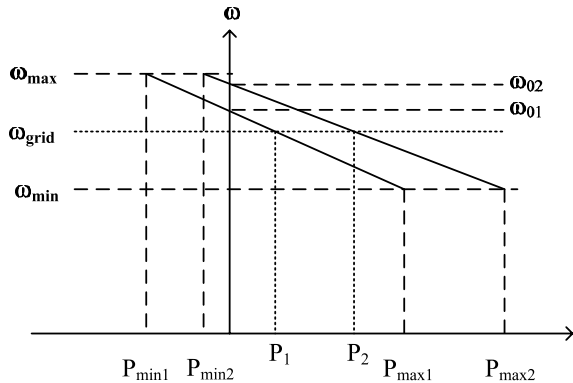

Figure 2: Active power versus frequency droops

The VSI terminal voltage and current are measured to compute active and reactive power levels. This measuring stage introduces a delay that corresponds to a decoupling, performed through the “Decoupling” transfer functions shown in Figure 4. The active power determines the frequency of the output voltage by the active power/frequency droop (K_f). Similarly, the reactive power determines the magnitude of the output voltage by the reactive power droop (K_v). A phase feed-forward control was included for stability purposes [10], corresponding to the K_{ff} loop in Figure 4.

4 CONTROL STRATEGIES FOR MICROGRIDS OPERATION

If there are no synchronous machines to balance demand and supply, inverters should be responsible for controlling frequency during islanded operation. A

voltage regulation strategy is also required; otherwise the MG could experience voltage and/or reactive power oscillations [9, 12].

If a cluster of MS is operated within a MG and the main power supply (the MV network) is available, all the inverters can be operated in the PQ mode, because a voltage and frequency reference is available. However if the MV network is lost all the inverters will shut down because there will not be a voltage reference within the MG and it will not be possible to obtain an exact balance between load and generation. This means that a general frequency control strategy should be followed in order to operate the MG in islanded mode. Two main strategies are possible:

- Single Master Operation (SMO): A VSI is used to provide the reference voltage when the main power supply is lost;
- Multi Master Operation (MMO): Two or more inverters are operated as VSI;

The presence of a VSI unit is crucial in order to provide a voltage and frequency reference during the emergency mode. A VSI has the ability to react to power system disturbances (for example, load-following or wind fluctuations) based only on information that is available locally at the inverter – voltage and current measurements [11]. Such a VSI should be coupled with a storage device with a limited capacity in order to be able to compensate natural load and production variations. This is an important issue for a successful BS and islanded operation.

4.1 Single Master Operation

In a SMO mode, most of the MS are connected to the network through inverters with a PQ control type and a single VSI inverter associated with an energy storage device – the master – that provides the frequency reference, as depicted in Figure 3.

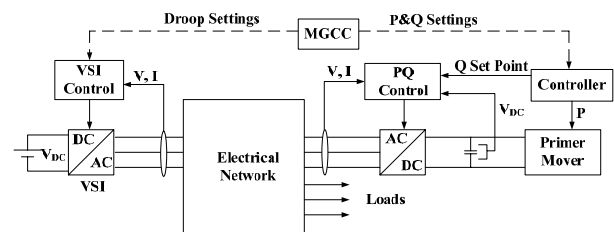

Figure 3: SMO architecture

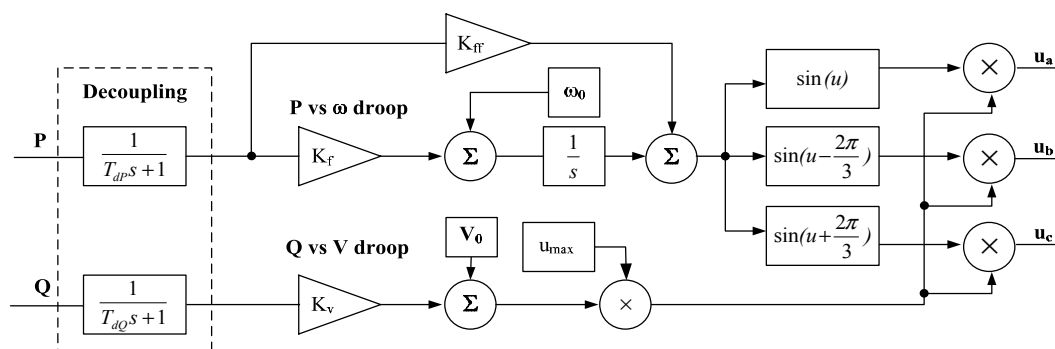

Figure 4: VSI three phase control model

Such VSI should be responsible for fast load-tracking. If necessary droop settings of the VSI can be changed from the MGCC according to the operating conditions and in order to avoid large frequency excursions. In this case, PQ controlled MS can receive from the MGCC setting points or can adopt a local PI frequency control, defining target values for active output powers of its primary energy sources.

Assuring a zero frequency deviation during any islanded operating condition should be considered as a key issue for any control strategy. As a matter of fact such procedure is needed to avoid storage units to inject (or absorb) active power whenever the MG frequency deviation is different from zero.

4.2 Multi Master Operation

In a multi master approach, there are several inverters operating as VSI with a pre-defined frequency/active power and voltage/reactive power droop. Other PQ controlled inverters may also coexist.

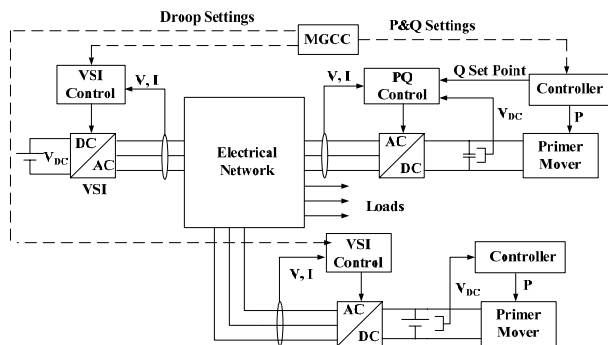

Figure 5: MMO architecture

Correction of MG frequency deviations can be performed by changing the idle frequency value (defined in Figure 2), as used in proportional integral frequency governors of synchronous generators. Change of the idle frequency can instead be performed centrally by the MGCC, as a kind of centralized secondary control, using the communications infrastructure. In this control strategy the issue of obtaining a zero frequency deviation is also a driving concern, as in the SMO approach and for the same reasons.

5 MICROGRID BLACK START

The MG black start involves a sequence of control actions, defined through a set of rules and conditions to be checked during the restoration stage. These rules are identified in advance and embedded in MGCC software.

5.1 General Assumptions

The success of a MG restoration procedure requires availability of some MS with BS capability, which involves an autonomous local power supply to feed local auxiliary control systems and to launch generation. However the MS restart procedure is not dealt in the work presented in this paper. The implementation of BS functionalities in a MG with an architecture as the one described before, is possible since there is also availability for:

- Bidirectional communication between the MGCC and local controllers (MC and LC);
- Updated information, obtained before disturbance, about the status of load/generation in the MG and about availability of MS to restart.
- Automatic load disconnection after system collapse to avoid large frequency excursions and MS overload during the initial stages of the restoration procedure;
- Capability to disconnect the MV/LV Distribution Transformer (DT) from the MV network, before starting the BS procedure;
- Capability for LV network area separation.

The BS procedure was developed assuming that MS with BS capability (SSMT and SOFC) have storage devices (batteries or supercapacitors) in the DC bus of their inverters and the MG adopts, at least during the first stages of this sequence, a multi master control approach. In order to operate in a MMO mode these inverters operate as VSI.

During normal operation the MGCC periodically receives information from LC and MC about consumption levels and electric production and stores this information in a database. It also has information about the technical characteristics of the different MS, like active and reactive power limits.

5.2 Sequence of Actions for MG Black Start

After a system blackout, the MGCC will try to restore the last MG load scenario. The main problems to deal with during the restoration procedure include building the LV network, connecting microgenerators, controlling voltage, controlling frequency and connecting controllable loads. Considering these problems the following sequence of actions for MG restoration should be carried out:

- Disconnection of all loads in order to avoid large frequency and voltage deviations when energizing the network. The MG should also be sectionalized around each MS with standalone restart capabilities in order to allow it to feed its own (protected) loads. These actions lead to the creation of small islands inside the MG to be synchronized later.
- Building the LV network. The MGCC decides which MS energizes the LV cables and the DT based on information about rated powers, load percentage or other market conditions. In order to comply with the LV grid earthing safety procedures [13] when building the LV network, it is necessary to energize the DT as soon as possible, since the earth connection is performed at the DT neutral point and it is restored only after DT energization. When energizing the transformer by the LV side, a large inrush current is experienced, and cannot be supported by the electronic components of the inverters. To overcome this problem, transformer energization should be performed using a ramp-wise voltage generated by the inverter of the MS selected for this task.
- Small islands synchronization. MS already in operation in standalone mode should be synchronized

with the LV network. The synchronization conditions (phase sequence, frequency and voltage differences) should be verified by local MC in order to avoid large transient currents and power exchanges. If there are controllable MS without BS capability, they can then also be synchronized with the LV to supply their local controls and prepare to launch generation.

- Connection of controllable loads to the LV network is performed if the MS running in the LV network are not at fully loaded. The amount of power to be connected should take into account the available storage capacity in order to avoid large frequency and voltage deviations during load connection.
- Connection of non-controllable MS, like PV and wind generators. At this stage the system has MS and loads capable of smoothing voltage and frequency variations due to power fluctuations in non-controllable MS, so they can now be connected.
- Load increase. In order to feed as much load as possible, depending on production capability, other loads can then be connected.
- MG synchronization with the MV network when it becomes available. The synchronization conditions should be verified again. Before a general blackout two situations can occur: the MG is importing power or the MG is exporting power to the MV network. If the MG was importing power, it will not be possible to connect all the local loads. In this case, remaining unsupplied load can then be restored.

6 SIMULATION PLATFORMS

Two simulation platforms were implemented under *EMTP-RV*® and *MatLab*® *Simulink*® environments in order to evaluate the transient and dynamic behaviour of several MS and the corresponding power electronic interfaces during the BS sequence. To analyse, in a more detailed way, the initial behaviour of the MG restoration process, the *EMTP-RV*® platform was used. This required implementing the MS models and their controls to these simulation platforms.

At this stage of the carried research only three-phase balanced operation of the MG was considered.

A study case LV network was defined by NTUA within the MicroGrids project [3] and was used in this research. This network is shown in Figure 6. The simulation platform developed under *EMTP-RV*® is presented in Figure 7. A similar platform was also developed under *MatLab*® *Simulink*®. Because of space limitations this simulation platform is not presented in the paper.

7 RESULTS

For this LV test system it was assumed that a general collapse took place and was followed by: a) the disconnection from the MV grid of the MV/LV transformer; b) the disconnection of the loads and c) the automatic

creation of islands operating in standalone mode with the SSMT and the SOFC. The sequence of actions defined for MG black start, described in section 5, was tested in the simulation platforms and analysed through the results obtained. Network behaviour during BS initial stages was evaluated with the *EMTP-RV*® platform, including in this case the inverter commutation details. The general dynamic behaviour of the MG was analysed using the *MatLab*® *Simulink*® platform.

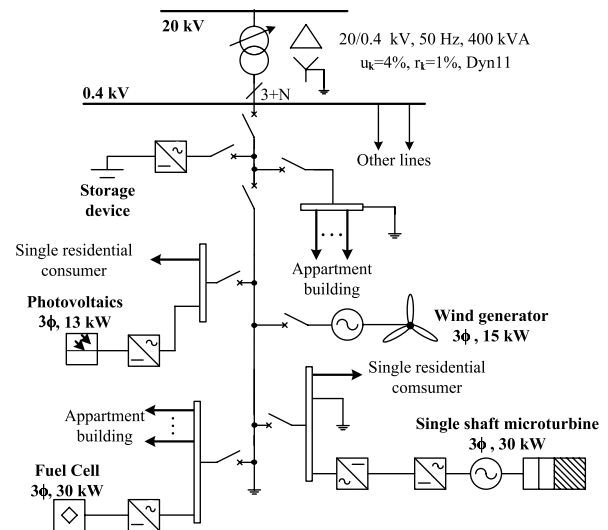

Figure 6: Study case LV network.

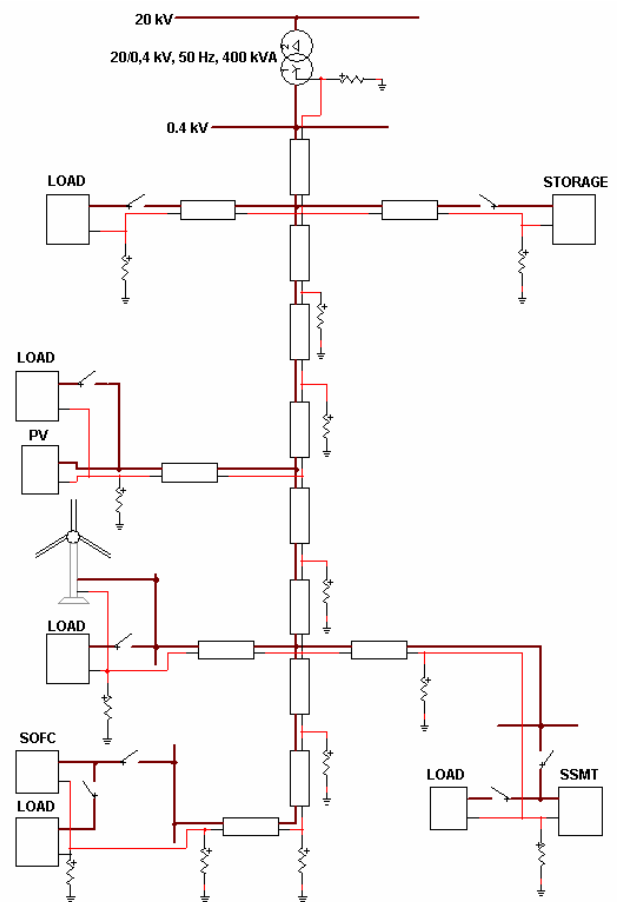

Figure 7: Study case LV network in *EMTP-RV*® platform.

As the other MS are assumed to be feeding their protected loads, the storage device shown in Figure 6 was selected for energizing the LV network and the DT at $t=0.5s$, using a voltage ramping control in this inverter, through 0.5 seconds. The obtained inverter current is presented in Figure 8 and it can be observed that the DT magnetizing current was kept in low values.

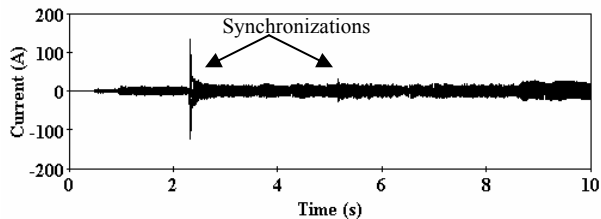

Figure 8: Storage inverter current during the initial BS stage

As mentioned previously, after energizing the DT and building the LV network, the next step of the MG black start procedure is the synchronization of both SOFC and SSMT operating in standalone mode and feeding their protected loads. To check the synchronization conditions the MGCC sends instructions to the VSI inverters (initially to the SOFC and later to the SSMT) to produce a small frequency change, as it can be seen in Figure 9 (at $t=1.8s$ and $t=4.5s$). After synchronizing the SOFC and SSMT it is possible to connect some controllable loads and non-controllable MS. Figures 9 and 10 show the impact of these control actions in the VSI frequencies and MS active power outputs, with SOFC and SSMT being synchronized at $t=2.3s$ and $t=4.6s$ respectively. The impact in the storage inverter current resulting from these synchronizations can also be observed in Figure 8.

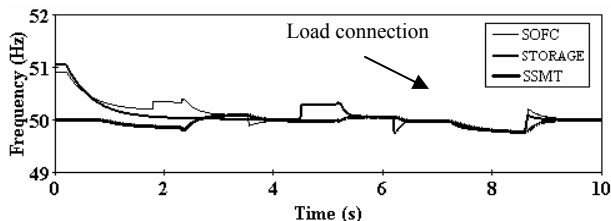

Figure 9: Frequency in each VSI.

It can be observed in Figure 10 that active powers present some small oscillations. These oscillations are the result of VSI filter interactions and occur in the absence of active damping of the loop formed by the filter capacitors and the tie-line inductance [11]. These oscillations are not uncommon in power systems and can be damped by the inverters, given sufficient inverter bandwidth [11].

In order to get an extended overview of the BS sequence, the MG *MatLab® Simulink®* platform was used. The results obtained for VSI frequencies, active and reactive power outputs and bus voltages are described in next figures. In this case, in less than 1/3 of EMTP simulation time it is possible to get these results.

Load reconnection is a critical issue in this procedure because of frequency deviation it induces, requiring therefore a special attention. If a frequency deviation

remains for some time a local secondary control is used. Voltage and reactive power control can be easily performed by adjusting the droop settings of each VSI or the reactive set-point of PQ inverters.

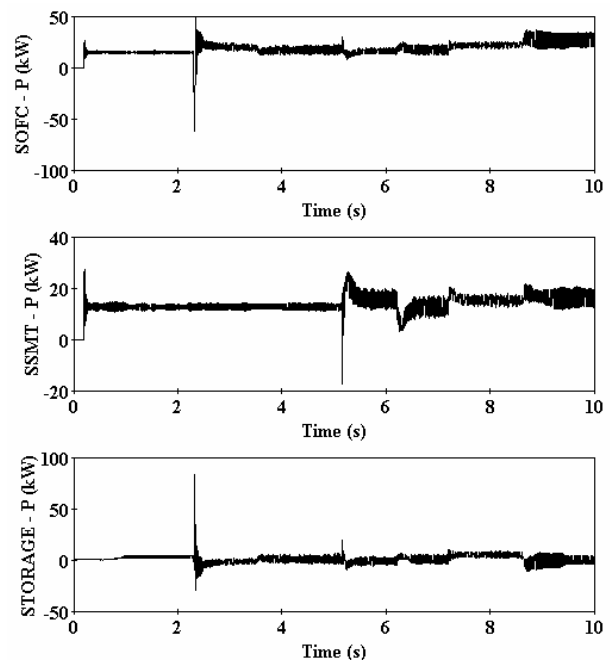

Figure 10: Active power in each VSI.

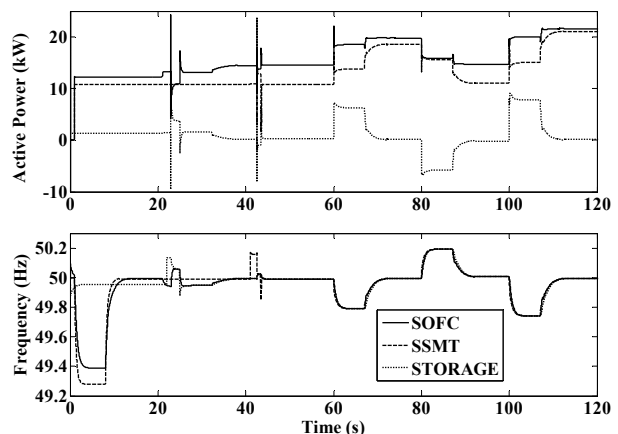

Figure 11: Active power and frequency at each VSI

During the BS procedure, voltage regulation through droops ensures MG stability and no reactive power oscillations among the MS are observed (Figure 12). Contrary to what happens with active power sharing (which is defined through droops), the reactive power sharing is greatly influenced by the voltage drops at each specific node where reactive loads are connected (due to LV cable impedances).

When the MV network becomes available, the MGCC requires all the VSI to change frequency and voltage, to check synchronization conditions, by slightly and equally changing their idle frequencies and voltages. This procedure guarantees that no significant changes in MS power output occur. After synchronizing the MG with the MV network, VSI idle frequency and

voltages are restored to the values they had before in order to maintain the power dispatch in the MG.

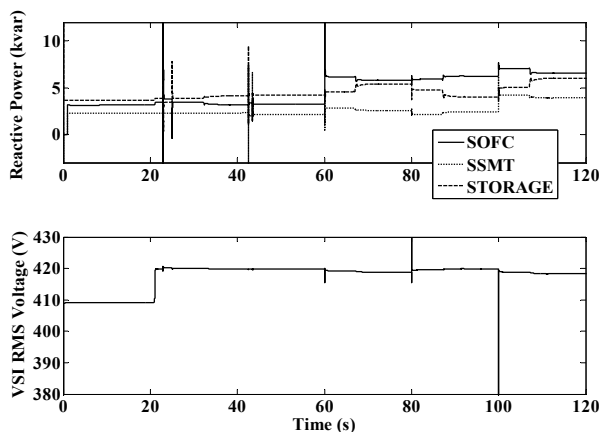

Figure 12: Reactive power in each VSI and storage device terminal voltage

By comparing the active power outputs of the SSMT and SOFC after a load increase, described in Figures 11 and 13, it is possible to observe that the response of their primary sources is delayed (according to their physical characteristics) relatively to the corresponding VSI active power outputs. This happens because of the almost instantaneous initial contribution provided by the storage devices assumed to be installed in their DC links.

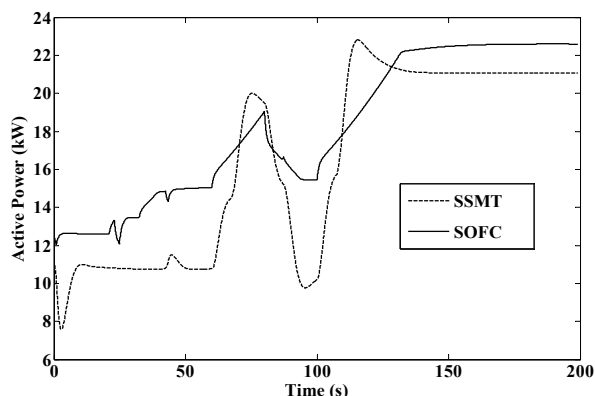

Figure 13: Active power in the primary energy source (SSMT and SOFC)

8 CONCLUSIONS

This paper described the set of control strategies needed for islanded and black start operation of MicroGrids where no directly grid connected synchronous generation machines are used. From the results obtained it was observed that storage devices play a key role for the success of system islanding and restoration.

The identification of a set of rules and conditions to be checked during the restoration stage by the Microgrid components was derived and evaluated through numerical simulation, proving the feasibility of such procedures. Such a successful verification constitutes a significant contribution and shows that microgeneration resources should be exploited further.

ACKNOWLEDGMENTS

The authors want to express their thanks to the research team of the MicroGrids project for valuable discussions that helped developing this research and to the EU for funding the project.

REFERENCES

- [1] J. J. Ancona, "A Framework for Power System Restoration Following a Major power Failure", IEEE Transactions on Power Systems, vol. 10, pp 1480-1485, 1995.
- [2] M. M. Adibi, R. J. Kafka, D. P. Milanicz, "Expert System Restoration", IEEE Transactions on Power Systems, vol. 9, pp 1592-1600, 1994.
- [3] J. A. Peças Lopes et al., "Management of Microgrids", JIEEC2003, Bilbao, 28-29 October 2003.
- [4] Y. Zhu, K. Tomsovic, "Development of Models for Analyzing Load-Following Performance of Microturbines and Fuel Cells", Electric Power Systems Research vol. 62, pp 1-11, 2002.
- [5] N. Hatziaegyriou et al, "Modelling of Microsources for Security Studies", Proceedings of the CIGRÉ 2004 Conference, Paris, France, August 30–September 3, 2004.
- [6] G. Kariniotakis, et al, "DA1 – Digital Models for Microsources", MicroGrids project Deliverable DA1, 2003.
- [7] S. Barsali, M. Ceraolo, P. Pelacchi, D. Poli, "Control Techniques of Dispersed Generators to Improve the Continuity of Electricity Supply", Trans. of PES Winter Meeting 2002, IEEE, vol. 2, pp 789-794, 27-31 Jan. 2002.
- [8] H. Akagi, Y. Kanazawa, A. Nabae, "Instantaneous Reactive Power Compensators Comprising Switching Devices without Energy Storage Components", IEEE Transactions on Industry Applications, vol. IA-20, No. 3, pp 625-630, May/June 1984.
- [9] R. H. Lasseter, P. Piagi "Providing Premium Power through Distributed Resources", Proceedings of the 33 rd Hawaii International Conference on System Sciences, vol. 4, Maui, Hawaii, 4-7 Jan 2000.
- [10] A. Engler "Regelung von Batteriestromrichtern in Modularen und Erweiterbaren Inselnetzen", Dissertation.de, Berlin, May 2002, ISBN 3-89825-439-9.
- [11] M. C. Chandorkar, D. M. Divan, R. Adapa, "Control of Parallel Connected Inverters in Standalone AC Supply Systems", IEEE Transactions in Industry Applications, vol. 29, No. 1, January/February 1993.
- [12] R. H. Lasseter, P. Piagi, "Microgrid: A Conceptual Solution", Proceedings of the 35th PESC, pp. 4285-4290, Aachen, Germany, June 2004.
- [13] N. Jayawarna, M. Lorentzou, S. Papathanassiou, "Review of Earthing in a Microgrid", DRAFT Issue No 1, MicroGrids project Deliverable of WP E, 2004.