

# ASSESSMENT OF A SUB-TRANSMISSION AND DISTRIBUTION SYSTEM UNDER COORDINATED SECONDARY VOLTAGE CONTROL

Flávio A. B. Lemos\*    Wilson L. Feijó Jr  
IEEE Member

Lemos@ee.pucrs.br    feijo@ee.pucrs.br  
Electrical Energy System Group  
Dept. of Electrical Engineering - PUCRS  
Av. Ipiranga 6681, B.30, Room 215  
90619-900- Porto Alegre, RS, Brazil.

Luis C. Werberich

werberich@ceee.com.br  
Companhia Estadual de E. Elétrica  
Department of Engineering,  
Av. Ipiranga 8300, E2, Block C,  
91530-000-Porto Alegre, RS, Brazil

Mauro A. da Rosa

magusto@rge-rs.com.br  
RGE - Rio Grande Energia S.A.  
Department of Engineering,  
Rua São Luis 77, Santana,  
90620-170-Porto Alegre, RS, Brazil

**Abstract - The present operation practice of power systems consists in the maximization of loading of the existing generation, transmission and distribution systems capacities. The increasing demand for energy with reliability, performance index and power quality, together with a desire to an optimized operation modes in normal and emergency conditions, are the targets of modern power systems. The aim of this paper is to present the dynamic simulations and analysis focused on Under Load Tap Changing (ULTC) coordination and their effects on power losses, reactive flow and voltage profiles, which are part of Coordinated Secondary Voltage Control (CSVC) proposed. Performance results of control scheme proposed to normal operation conditions for incremental load increasing and decreasing (light to medium and medium to heavy load levels) are presented. Two emergency conditions are simulated: transmission line outage and feeders outage.**

**Keywords:** *Secondary Voltage Control, Coordinated Voltage Control, ULTC Coordination, Voltage Regulation*

## 1 INTRODUCTION

Over the last years, power systems planning and operation conditions have been improving in terms of system complexity and regulatory issues. In addition, problems related with distribution systems have not been given much concern if compared with transmission systems. However, the increasing demand for energy with quality, safety and reliability is the main objective of modern distribution systems. Otherwise, electricity utilities must be well remunerated for their services, and real time operation of distribution grid must be optimized for both normal and emergency conditions. In order to achieve these conditions, the automation of power systems operation is essential and requires special methods and computational tools.

Aiming to provide the conditions described above, the implementation of a control centre to manage the system in real time conditions (which is called Distribution Management Systems - DMS), is needed. In this system is desirable a function for voltage and reactive power control (Volt - VAr Control) in real time, which deals with a variation of operational conditions resulting from changes in power demands, load characteristics, network configurations and operation

constrains, providing significant benefits for normal and emergency conditions over traditional implementations [1, 2, 3]. The use of principles of secondary voltage control, together with the Volt/VAr coordinated control support to provide an effective control for several conditions of large demand variations and operational conditions. Both methodologies have been increasing in interest in the last years due to operating systems in stressed conditions.

Some papers present the secondary voltage control problem and demonstrate experiences, hierarchical philosophy and control schemes for European systems, such as France [4, 5], Italy [6, 7], Belgium [8] and Spain [9]. Preliminary results related to the prospective application of the secondary voltage control to parts of Brazilian system are presented in [10].

Studies dealing with functions for Distribution Automation and Distribution Management Systems and centralized Volt/VAr control have been published recently [11]. A Paper describing Distribution Management Systems and practical aspects of distribution automation is presented in [12]. In [13] the tools and techniques of the real DMS environment are presented. A DMS application is described and detailed in terms of a distributed multi-task client server architecture in [14]. Some papers describe algorithms for centralized Volt/VAr control [15, 16]. In [17] is described a Volt/VAr control project in which a centralized control was implemented to manage a distribution system. In [18] is presented the importance of a network voltage control mechanism in a deregulated system. This is particularly important in new electrical environments, where the analysis of the cost and benefits related to the voltage service must be considered in the energy price [19].

The proposed methodology combines the idea of Secondary Voltage Control (SVC) and Voltage-Reactive Power Control (VRPC) in an integrated function called Coordinated Secondary Voltage Control (CSVC). Preliminary results of viability of CSVC using steady state approach (economic and operational aspects) in a pilot system are presented in [20] and [21].

This paper presents a dynamic analysis of a voltage control called coordinated secondary voltage control. This analysis is focused on Under Load Tap Changing (ULTC) coordination and their effects on power losses, reactive flow and voltage profiles.

Normal operations conditions considering transitions between three loading level, from light to medium and from medium to heavy, with increasing and decreasing

incremental demand, respectively, are investigated. Two emergency conditions are simulated: transmission line outage and feeder outage.

The paper is organized as follows: Section 2 shows the benefits of voltage control coordination; Section 3 describes coordination secondary voltage control scheme; the Pilot System studied is presented in Section 4; practical applications, results of simulations and conclusions are presented in sections 5 and 6, respectively.

## 2 HIERARCHICAL AND BENEFITS OF VOLTAGE CONTROL

The classic coordinated voltage control is divided in three hierarchical levels: primary, secondary and tertiary voltage controls. Below it is described how these different levels are organized.

- Primary Level: consists, basically, into unit and plant control. The first action consists in the adjustments of automatic voltage regulators installed in generators. The second one maintain the high-side voltage of step-up transformers equal to specific values, to avoid reactive power interchange among plant units. Primary actions are very fast, in a time frame of few seconds. It is considered a local control;
- Secondary Level: the main objective of this level is to adjust and to maintain the voltage profile inside a network area. Control actions in this level are carried out by VAr compensation devices like capacitors, inductors, synchronous or static voltage compensators and by ULTC. Definition and implementation of the secondary voltage control level are quite dependent on the philosophy of each utility. The time scale for secondary level is from several seconds to a minute. It is considered a regional control;
- Tertiary Level: the purpose of this level is to determine an optimal voltage profile of the network and to coordinate the secondary controllers, according to safety and economic criteria. The time frame of this control is several minutes or on demand.

The combination and coordination of several control actions may work for and provide better voltage quality. In addition, it helps to reduce overall control efforts of existing control devices, and may allow avoidance of the installation of new equipment. The main benefits of voltage control coordination can be summarized in:

- Improves voltage profile and keeps the system within line and transformer constraints,
- Increases system security with greater availability of reactive power reserves for emergency conditions,

- Reduces total power losses and reactive flow in transmission lines and transformers, through better use of reactive resources.

## 3 COORDINATED SECONDARY VOLTAGE CONTROL SCHEME

The Coordinated Secondary Voltage Control (CSVC) links the idea of SVC and VRPC in an integrated function inside a DMS, together with a strategy of reactive power global control system. This procedure requires several information to guarantee an effective solution, e.g., network topology, operational philosophy, supervisory and communication systems, characteristics of devices to be controlled, load characteristics, computational resources and analysis tools, real time algorithms, control structure, devices and priorities.

This coordinated control is divided in two levels:

- Primary level: this level consists in a local control which keeps voltages inside a specific range. Settings are calculated in off-line studies for typical operational conditions. The local controllers have common characteristics and properties like bandwidth, setting limitation and time delay. Controller time settings have to be coordinated with time delays of the other controllers in the same area to avoid voltage oscillations, which can lead the system towards voltage instability problems. The local automatic controllers affect ULTC tap positions and status of switched capacitors in order to keep some electrical variables equal to specific values provided by Remote Terminal Units (RTU). These units are based in microprocessed controllers installed in ULTC, which allow several control options and a communication link between ULTC transformers, capacitor banks and operational centers;
- Secondary level: this level is a regional control, located in the control center, and uses a set of rules in order to satisfy an optimization function, like minimise power losses and reactive flow. Another function of this level is to keep the voltage within security levels, to avoid problems with voltage instability. The computational tools to manage this control must have real time functions (e.g. state estimation) and optimization techniques to find the best combination of control settings, according to the objective function selected. The tools are integrated into SCADA, which provides real time data, like voltage measures and output signal to start secondary control actions (e.g. coordination of ULTC position and switch capacitors).

The strategy of Brazilian utilities for transmission voltage control is based in traditional approaches (mechanically switched capacitor and reactors, synchronous generator and synchronous condenser), since there is not hierarchical control (secondary and tertiary) implemented. In the same way, sub-transmission and distribution voltage control are operated using ULTC, shunt capacitor and distribution voltage regulation to support reactive power and keep voltage profiles inside operational limits. Consequently, the CSVC is a new approach to improve sub-transmission and distribution voltage control in the pilot area. The proposed scheme is depicted in Figure 1.

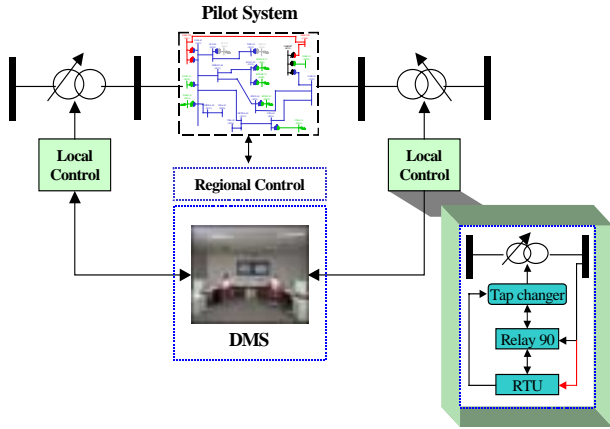

Figure 1: CSVC Scheme

The main control element used to reach the CSVC control objective is the ULTC, which is an important device for voltage control in power systems. This kind of equipment provides changes of voltage on the regulated bus and reactive power flow through the transformer.

In a restructured environment a goal for normal operation is to minimize reactive power interchange between transmission and distribution companies. This is particularly important to minimize power losses and ancillary service payments. Using ULTC to adjust previous voltage profiles obtained from CSVC scheme, it is possible maintain constant and security voltage levels in pilot buses in order to minimize power losses and reactive flows.

The main objectives of ULTC coordination must be take in account the following considerations:

- Limit voltage deviations and to keep the voltage amplitude within the pre-defined limits to assure a optimization and safe operation,
- Avoid the unnecessary changes and frequency of tap changes,
- Restraining and/or lock the operation of tap changer under special circumstance including transformer overload danger, voltage instability, etc.

The control of ULTC have some characteristics that should be take in account: slow action (slow dynamic),

discontinuous and the tap changing mechanism has a step-by-step acting.

In this paper the time adjusts for two main ULTCs, operating on automatic way, are analysed to satisfy the CSVC conditions and avoid hunting of tap changer. The methodology used for ULTCs coordination is presented in reference [22].

The general block diagram of an ULTC transformer is shown in Figure 2 [23]. In a typical control the tap position is changed discretely by the tap step, when the voltage error deviates from the specified dead band during the specified time delay. The dead band and the time delay (generally an inverse-time delay) elements are adopted to reduce the effect of transient voltage variation and avoid unnecessary tap changing operations.

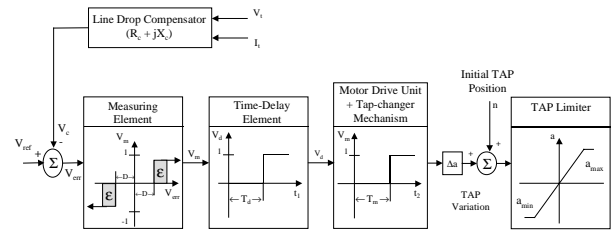

Figure 2: General block diagram of an ULTC transformer automatic control

#### 4 PILOT SYSTEM

The philosophy of Coordinated Secondary Voltage Control will be implemented in an specific area in the South of Brazil, at Rio Grande Energia (RGE) company. It is part of a research project that is being developed between RGE and Electrical Energy System Group (GSEE) of PUCRS.

Using the methodology of the Coordinated Secondary Voltage Control, the RGE system was divided in voltage control areas. The sensitivity matrices were used to choose areas and control nodes. The system is composed by 23 buses, 8 ULTC's, 5 fixed tap transformers and 7 capacitors banks. The power flow into CAX subsystem comes through two transmission lines of 230 kV. The simplified diagram of this subsystem is shown in Figure 3.

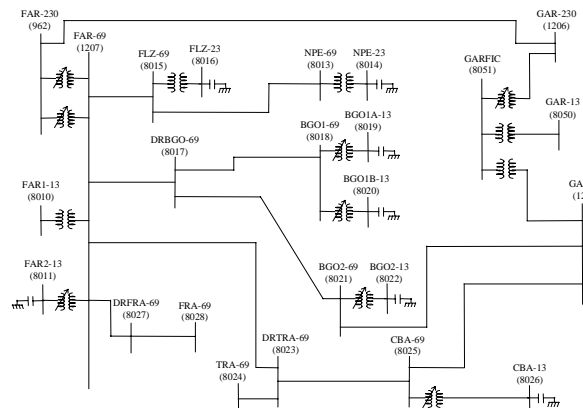

Figure 3: Pilot System

The main characteristics of the system under analysis is an high concentrate of industrial load. This kind of system is subject to load variations (large motor and diversity of industrial process) which can drive the system to present voltage oscillations and high losses since there is not reactive source close the area. The network voltage and reactive power control gives benefits in terms of quality, security and economy of the system operation. In order to achieve these objectives is need the automation degree to assure reduction of the voltage variations and provide a voltage setting to satisfy CSVC scheme. In the original system the main ULTC (FAR and GAR) are on manual operation. The economy of the network operation can be improve by the use of an automatic coordination of ULTC (Table 1), which provide a reduction of reactive power flow and losses and as consequence the CSVC keep a suitable and security voltage profile in the network.

## 5 RESULTS

### 5.1 Simulation issues

In order to realize this simulation, ULTC modelling was implemented in a software that deals with dynamic analysis. The utilized parameters are described as follow:

- dead band values were specified to enable the control act in a range of 1.0% and disable in 0.5% after the adjust,
- time delay  $T_d$ , which is the necessary time to begin tap control and to avoid unnecessary tap changing operations, was considered about 0.25 seconds,
- motor drive unit and the tap changer mechanism utilized were considered zero seconds.

The system performance is assess for incremental load increasing and decreasing (light to medium and medium to heavy load levels) and for two emergency conditions: transmission line outage and feeders outage. The emergency conditions are select from a critical set using off-line simulation (contingency analysis) and practical experience of specialists. The incremental load was applied in some steps (60 for increasing and 80 for decreasing), during a specific period of time, on all load modules inside the area. For feeders outage load was interrupted in the beginning of the simulation.

### 5.2 Steady state analysis

References [20] [21] present the preliminary steady state analysis for normal and emergency conditions and a losses analysis considering three loading levels, whose results are reproduced in Table 1.

Losses	Loading period			total	%
	heavy	medium	light		
normal (MW)	2.4	1.5	0.8	4.7	100.00
reduced (MW)	1.8	1.3	0.5	3.6	-23.40
time (hours)	8	4	12		
Economy (MW)	0.6	0.2	0.3	1.1	
Economy(MWh)	4.8	0.8	3.6	9.2	
Price MWh(sept/2001):US\$		268.24	(heavy and medium)		
	US\$	268.24	(light)		
Diary profit: US\$		2,467.76			
Month profit: US\$		74,032.94			

Table 1 – Losses Analysis for Three Loading Periods

The loading period consider the follow characteristics:

- Heavy from 09:00a.m. to 05:00p.m.;
- Medium from 05:00p.m. to 09:00p.m.;
- Light from 09:00p.m to 09:00 a.m.

The immediate effect of this control action is the reducing area power losses from 4.7 to 3.6 MW. These values result in energy conservation of approximately 23.4 % or 9.2 MWh, during the time of analysis (24 hours). Considering the spot price of Brazilian Interconnected System for September of 2001 (US\$268.24 – heavy, medium and light loading) result in a daily profit of US\$ 2.467,76 or a mensal profit of US\$74.032,94. The results present above demonstrate the effectiveness of CSVC in economics and operational terms.

### 5.3 Dynamic Analysis

In order to assess the dynamic behaviour of CSVC the following events are performed: incremental load increasing and decreasing, transmission line outage and feeder outage. The results for these events are presented as follow:

- *Incremental Load Increasing*

This event represents an incremental load increasing about 128% (from 184MW to 420MW) in all area. Figure 4 depicts voltage profile in Pilot Buses (FAR-69 – GAR-69) and shows ULTC tap positions for this situation. Voltage profile in load buses are showed in Figure 5.

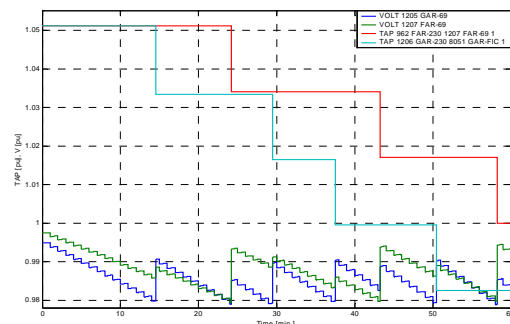

Figure 4: Voltage Profile in Pilot Buses and ULTC Tap position - Incremental Load Curves

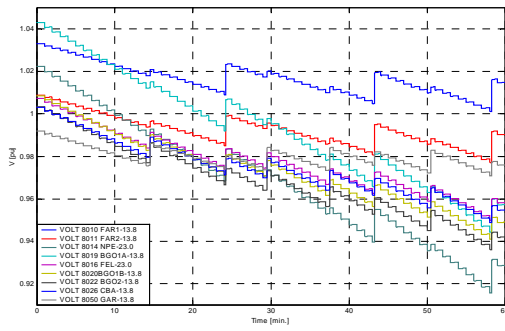

Figure 5: Voltage Profile in Load Buses - Incremental Load Curves

It can be observed in Figures 4 and 5 that ULTC tap coordination of CSVC scheme keep the voltage profile, of pilot and load buses, inside the security range and operationally stable. The ULTC action time of control buses are synchronized to reach a position determined for CSVC.

- *Incremental load decreasing*

Figures 6 and 7 show voltage profiles in pilot and load buses, respectively, and ULTC tap position, when is applied an incremental load decreasing about 11.9% (from 420MW to 370MW) in all system.

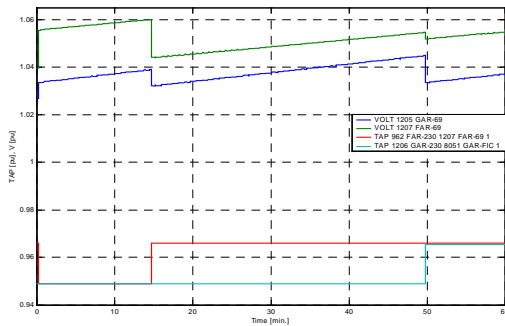

Figure 6: Voltage Profile in Pilot Buses and ULTC Tap position - Incremental Load Curves

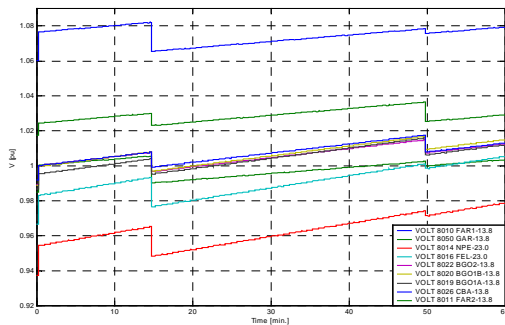

Figure 7: Voltage Profile in Load Buses - Incremental Load Curves

When occur a transition between heavy and light loading, showed in Figures 6 and 7, tap positions are coordinated to assure that voltage profiles (pilot and load buses) have optimized values and are inside a stable and security operation range ( $0.95pu < V_{bus} < 1.05pu$ ).

- *Transmission Line Outage*

Figures 8 and 9 present the simulation results, for a medium loading (420MW), when is considered an outage of a transmission line called FAR-230kV – GAR-230kV. The performance of voltage profile in pilot and load buses are analysed.

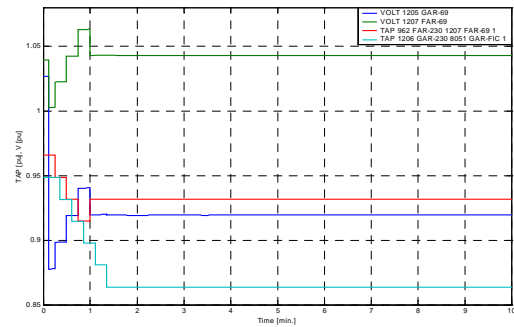

Figure 8: Pilot Buses Voltage Profile – Outage of transmission line (FAR-230kV – GAR-230kV)

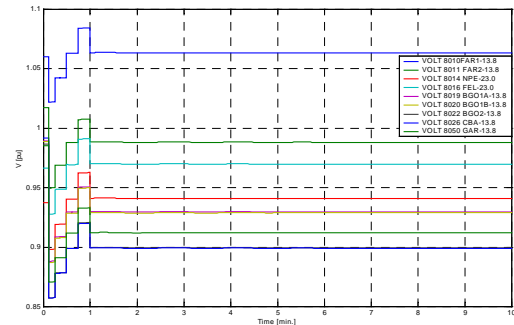

Figure 9: Load Buses Voltage Profile - Outage of transmission line (FAR-230kV – GAR-230kV)

When occur a line transmission outage it can be observed by Figures 8 and 9, that action on tap position get the load voltages, after the tap changing, for safe values in steady state, showing the feasibility of CSVC for emergency conditions.

- *Feeders Outage*

This events describe a feeder outage at BGO2-13 bus, which has a load of 40.2MW+j18.4MVAR. Figures 10 and 11 depicts voltage profile in pilot and load buses, respectively, and ULTC tap position.



Figure 10: Pilot Voltage Profile - Load Outage (BGO2-13)

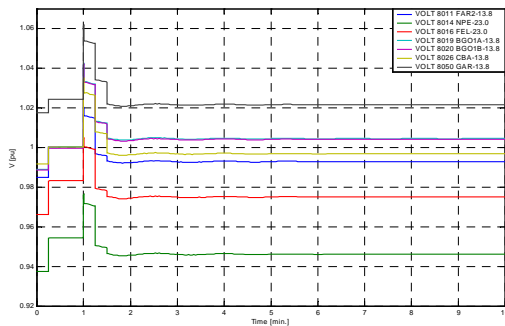

Figure 11: Load Buses Voltage Profile - Load Outage (BGO2-13)

When occur feeders outage (or substation outage) the tap position changing coordinated to guarantee voltage security levels (Figure 10). However, due to critical event there are some oscillations in pilot and load buses (Figures 10 and 11), but these voltages stabilize in steady state.

## 6 CONCLUSIONS

This paper has presented an dynamic analysis of a voltage control called coordinated secondary voltage control (CSVC). This analysis is focused on Under Load Tap Changing (ULTC) coordination and their effects on voltage profiles, power losses and reactive flow.

Normal operations conditions considering transitions between three loading level, from light to medium and from medium to heavy, with increasing and decreasing incremental demand, respectively, are investigated. The results shows a good performance of ULTC coordination scheme. It can be observed that voltage profiles and tap position keep stable inside the security range. The frequency of tap changes are less frequent than the traditional operation mode.

The coordination of ULTC used to control action in CSVC scheme have proven to be flexible and safe for normal and emergency conditions. Additional researches are being developed to obtain an automatic methodology for ULTC coordination.

## REFERENCES

- [1] W. R. Cassel, "Distribution Management Systems: Functions and Payback", IEEE Transactions on Power Systems, Vol.8, N<sup>o</sup>.3, pp 796-801, Aug 1993.
- [2] S. Corsi, V. Arcidiacono, M. Cambi and L. Salvaderi, "Impact of Restructuring Process at ENEL on The Network Voltage Control Service", Proceedings of IV Bulk Power System Dynamics and Control – Restructuring , pp. 407-416, August 24-28, 1998, Santorini, Greece.
- [3] N. S. Markushevich, "Voltage and Var Control in Automated Distribution System", Third International Symposium of Distribution Automation and Demand Side Management, FL, USA, pp. 478-485.
- [4] J.P.Paul, J.Y.Léost, J.M.Tesson, "Survey of the Secondary Voltage Control in France: Present Realization and Investigations", IEEE Transactions on Power Systems, Vol. 2, pp. 505-511, May 1987.
- [5] H.Vu, P.Pruvot, C.Launnay, Y.Harmand, "An Improved Voltage Control on Large-Scale Power System", IEEE Transactions on Power Systems, Vol.11, N<sup>o</sup>. 3, pp 1295-1303, Aug 1996.
- [6] S.Corsi, P.Marannino, N. Losignore, G.Moreschini, G.Piccini, "Coordination between the Reactive Power Scheduling Function and the Hierarchical Voltage Control of the EHV ENEL System", IEEE Transactions on Power Systems, Vol.10, N<sup>o</sup>.2, pp 686-694, May 1995.
- [7] S. Corsi, "The Secondary Voltage Regulation in Italy", Panel Session on Power Plant Secondary Voltage Control, IEEE/PES Summer Meeting, Seattle, WA, July 2000.
- [8] J. Van Hecke, N. Janssens, J. Deuse and F. Promel, "Coordinated Voltage Control Experience in Belgium", CIGRE, 38-111, Paris, August 2000.
- [9] J. L. Sancha, J. L. Fernandez, A. Cortes, J. T. Abarca, "Secondary voltage Control: Analysis, solutions and Simulation Results for The Spanish Transmission System", IEEE Trans. On Power System, Vol.11, N<sup>o</sup> 2, May 1996.
- [10] G. Taranto, N. Martins, A.C.B. Martins, D.M.Falcão, M.G. dos Santos, "Benefits of Applying Secondary Voltage Control Schemes to The Brazilian System", IEEE/PES Summer Meeting, Seattle, WA, July 2000.
- [11] I. Roytelman and V. Ganesan, "Coordinate Local and Centralized Control in Distribution Management Systems", IEEE Trans on Power Delivery, Vol. 15, N<sup>o</sup> 2, pp. 718-724, April 2000.
- [12] L. Roytelmen, S. M. Shahidehpour, "Practical Aspects of Distribution Automation in Normal and Emergency Conditions", IEEE Trans. On Power Delivery, Vol.8, N<sup>o</sup> 4, pp. 2002-2008, 1993.

- [13] V. Miranda, M. Matos, J. P. Lopes, J. T. Saraiva, J. N. Fidalgo, M. T. Ponce de Leão, "Intelligent Tools in a Real-World DMS Environment", IEEE Power Engineering Society Summer Meeting, Vol. 1, pp. 163-168, 2000.
- [14] M. P. Silva, J. T. Saraiva, A. V. Souza, "A Web Browser based DMS-Distribution Management System", IEEE Power Engineering Society Summer Meeting, Vol. 4, pp. 2338-2343, 2000.
- [15] L. Roystelmen, B.K. Wee and R.-L. Lugtu, "Volt/Var Control Algorithm for Modern Distribution Management System", IEEE Trans. on Power System, Vol.10, N<sup>o</sup> 3, pp.1454-1460, 1995.
- [16] J.C. Wang, H.D. Chiang, K. N. Mil and G. D. Darling, "Capacitor Placement and Real Time Tune Control in Large-Scale Unbalance Distribution System: Loss reduction Formula, Problem Formulation, Solution Methodology and Mathematical Justification", IEEE Trans on Power Delivery, Vol. 12, N<sup>o</sup> 2, pp. 953-958, 1997.
- [17] I. Roystelman, B. K. Wee, R. L. Lugtu, T.M. Kulas and T. Brossart, "Pilot Project to Estimate the Centralized Volt/Var Control Effectiveness", IEEE Trans. on Power System, Vol.13, N<sup>o</sup> 3, pp. 864-869, August 1998.
- [18] L.H.Fink, P.J.M.Van Son, "On System Control Within a Restructured Industry", IEEE Transactions on Power Systems, Vol.13, N<sup>o</sup>. 2, pp 611-616, May 1998.
- [19] H. Lefebvre, D. Fragnier, J. Boussion, P. Mallet, M. Bultot, "Advantages of Coordinated Secondary Voltage Control in Deregulated Environment", CIGRE, 39-208, Paris, August 2000.
- [20] F. A. B. Lemos, L. C. Werberich, J. S. Freitas, M. A. Rosa, "A New Approach of Coordinated Secondary Voltage Control Applied in Transmission and Sub-Transmission Level". Proceedings of 22<sup>nd</sup> IEEE-PICA, pp. 223-229, VOL. I, Sidney - Austrália, May 2001.
- [21] F. A. B. Lemos, L. C. Werberich, J. S. Freitas, M. A. Rosa, "A Strategic for Voltage Coordinated Control to Improve System Operation". Proceedings of IEEE POWER TECH, Porto - Portugal, pp. 363, Vol. 2, September 2001.
- [22] W. L. Feijó Jr., F. A. B. Lemos, Haffner S., L. C. Werberich, M. A. Rosa, "A Methodology to Support Coordinated Secondary Voltage Actions", will be presented in VIII Symposium of Specialists in Electric Operational and Expansion Planning – SEPOPE, Brasília – DF, Brazil, May 2002.
- [23] Calovic, M. S., "Modeling and Analysis of Under-Load Tap-Changing transformer Control Systems", IEEE Trans. On Power Apparatus and Systems, Vol. PAS-103, N<sup>o</sup>. 7, July 1984.

**Flávio Antônio Becon Lemos** received his degree in Electrical Engineering from Universidade Federal de Santa Maria, Brazil in 1988, and the M.Sc. and Ph.D. degree in Electrical Engineering from Universidade Federal de Santa Catarina in 1994 and 2000, respectively. During 96/97 he was a research fellow at Brunel University, UK. He was employed by State Electrical Utility in Porto Alegre, RS from 1988 to 1992. Since 1990, he has been with Pontifícia Universidade Católica do Rio Grande do Sul, Porto Alegre, Brazil. He is the head of Electrical Energy System Group (GSEE). His main research interests are in the area of power systems dynamics, voltage stability, voltage control and non-linear systems. He is member of CIGRE Task Force of Secondary Voltage Control.

**Wilson Lacerda Feijó Júnior** received his degree in electrical Engineering from Pontifícia Universidade Católica do Rio Grande do Sul, Porto Alegre, Brazil in 1997. He was employed by RGE from 1998 to 2000. His areas of expertise include voltage control, planning and operation of distribution systems. He is currently a M.Sc. student at Pontifícia University Catholic of Rio Grande do Sul, Porto Alegre, Brazil.

**Luis Carlos Werberich** received his degree in Electrical Engineering from Universidade Federal de Santa Maria, Brazil in 1978. He has over 20 years of experience in electrical utilities where he is a senior engineering of power system analysis. His areas of expertise include power system control and protection, system dynamic performance and power system planning.

**Mauro Augusto da Rosa** received his degree in Electrical Engineering from Pontifícia Universidade Católica do Rio Grande do Sul, Porto Alegre, Brazil in 1998. He joined in RGE in 1998. His areas of expertise at RGE include planning and operation of distribution systems. He is currently a M.Sc. student at Pontifícia University Catholic of Rio Grande do Sul, Porto Alegre, Brazil.